



MULTIFIT TYPE



SAE STANDARD CONNECTIONS

DIN STANDARD CONNECTIONS

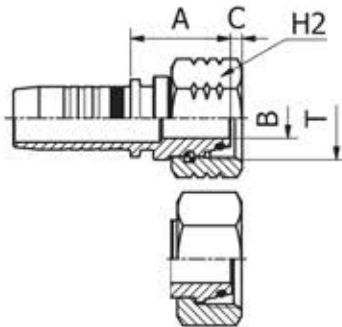

M21512/M21513

METRIC O-RING FEMALE
24° CONE LIGHT DUTY
DIN 20066 / ISO 12151-2

PART. REF.	HOSE BORE			Thread	Pipe	DIMENSIONS mm						
	DN	Dash	inch			T	B	A	C			
M21512-04-12	6	- 4	1/4"	M 12X1.5	6.0	3.0	21.0	2.2	17.0			
M21512-05-14	8	- 5	5/16"	M 14X1.5	8.0	4.0	20.0	2.9	17.0			
M21512-06-16	10	- 6	3/8"	M 16X1.5	10.0	6.0	23.0	3.0	19.0			
M21512-08-18	12	- 8	1/2"	M 18X1.5	12.0	7.0	29.0	2.9	22.0			
M21512-10-18	16	- 10	5/8"	M 18X1.5	12.0	7.0	29.0	2.9	22.0			
M21512-10-22	16	- 10	5/8"	M 22X1.5	15.0	9.5	26.5	2.4	27.0			
M21512-12-22	19	- 12	3/4"	M 22X1.5	15.0	9.5	31.0	2.4	27.0			
M21512-12-26	19	- 12	3/4"	M 26X1.5	18.0	12.5	31.0	2.3	32.0			
M21512-16-30	25	- 16	1"	M 30X2	22.0	15.0	34.0	4.2	36.0			
M21512-20-36	31	- 20	1.1/4"	M 36X2	28.0	19.8	35.5	5.0	41.0			
M21512-24-45	38	- 24	1.1/2"	M 45X2	35.0	26.0	42.5	5.8	50.0			
M21512-32-52	51	- 32	2"	M 52X2	42.0	32.0	50.5	5.6	60.0			
M21513-03-12	5	- 3	3/16"	M 12X1.5	6.0	3.0	22.0	0.7	14.0			
M21513-03-14	5	- 3	3/16"	M 14X1.5	8.0	4.0	24.5	1.3	17.0			
M21513-04-14	6	- 4	1/4"	M 14X1.5	8.0	4.0	22.0	1.3	17.0			
M21513-04-16	6	- 4	1/4"	M 16X1.5	10.0	6.0	22.5	1.8	19.0			
M21513-04-18	6	- 4	1/4"	M 18X1.5	12.0	7.0	22.0	2.0	22.0			
M21513-05-16	8	- 5	5/16"	M 16X1.5	10.0	6.0	22.5	1.8	19.0			
M21513-05-18	8	- 5	5/16"	M 18X1.5	12.0	7.0	22.0	2.0	22.0			
M21513-06-18	10	- 6	3/8"	M 18X1.5	12.0	7.0	22.5	2.0	22.0			
M21513-06-22	10	- 6	3/8"	M 22X1.5	15.0	9.3	25.0	1.5	27.0			
M21513-08-22	12	- 8	1/2"	M 22X1.5	15.0	9.3	25.5	1.5	27.0			
M21513-08-26	12	- 8	1/2"	M 26X1.5	18.0	12.5	26.0	2.0	32.0			
M21513-10-26	16	- 10	5/8"	M 26X1.5	18.0	12.5	26.0	2.0	32.0			
M21513-10-30	16	- 10	5/8"	M 30X2	22.0	15.0	34.0	3.0	36.0			
M21513-10-36	16	- 10	5/8"	M 36X2	28.0	20.0	30.5	3.7	41.0			
M21513-12-30	19	- 12	3/4"	M 30X2	22.0	15.0	28.0	3.0	36.0			
M21513-12-36	19	- 12	3/4"	M 36X2	28.0	20.0	28.5	3.7	41.0			
M21513-16-36	25	- 16	1"	M 36X2	28.0	19.8	29.5	3.7	41.0			
M21513-16-45	25	- 16	1"	M 45X2	35.0	26.0	39.0	4.0	50.0			
M21513-20-45	31	- 20	1.1/4"	M 45X2	35.0	26.0	33.0	4.0	50.0			
M21513-20-52	31	- 20	1.1/4"	M 52X2	42.0	32.0	32.5	4.5	60.0			
M21513-24-52	38	- 24	1.1/2"	M 52X2	42.0	32.0	33.0	4.5	60.0			