

Assembly Instructions for O-Ring Port Straight Stud Ends

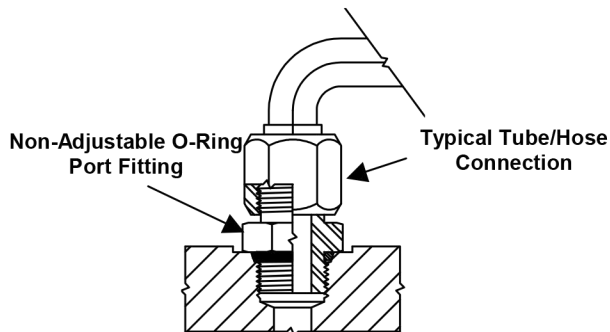

Fig. A5 Typical Straight Stud End O-Ring Port Installation

1. Inspect components for damage or contamination.
2. Lubricate O-ring and threads with light oil or system fluid, install O-ring in groove on the fitting.
3. Screw stud into the O-ring port and tighten to recommended torque listed in Table A4 or A5.

Table A4. Assembly Torque, SAE J1926-3 Light Duty Stud Ends (Ref. SAE J514 Tube Fittings and Port Plugs)¹

Tube Size	Thread Size	Ft. Lbs.	Nm.
-2	5/16-24	6-7	8-9
-3	3/8-24	8-9	11-12
-4	7/16-20	13-15	18-20
-5	1/2-20	17-19	23-26
-6	9/16-18	22-24	29-33
-8	3/4-16	40-43	49-53
-10	7/8-14	43-48	59-64
-12	1-1/16-12	68-75	93-102
-14	1-3/16-12	90-99	122-134
-16	1-5/16-12	112-123	151-166
-20	1-5/8-12	146-161	198-218
-24	1-7/8-12	154-170	209-231
-32	2-1/2-12	218-240	296-325

1) Lubricated assembly

Table A5. Assembly Torque, SAE J1926-2 Heavy Duty Stud Ends (Ref. SAE J1453 ORFS Fittings)¹

Tube Size	Thread Size	Ft. Lbs.	Nm.
-3	3/8-24	8-10	11-13
-4	7/16-20	14-16	20-22
-5	1/2-20	18-20	24-27
-6	9/16-18	24-26	33-35
-8	3/4-16	50-60	68-78
-10	7/8-14	72-80	98-110
-12	1-1/16-12	125-135	170-183
-14	1-3/16-12	170-190	230-260
-16	1-5/16-12	200-220	270-300
-20	1-5/8-12	210-280	285-380
-24	1-7/8-12	270-360	370-490

1) Lubricated assembly

