

## Blanking screws

For threaded holes according to DIN 3852 / ISO 1179

Thread: Whitworth pipe thread, parallel

Sealing with PEFLEX profile seal ring

Standard profile seal ring material is NBR

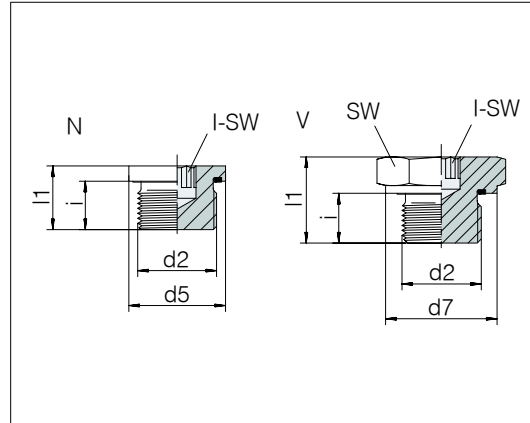

d2	Pressure	d5	d7	l1	SW	I-SW	i	Form	Nm -10 %	kg/100 ca.	Order designation
G 1/8 A	PN 400	14		12.3		5	8	N	12	0.7	GP-PLIH-G1/8E-C21
G 1/4 A	PN 400	18.9		17.3		6	12	N	25	1.8	GP-PLIH-G1/4E-C21
G 3/8 A	PN 400	22		17.3		8	12	N	50	2.7	GP-PLIH-G3/8E-C21
G 1/2 A	PN 400	26.9		19.3		10	14	N	70	4.4	GP-PLIH-G1/2E-C21
G 3/4 A	PN 400	32		21.3		12	16	N	120	7.5	GP-PLIH-G3/4E-C21
G 1 A	PN 400	39.9		22.8		17	16	N	200	12.3	GP-PLIH-G1E-C21
G 1 A	PN 400		46	33	46	17	18	V	250	27.2	GP-PLIH-G1E-C21
G 1 1/4 A	PN 400		57	38	60	22	20	V	400	54.3	GP-PLIH-G11/4E-C21
G 1 1/4 A	PN 315		49.9		22.8	22	16	N	320	19.4	GP-PLIH-G11/4E-C21
G 1 1/2 A	PN 400		64	40	65	24	22	V	500	69.3	GP-PLIH-G11/2E-C21
G 1 1/2 A	PN 315		55		22.8	24	16	N	400	25.2	GP-PLIH-G11/2E-C21

Example for comp. :  
VST11/8ED

Threaded holes as spec. in  
DIN 3852, form X.  
d5 = d4 narrow