

ES-4 / ES-4VA cutting rings

Standard material of moulded seals and O-rings is FPM/FKM

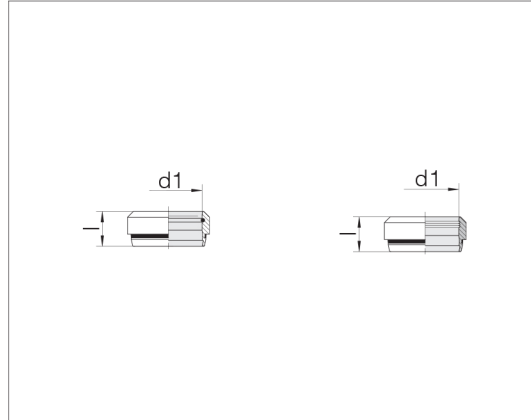

Series Tube OD d1	Pressure	l	Order designation steel	Order designation stainless steel
L/S 6	PN 500/800	8.8	24-ES4-L/S6	24-ES4-L/S6-SST
L/S 8	PN 500/800	8.8	24-ES4-L/S8	24-ES4-L/S8-SST
L/S 10	PN 500/800	9.8	24-ES4-L/S10	24-ES4-L/S10-SST
L/S 12	PN 400/630	9.8	24-ES4-L/S12	24-ES4-L/S12-SST
L 15	PN 400	10.2	24-ES4-L15	24-ES4-L15-SST
L 18	PN 400	10.2	24-ES4-L18	24-ES4-L18-SST
L 22	PN 250	11.5	24-ES4-L22	24-ES4-L22-SST
L 28	PN 250	11.5	24-ES4-L28	24-ES4-L28-SST
L 35	PN 250	13.5	24-ES4-L35	24-ES4-L35-SST
L 42	PN 250	13.5	24-ES4-L42	24-ES4-L42-SST
S 14	PN 630	10.2	24-ES4-S14	24-ES4-S14-SST
S 16	PN 630	10.2	24-ES4-S16	24-ES4-S16-SST
S 20	PN 420	12.5	24-ES4-S20	24-ES4-S20-SST
S 25	PN 420	12.5	24-ES4-S25	24-ES4-S25-SST
S 30	PN 420	13.5	24-ES4-S30	24-ES4-S30-SST
S 38	PN 420	13.5	24-ES4-S38	24-ES4-S38-SST

Cutting-rings for tube OD
6 - 12 mm are identical for
series L + S .

Example for comp. :
ISO 8434-1-CR-L6-St

