



CARBON STEEL HYDRAULIC FITTINGS

J.I.C. – S.A.E. J514

STANDARD – JUMPSIZE – SPECIAL



AIR-WAY
GLOBAL MANUFACTURING

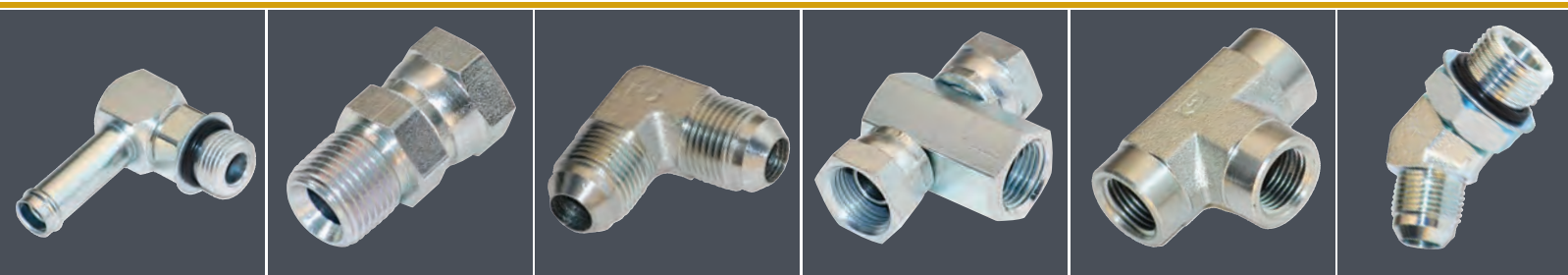

Please see our additional product lines and on-line catalog at AIR-WAY.com

BULLETIN #405 | 2014



O-RING FACE SEAL FITTINGS

SAE J1453 ISO 8434-3
FEATURING SAE J1353 STYLE B, DOVETAIL GROOVE



AIR-WAY
GLOBAL MANUFACTURING



O-RING FACE SEAL FITTINGS

provide connections between tubing, Male or Female NPTF pipe and SAE J1926/1/ISO1926-1 O-Ring ports.

The ORFS tube end features the SAE-J1453 Style B Dovetail Groove for improved O-Ring retention. Many ORFS fittings are also available in stainless steel.

BULLETIN #205 | 2014



FLARE-O® HYDRAULIC FITTINGS

J.I.C. - S.A.E.
STANDARD - JUMPSIZE - SPECIAL



AIR-WAY
GLOBAL MANUFACTURING



**FLARE-O®
HYDRAULIC FITTINGS**

offer an electromeric seal for leakproof, drop-in replacement for 37° SAE/JIC flared tube fittings. This bulletin includes carbon steel 37° FLARE-O® tube fittings, Male and Female NPTF pipe, adjustable and O-Ring fittings, adapter unions, braze fittings for tubing and beaded hose connections. All FLARE-O® fittings are also offered in stainless steel.

BULLETIN #505 | 2014



PATRIOT BRASS HYDRAULIC FITTINGS



AIR-WAY
GLOBAL MANUFACTURING



**PATRIOT BRASS
HYDRAULIC FITTINGS**

include 37° Flare Tube, Pipe, Hose Barb and Push-Lok styles. All shaped Brass elbows and Tees are manufactured with the Forged style construction.



AIR-WAY
GLOBAL MANUFACTURING

AIR-WAY GLOBAL MANUFACTURING COMPANY | *ADAPT TO ANYTHING*

Table Of Contents

Section 1. Technical Data

	PAGE
Fitting Product Data and Pressure Ratings	
Fitting Product Data	5
Hydraulic Tube Fittings, Pressure Ratings	6
ORFS Tube Fittings, Pressure Ratings	7
Assembly Instructions	
37 Degree Tube Fittings and Adapters	8
O-Ring Port Non-Adjustable Stud Ends	9
Adjustable Stud End O-Ring Port Fittings	10
NPTF and BSPT Pipe Threads	12
Adapter Unions/Female NPSM Pipe Swivel Ends	13
Code 61 and Code 62 Four Screw Split Flange Connections	14
Beaded Hose Stem Connections	15
Silver Brazed Tube Connections	16
Flares for Tubing	17
ORFS Fittings and Adapters	18
60° Cone Connectors	19
Hose and Tube Routing	20
Tubing Pressure Ratings	23
Fluid Compatibility	24

Section 2. Product Data

37 Degree Tube Fittings	
Features, 37 Degree Tube Fittings	27
37 Degree Tube Fittings Visual Index	29
Product Tables	
37 Degree Tube Fittings	
0302 Short Nut	32
0304 Standard Nut	32
0304-C Cap Nut	33
0306 Bulkhead Lock Nut	34
0306-N Adjustable Lock Nut	35
0318 Tube Nut	36
0319 Tube Sleeve	37
2403 Male Tube Union	38
2403-LH Large Hex Union	39
2404 Male Connector	40
2404-L Male Long Connector	42
2404-LL Male Extra Long Connector	42
2404-LLL Male Extra Extra Long Connector	43
2405 Female Connector	44
2406 Reducing Adapter (One Piece)	45
2407 Reducing Adapter	47
2408 Male Tube Plug	47
2500 90 Degree Union Elbow	48
2501 90 Degree Male Elbow	49
2501-L 90 Degree Male Long Elbow	52
2501-LL 90 Degree Male Extra Long Elbow	53
2501-LLL 90 Degree Male Extra Extra Long Elbow	54
2502 90 Degree Female Elbow	55
2503 45 Degree Male Elbow	57
2504 45 Degree Union Elbow	59
2505 45 Degree Female Elbow	59
2601 Male Branch Tee	60
2602 Female Branch Tee	62
2603 Union Tee	63
2605 Male Run Tee	67
2606 Female Run Tee	70
2607 Male Run/Branch Tee	70
2608 Female Run/Male Branch Tee	71

Table Of Contents

	PAGE
2609 Female Run/Branch Tee	71
2610 Male Run/Run Tee.....	72
2611 Male Run/Female Branch Tee	73
2612 Female Run/Run Tee	74
2613 Male Run/Female Run Tee.....	74
2650 Union Cross	75
2651 Male Branch Cross	77
2652 Female Branch Cross	78
2653 Male Branch/Branch Cross.....	78
2654 Male Run/Branch Cross	79
2658 Female Run/Branch/Branch Cross.....	79
2700-LN Bulkhead Union.....	80
2701-LN 90 Degree Bulkhead Elbow.....	81
2702-LN 45 Degree Bulkhead Elbow.....	82
2703-LN Bulkhead Branch Tee	83
2704-LN Bulkhead Run Tee	84
2705-LN Female Pipe/Bulkhead Connector	85
2706-LN Male Pipe/Bulkhead Connector	85
4305 Barbed Hose/Swivel Connector.....	86
6500 90 Degree Swivel Elbow.....	87
6500-L 90 Degree Long Swivel Elbow	89
6501 90 Degree Male Pipe/Swivel Elbow	90
6502 45 Degree Swivel Elbow.....	91
6503 90 Degree Female Pipe/Swivel Elbow.....	92
6504 Tube/Swivel Union	92
6505 Male Pipe/Swivel Connector.....	93
6506 Female Pipe/Swivel Connector.....	94
6507 45 Degree Female Pipe/Swivel Elbow.....	95
6509 Swivel/Female Straight Thread Connector	95
6565 Double Swivel Union.....	95
6600 Swivel Branch Tee.....	96
6602 Swivel Run Tee.....	98
6603 Swivel Run/Run Tee.....	102
6604 Male Pipe/Swivel Run/Run Tee.....	103
6605 Female Pipe/Swivel Run/Run Tee	103
6606 Swivel Tee.....	104
Adjustable and O-Ring Fittings	
Features, Adjustable and O-Ring Fittings	105
Adjustable and O-Ring Fittings Visual Index	107
Product Tables	
Adjustable and O-Ring Fittings	
4601 90 Degree Straight Thread Hose Fitting	109
4603 45 Degree Straight Thread Hose Fitting	111
4604 Male Straight Thread Hose Connector	112
4605 Male Straight Thread Run Hose Connector.....	113
4606 Male Straight Thread Branch Hose.....	113
6400 Straight Thread Connector	114
6400-L Straight Thread Connector Long.....	116
6401 Straight Thread/Male Pipe Adapter.....	117
6402 Straight Thread/Swivel Adapter	118
6403 Straight Thread Union.....	118
6404 O-Ring Port/Male Pipe Adapter	119
6405 Straight Thread/Female Pipe Adapter.....	120
6407 Straight Thread Adjustable Union	122
6408 Hexagon Head O-Ring Boss Plug	123
6409 Hexagon Socket O-Ring Boss Plug.....	124
6410 Straight Thread Reducer/Expander.....	125
6801 90 Degree Straight Thread Elbow.....	127

Table Of Contents

6801-L 90 Degree Straight Thread Elbow Long	130
	PAGE
6801-LL 90 Degree Straight Thread Elbow Extra Long	131
6801-LLL 90 Degree Straight Thread Elbow Extra Extra Long	132
6802 45 Degree Straight Thread Elbow	133
6803 Straight Thread Branch Tee	135
6804 Straight Thread Run Tee	139
6805 90 Degree Straight Thread/Female Pipe Elbow	144
6806 90 Degree Straight Thread/Male Pipe Elbow	145
6807 90 Degree Straight Thread Union Elbow	146
6808 45 Degree Straight Thread Union Elbow	146
6809 90 Degree Straight Thread/Swivel Elbow	147
6810 45 Degree Straight Thread/Swivel Elbow	147
6811 45 Degree Straight Thread/Female Pipe Elbow	148
4000 O-Rings for SAE J-1926/2/3 Inch Stud Ends	149
Braze Fittings For Tubing	
Features, Braze Fittings For Tubing	150
Braze Fittings For Tubing Visual Index	153
Product Tables	
Braze Fittings For Tubing	
0403 Braze Tube Union	154
403-L Braze Bulkhead Union	155
404 Male Pipe Union	155
405 Braze Female Pipe Union	156
500 Braze 90 Degree Tube Elbow	157
501 Braze 90 Degree Male Pipe Elbow	158
502 Braze 90 Degree Female Pipe Elbow	158
600 Braze Tube Run/Run Tee	159
601 Braze Male Pipe Run/Run Tee	159
602 Braze Female Pipe Run/Run Tee	160
603 Braze Junction Tee	160
701 Braze Tube Run Tee	161
702 Braze Tube Branch Tee	162
800 Braze Female Pipe Swivel Union	163
801 Braze 90 Degree Female Pipe Swivel Elbow	163
900 Braze 37 Degree Female Swivel Union	164
901 Braze 90 Degree-37 Degree Female Swivel	165
902 Braze 37 Degree Female Swivel Branch Tee	165
Braze Code 61 Flanged Head	166
Braze Code 62 Flanged Head	166
Adapter Unions	
Features, Adapter Unions	167
Adapter Unions Visual Index	169
Product Tables	
Adapter Unions	
1404 Female Adapter Union To Male Pipe	170
1405 Female Adapter Union To Female Pipe	171
1406 Female Adapter Union (Double Swivel)	171
1501 90 Degree Female Adapter Union To Male Pipe	172
1502 90 Degree Female Adapter Union To Female Pipe	174
1503 45 Degree Female Adapter Union To Male Pipe	175
1504 45 Degree Female Adapter Union To Female Pipe	177
1601 Female Adapter Union To Male Pipe Branch	178
1602 Female Adapter Union To Female Pipe Branch	179
1603 Female Adapter Union (Triple Swivel)	180
1604 Female Adapter Union Male Pipe Run Cross	181
1605 Female Adapter Union Cross (Quad Swivel)	181
6900 Female Adapter Union To Male Straight	182
6901 90 Degree Female Adapter Union To Adj. Male	183
6902 45 Degree Female Adapter Union To Adj. Male	184

Table Of Contents

	PAGE
NPTF Pipe Fittings	
Features, NPTF Pipe Fittings.....	185
NPTF Pipe Fittings Visual Index	186
Product Tables	
Pipe Fittings	
3051 90 Degree Short Street Elbow	187
4404 Male Pipe Thread Hose Connector	188
4501 90 Degree Male Pipe Hose Fitting.....	189
4503 45 Degree Male Pipe Hose Fitting.....	190
4504 Beaded Hose Fitting Tee.....	191
4505 Male Pipe Run Hose Fitting Tee.....	192
4506 Male Pipe Branch Hose Fitting Tee	192
5000 Hexagon Pipe Coupling	193
5404 Hexagon Pipe Nipple	194
5404-N Straight Pipe Nipple.....	195
5405 Pipe Adapter	196
5406 Pipe Reducer Bushing	197
5406-C Heavy Duty Female Pipe Cap Nut.....	198
5406-P Male Pipe Plug.....	198
5500 90 Degree Male Pipe Elbow	199
5501 45 Degree Male Pipe Elbow	200
5502 90 Degree Street Elbow.....	201
5503 45 Degree Street Elbow.....	203
5504 90 Degree Female Pipe Elbow	204
5505 45 Degree Female Pipe Elbow	205
5600 Male Pipe Tee.....	205
5601 Female Branch Pipe Tee	206
5602 Male Run Pipe Tee.....	207
5603 Female Run Pipe Tee	208
5604 Male Branch Pipe Tee	209
5605 Female Pipe Tee	210
5651 Female Branch Pipe Cross	212
5652 Female Pipe Cross	212
5653 Female Branch/Branch Pipe Cross	213
5654 Female Run/Branch Pipe Cross	213
5655 Male Run Pipe Cross.....	214
Long Allen Plugs.....	215
Four Bolt Flange Adapters	
Features, Four Bolt Flange Adapters	216
Four Bolt Flange Adapters Visual Index	219
Product Tables	
Four Bolt Flange Adapters	
1700-61 Code 61 Flange Adapter	220
1701-61 90 Degree Code 61 Bent Tube Flange Adapter Elbow.....	221
1703-61 45 Degree Code 61 Flange Adapter Elbow	222
1704-61 90 Degree Code 61 Flange Adapter Elbow	222
Code 61 Split Flange Clamp 223	
Code 62 Split Flange Clamp.....	223
JIC/ORFS Conversion Fittings	
Features, JIC/ORFS Conversion Fittings	224
JIC/ORFS Conversion Fittings Visual Index	227
Product Tables	
JIC/ORFS Conversion Fittings	
FF7403 Male ORFS Adapter/37 Degree Male JIC.....	228
FF7504 37 Degree Male JIC/Female ORFS Swivel Adapter.....	228
FF4000 O-Rings for SAE J-1453/2/3 Face Seal Ends.....	229
4000 O-Rings for SAE J-1926/2/3 Inch Stud Ends.....	230
FF9000 ORFS Braze Rings.....	231

Fitting Product Data

Construction

Unless otherwise specified, fittings are machined from cold drawn carbon steel barstock and forgings. Standard plating is electrodeposited zinc with a clear trivalent chromate conversion coating in accordance with ASTM B633 (Type V SC2). The minimum salt spray resistance is 240 hours to red corrosion when tested in accordance with ASTM B117.

Threads

BSPP Straight Threads: Internal and external BSPP straight threads conform to ISO 228-1.

Metric Straight Threads: Internal and external metric straight threads conform to ISO 261.

Inch Straight Threads: Internal and external inch straight threads conform to the Unified National Class 2A and Class 2B Series respectively, with modified minor diameters where specified. Plated external threads may conform to Class 3A maximum diameters after plating.

NPTF Threads: Male and female pipe threads conform to the Dryseal American Standard Taper Pipe Thread (SAE J476a, NPTF) Series which will provide pressure tight joints without the use of a lubricant or sealer. Use of these fittings with non-dryseal NPT pipe or hose ends is not recommended for high-pressure applications.

Note: Where not functionally objectionable, use of a compatible lubricant/sealant is recommended for either NPT or NPTF threads to minimize the possibility of galling in assembly.

BSPT Threads: Internal and external BSPT taper threads conform to BS 21 and BS EN 10226-1.

Assembly Information

For assembly instructions, refer to the Technical Data Section for the appropriate fitting end. Also, refer to the Technical Data Section for recommendations regarding tubing pressure ratings, tube flares and hose/tube routing information. Please note the following:

Tubing for single flare tube ends should be either seamless or welded and drawn, fully annealed tubing per SAE J524 or J525. For double flaring, tubing per SAE J356, J524, J525 or J526 may be used.

For proper sealing with 37 degree flared fittings, flares for tubing should conform to the requirements of SAE J533. For heavy wall tubing, the optional tube preparation and single flare configuration specified in SAE J533 is also recommended. This optional configuration provides extended sealing surface contact area versus conventional flares.

In the design and fabrication of tubing or hose runs for any hydraulic system, precautions should be taken to allow for sufficient adjustment of the hose or tubing so that proper alignment can be attained at the fitting connections. Improper fit-up or misalignment should be corrected before final connections are made. Location of fitting connections should be planned to maximize accessibility. Whenever possible, use a torque wrench to tighten connections to the recommended installation torque.

Ordering Information

For fittings with ISO 9974 metric O-Ring/Retaining Ring stud ends, the Retaining Ring may be removed to make the stud end compatible with an SAE J2244-1 or ISO 6149-1 port.

For fittings with ISO 1179-3 BSPP O-Ring/Retaining Ring stud ends, removing the Retaining Ring for use in a JIS B 2351-1 port is not recommended.

If information is needed for jump sizes not shown, please contact customer service for assistance. Dimensions are rounded for brevity. Please contact factory for exact dimensions and tolerances.

Hydraulic Tube Fittings, Pressure Ratings

The information contained in this catalog is subject to change without notice. The most current information can be found on the Air-Way web site – www.air-way.com.

The hydraulic tube fittings represented in this catalog conform to the performance requirements specified in SAE J514, SAE J518, SAE J1453, SAE J1926/ISO 11926 and related standards.

The working pressure ratings listed below are based on a 4:1 design factor for minimum burst. As specified in SAE J514, these are dynamic pressure ratings and the fittings are capable of passing a cyclic endurance (impulse) test for one million cycles at 133% of the corresponding working pressure.

The rated working pressure for any fitting is based on the

lowest pressure rated fitting end. For example, a fitting may include one -4 (1/4") male 37 degree tube end and one -6 (3/8") male pipe end. From the tables below, the rated working pressure for the -4 male 37 degree tube end is 34.5 MPa (5,000 psi) and the rated working pressure of the -6 (3/8") male pipe end is 21 MPa (3,000 psi). The rated working pressure of the fitting would be 21 MPa (3,000 psi).

For proper performance, the design of any hydraulic system should take into consideration the rated working pressures for each of the components of the system, including standard ratings for hose and tubing components and assemblies. For any application, sufficient testing should be performed to assure safe and satisfactory performance.

Pressure Ratings for 37 Deg. Flared Tube Ends, 37 Deg. Female Swivels, O-Ring Port Plugs and Straight Thread Stud Ends (Inch)										
Nominal Tube Size		Thread Size (Notes 1&2)	Working Pressures							
Nom SAE Dash Size	Nom Inch Tube O.D.	SAE J514 Flared Tube End and SAE J1926/3/ISO 11926-3 O-Ring Port Thread Size	37 Deg. Flared Tube Ends, Unions and Bulkheads		37 Deg. Female Swivels		SAE J514 (Inch) Port Plugs and Stud Ends Per SAE J1926/3/ISO 11926-3			
			MPa	psi	MPa	psi	Port Plugs/Non-Adjustable Studs		Adjustable Studs	
			MPa	psi	MPa	psi	MPa	psi	MPa	psi
-02	1/8	5/16-24 UNF	34.5	5,000	34.5	5,000	34.5	5,000	34.5	5,000
-03	3/16	3/8-24 UNF	34.5	5,000	34.5	5,000	34.5	5,000	34.5	5,000
-04	1/4	7/16-20 UNF	34.5	5,000	31	4,500	34.5	5,000	31.5	4,500
-05	5/16	1/2-20 UNF	34.5	5,000	27.5	4,000	34.5	5,000	27.5	4,000
-06	3/8	9/16-18 UNF	34.5	5,000	27.5	4,000	34.5	5,000	27.5	4,000
-08	1/2	3/4-16 UNF	31	4,500	27.5	4,000	31	4,500	27.5	4,000
-10	5/8	7/8-14 UNF	24	3,500	21	3,000	24	3,500	21	3,000
-12	3/4	1-1/16-12 UN	24	3,500	21	3,000	24	3,500	21	3,000
-14	7/8	1-3/16-12 UN	21	3,000	17	2,500	21	3,000	17	2,500
-16	1	1-5/16-12 UN	21	3,000	17	2,500	21	3,000	17	2,500
-20	1 1/4	1-5/8-12 UN	17	2,500	14	2,000	17	2,500	14	2,000
-24	1 1/2	1-7/8-12 UN	14	2,000	10.5	1,500	14	2,000	10.5	1,500
-32	2	2-1/2-12 UN	10.5	1,500	8	1,125	10.5	1,500	8	1,125

1) Threads per SAE J475 Class 2A ext. Class 2B int. (Ref. ISO-263/ISO-R725)

2) Unified class 2B threads apply to swivel nuts and with minor diameter modified to class 3B limits for locknuts

Pressure Ratings for Fittings With NPTF Pipe Threads and Adapter Unions							
Nominal Pipe Size		Thread Size		Working Pressures			
Nom SAE Dash Size	Nom Inch Pipe O.D.	Dryseal Pipe Thread (NPTF ¹) Male and Female	Straight Pipe Thread (NPSM ²) Female Swivels	Fittings With NPTF Pipe Threads		Adapter Unions	
				MPa	psi	MPa	psi
-02	1/8	1/8-27	1/8-27	34.5	5,000	34.5	5,000
-04	1/4	1/4-18	1/4-18	27.5	4,000	34.5	5,000
-06	3/8	3/8-18	3/8-18	21	3,000	27.6	4,000
-08	1/2	1/2-14	1/2-14	21	3,000	24.1	3,500
-12	3/4	3/4-14	3/4-14	17	2,500	15.5	2,250
-16	1	1-11-1/2	1-11-1/2	14	2,000	13.8	2,000
-20	1 1/4	1-1/4-11-1/2	1-1/4-11-1/2	8	1,150	11.2	1,625
-24	1 1/2	1-1/2-11-1/2	1-1/2-11-1/2	7	1,000	8.6	1,250
-32	2	2-11-1/2	2-11-1/2	7	1,000	7.8	1,125

1) Dryseal American Standard Taper Pipe Thread

2) American Standard Straight Pipe Thread for Mechanical Joints

Pressure Ratings for ORFS Male Tube Ends, Female Swivels and Straight Thread Stud Ends (Inch)									
Nominal Tube Size		Thread Size (Notes 1&2)		Working Pressures					
Nom SAE Dash Size	Nom Inch Tube O.D.	SAE J1453 ORFS Tube End	SAE J1926/2/ ISO 11926-2 O-Ring Port Thread Size	ORFS Tube Ends, Unions and Bulkheads		Heavy Duty Stud Ends Per SAE J1453, J1926/2/ISO 11926-2			
						Non-Adjustable Studs		Adjustable Studs	
				MPa	psi	MPa(3)	psi	MPa(3)	psi
-04	1/4	9/16-18 UNF	7/16-20 UNF	41.3	6,000	63	9,000	40	6,000
-05	5/16	5/8-18 UNF	1/2-20 UNF	41.3	6,000	63	9,000	40	6,000
-06	3/8	11/16-16 UNF	9/16-18 UNF	41.3	6,000	63	9,000	40	6,000
-08	1/2	13/16-16 UNF	3/4-16 UNF	41.3	6,000	63	9,000	40	6,000
-10	5/8	1-14 UNF	7/8-14 UNF	41.3	6,000	63	9,000	40	6,000
-12	3/4	1-3/16-12 UN	1-1/16-12 UN	41.3	6,000	40	6,000	40	6,000
-14	7/8	1-5/16-12 UN	1-3/16-12 UN	41.3	6,000	40	6,000	40	6,000
-16	1	1-7/16-12 UN	1-5/16-12 UN	41.3	6,000	40	6,000	31.5	5,000
-20	1 1/4	1-11/16-12 UN	1-5/8-12 UN	27.5	4,000	25	4,000	25	4,000
-24	1 1/2	2-12 UN	1-7/8-12 UN	27.5	4,000	25	4,000	20	3,000

- 1) Threads per SAE J475 Class 2A ext. Class 2B int. (Ref. ISO-263/ISO-R725)
- 2) Unified class 2B threads apply to swivel nuts and with minor diameter modified to class 3B limits for locknuts
- 3) MPa ratings for J1926/2/ISO 11926-2 stud ends are rationalized values as published in those standards.

Pressure Ratings for Code 61 Four-Screw Split Flange Ends								
Nominal Flange Size		Screw Dimensions			Working Pressures @ Recommended Torque (Note: See Below)			
Nom SAE Dash Size	Nom Inch Pipe O.D.	Thread	Length		Maximum Recommended Working Pressure		Recommended Torque Range	
			mm	inch	MPa	psi	Nm	lb-in
-08	1/2	5/16-18	32	1-1/4	34.5	5,000	20-25	175-225
-12	3/4	3/8-16	32	1-1/4	34.5	5,000	28-40	250-350
-16	1	3/8-16	32	1-1/4	34.5	5,000	37-48	325-425
-20	1 1/4	7/16-14	38	1-1/2	27.6	4,000	48-62	425-550
-24	1 1/2	1/2-13	38	1-1/2	20.7	3,000	62-79	550-700
-32	2	1/2-13	38	1-1/2	20.7	3,000	73-90	650-800
-40	2 1/2	1/2-13	44	1-3/4	17.2	2,500	107-124	950-1100
-48	3	5/8-11	44	1-3/4	13.8	2,000	186-203	1650-1800
-56	3 1/2	5/8-11	51	2	3.4	500	158-181	1400-1600
-64	4	5/8-11	51	2	3.4	500	158-181	1400-1600
-80	5	5/8-11	57	2-1/4	3.4	500	158-181	1400-1600

Table JP4. Pressure Ratings for Code 62 Four-Screw Split Flange Ends								
Nominal Flange Size		Screw Dimensions			Working Pressures @ Recommended Torque (Note: See Below)			
Nom SAE Dash Size	Nom Inch Pipe O.D.	Thread	Length		Maximum Recommended Working Pressure		Recommended Torque Range	
			mm	inch	MPa	psi	Nm	lb-in
-08	1/2	5/16-18	32	1-1/4	41.4	6,000	20-25	175-225
-12	3/4	3/8-16	38	1-1/2	41.4	6,000	34-45	300-400
-16	1	7/16-14	44	1-3/4	41.4	6,000	56-68	500-600
-20	1 1/4	1/2-13	44	1-3/4	41.4	6,000	85-102	750-900
-24	1 1/2	5/8-11	57	2-1/4	41.4	6,000	158-181	1400-1600
-32	2	3/4-10	70	2-3/4	41.4	6,000	271-294	2400-2600

Note: SAE J518, Code 61 and Code 62 Four-Screw Split Flange connections are non-threaded port ends which utilize O-Rings for sealing. They are assembled to ports with split flange clamp halves and clamping pressure is provided by screws or socket head cap

screws of SAE Grade 8 or ISO Class 10.9 material as specified in SAE J429 and ISO 898-1.

Flanged head ends are incorporated into fittings having suitable means for attachment to tubes, pipes or hoses to provide connection ends.

Assembly Instructions for 37 Degree Tube Fittings and Adapters

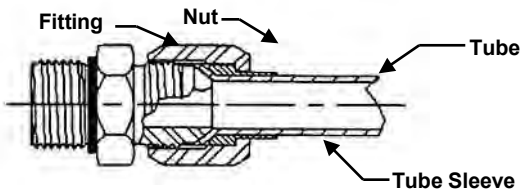

Fig.20 37° Tube Fitting Assembly

Method A. Installation Torque

1. Inspect components for damage or contamination.
2. If O-Ring (**FLARE-O® only**) is not present, install correct O-Ring in FLARE-O® groove, taking care not to cut or nick the O-Ring.
3. Lubricate the O-Ring with a light coat of system fluid or compatible oil.
4. Align tube/hose to mating fitting allowing hand connection. To assure proper alignment, two to three turns of nut should be easily permitted.
5. Tighten tube nut to torque listed in Table K.

Table K. Assembly Torque, 37° Tube Fittings					
Tube Size	Thread Size	37° Tube/ Swivel Nut		FLARE-O® Tube/ Swivel Nut	
		Ft. Lbs.	Nm.	Ft. Lbs.	Nm.
-02	5/16-24	6-7	8-9	-	-
-03	3/8-24	8-9	11-12	-	-
-04	7/16-20	11-12	15-16	7-8	9-11
-05	1/2-20	14-15	19-21	10-12	13-16
-06	9/16-18	18-20	24-28	14-16	19-22
-08	3/4-16	36-39	49-53	21-24	28-33
-10	7/8-14	57-63	77-85	28-32	38-43
-12	1 1/16-12	79-88	107-119	52-56	71-76
-14	1 3/16-12	94-103	127-140	60-64	81-87
-16	1 5/16-12	108-113	147-154	63-72	85-98
-20	1 5/8-12	127-133	172-181	84-96	114-130
-24	1 7/8-12	158-167	215-226	91-104	123-141
-32	2 1/2-12	245-258	332-350	210-240	285-325

Method B. Flats From Finger Tight (F.F.F.T.)

1. Inspect components for damage or contamination.
2. Align tube/hose to mating fitting allowing hand connection. To assure proper alignment, two to three turns of nut should be easily permitted.
3. Finger tighten or lightly wrench nut to seat sealing surfaces.
4. Mark nut and adjacent fitting surface to indicate initial seating position. See Fig.21.
5. Finish tightening nut by turning the appropriate F.F.F.T. as indicated in Table L.
6. Mark final tightening position on fitting by extending the existing mark from the nut to the adjacent fitting surface. See Fig.22.

Table L. Flats From Finger Tight Installation Method ¹					
Tube Size	Straight Thread Size	37° Tube Nut F.F.F.T.	FLARE-O® Tube Nut F.F.F.T.	Swivel Nut F.F.F.T.	FLARE-O® Swivel Nut F.F.F.T.
-02	5/16-24	---	---	---	---
-03	3/8-24	---	---	---	---
-04	7/16-20	2	2	1.5	1
-05	1/2-20	2	2	2	1.5
-06	9/16-18	1.5	1.5	1.5	1.25
-08	3/4-16	1.5	1.5	1.25	1.25
-10	7/8-14	1.5	1.5	1	1
-12	1 1/16-12	1.25	1.25	1	1
-14	1 3/16-12	1.25	1.25	1	1
-16	1 5/16-12	1	1	1	1
-20	1 5/8-12	1	1	1	1
-24	1 7/8-12	1	1	1	1
-32	2 1/2-12	1	1	1	1

1) Recommended for use only when installation by torque method is not practical.

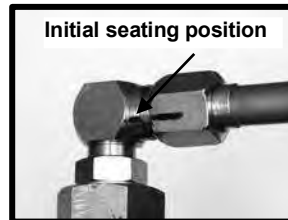

Fig.21 Mark finger tight position



Fig.22 Mark final tightening position

Assembly Instructions for O-Ring Port Non-Adjustable Stud Ends

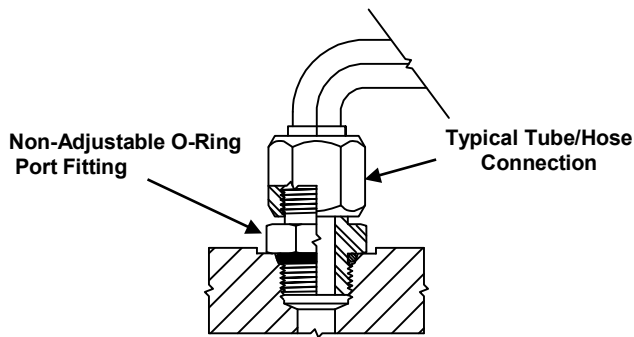

Fig. 13 Typical Non-Adjustable Stud End O-Ring Port Installation

1. Inspect components for damage or contamination.
2. If O-Ring is not present, install O-Ring on the port end of the connector using a proper O-Ring installation tool, taking care not to cut or nick the O-Ring.
3. Lubricate the O-Ring with a light coat of system fluid or compatible oil.
4. Screw stud into the O-Ring port and tighten to recommended torque listed in the following tables.

Assembly Torque, ISO 1179-3 Light Duty (L series) Stud Ends – Types G & H			
Dash Size	Thread Size	Ft. Lbs.	Nm.
-02	G 1/8	18-20	25-28
-04	G 1/4	37-41	50-55
-06	G 3/8	59-65	80-88
-08	G 1/2	77-85	105-116
-12	G 3/4	162-178	200-242
-16	G 1	273-300	370-407
-20	G 1-1/4	369-405	500-550
-24	G 1-1/2	442-486	600-660

Assembly Torque, ISO 6149-3 Light Duty (L Series) Stud Ends			
Tube Size mm	Thread Size	Ft. Lbs.	Nm.
-04	M8 x 1	6-7	8-9
-05	M10 x 1	11-12	15-17
-06	M12 x 1.5	18-20	25-28
-08	M14 x 1.5	26-28	35-39
-10	M16 x 1.5	29-32	40-44
-12	M18 x 1.5	33-36	45-50
-16	M22 x 1.5	44-49	60-66
-20	M27 x 2	74-81	100-110
-22	M30 x 2	96-105	130-143
-25	M33 x 2	118-130	160-176
-30	M42 x 2	155-170	210-231
-38	M48 x 2	192-211	260-286
-50	M60 x 2	232-255	315-347

Assembly Torque, SAE J1926-3 Light Duty (L series) Stud Ends (Ref. SAE J514 Tube Fittings and Port Plugs)			
Tube Size	Thread Size	Ft. Lbs.	Nm.
-02	5/16-24	6-7	8-9
-03	3/8-24	8-9	11-12
-04	7/16-20	13-15	18-20
-05	1/2-20	17-19	23-26
-06	9/16-18	22-24	29-33
-08	3/4-16	40-43	49-53
-10	7/8-14	43-48	59-64
-12	1-1/16-12	68-75	93-102
-14	1-3/16-12	90-99	122-134
-16	1-5/16-12	112-123	151-166
-20	1-5/8-12	146-161	198-218
-24	1-7/8-12	154-170	209-231
-32	2-1/2-12	218-240	296-325

Assembly Torque, ISO 6149-2 Heavy Duty (S Series) Stud Ends			
Tube Size mm	Thread Size	Ft. Lbs.	Nm.
-04	M8 x 1	7-8	10-11
-05	M10 x 1	15-16	20-22
-06	M12 x 1.5	26-28	35-39
-08	M14 x 1.5	33-36	45-50
-10	M16 x 1.5	41-45	55-61
-12	M18 x 1.5	52-57	70-77
-16	M22 x 1.5	74-81	100-110
-20	M27 x 2	125-138	170-187
-22	M30 x 2	158-174	215-237
-25	M33 x 2	228-251	310-341
-30	M42 x 2	243-268	330-363
-38	M48 x 2	310-340	420-462
-50	M60 x 2	369-405	500-550

Assembly Torque, SAE J1926-2 Heavy Duty (S series) Stud Ends (Ref. SAE J1453 ORFS Fittings)			
Tube Size	Thread Size	Ft. Lbs.	Nm.
-03	3/8-24	8-10	11-13
-04	7/16-20	14-16	20-22
-05	1/2-20	18-20	24-27
-06	9/16-18	24-26	33-35
-08	3/4-16	50-60	68-78
-10	7/8-14	72-80	98-110
-12	1-1/16-12	125-135	170-183
-14	1-3/16-12	170-190	230-260
-16	1-5/16-12	200-220	270-300
-20	1-5/8-12	210-280	285-380
-24	1-7/8-12	270-360	370-490

Assembly Torque, ISO 9974 Light Duty Stud Ends (O-Ring/Retaining Ring Type)			
Tube Size mm	Thread Size	Ft. Lbs.	Nm.
-05	M10 x 1	15-16	20-22
-06	M12 x 1.5	22-24	30-33
-08	M14 x 1.5	37-41	50-55
-10	M16 x 1.5	44-49	60-66
-12	M18 x 1.5	59-65	80-88
-16	M22 x 1.5	103-113	140-154
-20	M27 x 2	147-162	200-220
-25	M33 x 2	280-308	380-418
-30	M42 x 2	369-405	500-550
-38	M48 x 2	442-486	600-660

Assembly Instructions for Adjustable Stud End O-Ring Port Fittings

1. To protect the sealing surfaces and prevent dirt and other contaminants from entering the system, do not remove the protective caps and/or plugs until it is time to assemble the components.
2. Prior to assembly, remove protective caps and/or plugs and inspect the connector and the port to ensure both mating parts are free of burrs, nicks, scratches or any foreign material.
3. If O-Ring is not present, install O-Ring on the port end of the connector using a proper O-Ring installation tool, taking care not to cut or nick the O-Ring.
4. Lubricate the O-Ring with a light coat of system fluid or compatible oil.
5. Position #1 - The O-Ring should be located in the groove adjacent to the face of the back-up washer. The washer and O-Ring should be positioned at the extreme top end of the groove as shown.
6. Position #2 - Position the locknut to just touch the back-up washer as shown. The locknut in this position will eliminate potential back-up washer damage during the next step.
7. Position #3 - Install the connector into the straight thread port until the metal back-up washer contacts the face of the port as shown.
Caution: Over tightening beyond contact can cause washer damage, if the washer is not supported by the locknut.
8. Position #4 – Adjust the connector to the proper position by turning out (counterclockwise) up to a maximum of one turn as shown to provide proper alignment with the mating connector, tube assembly or hose assembly.
9. Position #5 - Using two wrenches, use the backup wrench to hold the connector in the desired position and then use the torque wrench to the tighten the locknut to the appropriate torque level shown in the following tables.
10. Visually inspect the joint, where possible, to ensure the O-Ring is not pinched or bulging out from under the washer and that the backup washer is properly seated flat against the face of the port.

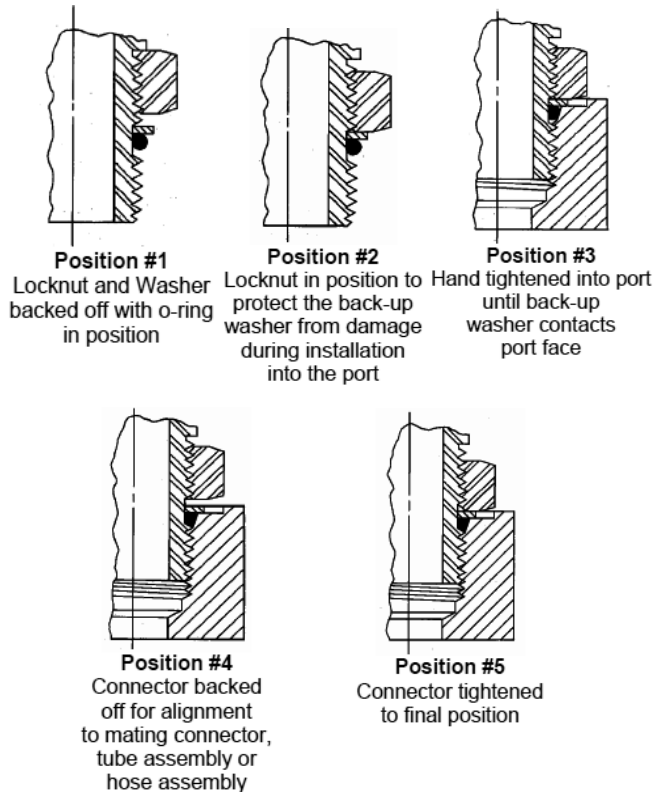

Assembly Torque, SAE J1926-2 Heavy Duty (S series) Stud Ends (Ref. SAE J1453 ORFS Fittings)			
Tube Size	Thread Size	Ft. Lbs.	Nm.
-03	3/8-24	8-10	11-13
-04	7/16-20	14-16	20-22
-05	1/2-20	18-20	24-27
-06	9/16-18	24-26	33-35
-08	3/4-16	50-60	68-78
-10	7/8-14	72-80	98-110
-12	1-1/16-12	125-135	170-183
-14	1-3/16-12	170-190	230-260
-16	1-5/16-12	200-220	270-300
-20	1-5/8-12	210-280	285-380
-24	1-7/8-12	270-360	370-490

Assembly Torque, SAE J1926-3 Light Duty (L series) Stud Ends (Ref. SAE J514 Tube Fittings and Port Plugs)			
Tube Size	Thread Size	Ft. Lbs.	Nm.
-02	5/16-24	6-7	8-9
-03	3/8-24	8-9	11-12
-04	7/16-20	13-15	18-20
-05	1/2-20	17-19	23-26
-06	9/16-18	22-24	29-33
-08	3/4-16	40-43	49-53
-10	7/8-14	43-48	59-64
-12	1-1/16-12	68-75	93-102
-14	1-3/16-12	90-99	122-134
-16	1-5/16-12	112-123	151-166
-20	1-5/8-12	146-161	198-218
-24	1-7/8-12	154-170	209-231
-32	2-1/2-12	218-240	296-325

Assembly Torque, ISO 1179-3 Light Duty (L series) Stud Ends – Types G & H			
Dash Size	Thread Size	Ft. Lbs.	Nm.
-02	G 1/8	18-20	25-28
-04	G 1/4	37-41	50-55
-06	G 3/8	59-65	80-88
-08	G 1/2	77-85	105-116
-12	G 3/4	162-178	200-242
-16	G 1	273-300	370-407
-20	G 1-1/4	369-405	500-550
-24	G 1-1/2	442-486	600-660

Assembly Torque, ISO 6149-3 Light Duty (L Series) Stud Ends			
Tube Size mm	Thread Size	Ft. Lbs.	Nm.
-04	M8 x 1	6-7	8-9
-05	M10 x 1	11-12	15-17
-06	M12 x 1.5	18-20	25-28
-08	M14 x 1.5	26-28	35-39
-10	M16 x 1.5	29-32	40-44
-12	M18 x 1.5	33-36	45-50
-16	M22 x 1.5	44-49	60-66
-20	M27 x 2	74-81	100-110
-22	M30 x 2	96-105	130-143
-25	M33 x 2	118-130	160-176
-30	M42 x 2	155-170	210-231
-38	M48 x 2	192-211	260-286
-50	M60 x 2	232-255	315-347

Assembly Torque, ISO 6149-2 Heavy Duty (S Series) Stud Ends			
Tube Size mm	Thread Size	Ft. Lbs.	Nm.
-04	M8 x 1	7-8	10-11
-05	M10 x 1	15-16	20-22
-06	M12 x 1.5	26-28	35-39
-08	M14 x 1.5	33-36	45-50
-10	M16 x 1.5	41-45	55-61
-12	M18 x 1.5	52-57	70-77
-16	M22 x 1.5	74-81	100-110
-20	M27 x 2	125-138	170-187
-22	M30 x 2	158-174	215-237
-25	M33 x 2	228-251	310-341
-30	M42 x 2	243-268	330-363
-38	M48 x 2	310-340	420-462
-50	M60 x 2	369-405	500-550

Assembly Torque, ISO 9974 Light Duty Stud Ends (O-Ring/Retaining Ring Type)			
Tube Size mm	Thread Size	Ft. Lbs.	Nm.
-05	M10 x 1	15-16	20-22
-06	M12 x 1.5	22-24	30-33
-08	M14 x 1.5	37-41	50-55
-10	M16 x 1.5	44-49	60-66
-12	M18 x 1.5	59-65	80-88
-16	M22 x 1.5	103-113	140-154
-20	M27 x 2	147-162	200-220
-25	M33 x 2	280-308	380-418
-30	M42 x 2	369-405	500-550
-38	M48 x 2	442-486	600-660

Assembly Instructions for NPTF and BSPT Pipe Threads

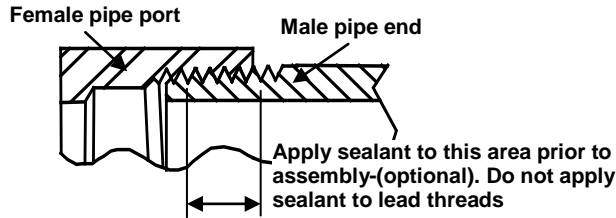

Fig.18 NPTF Pipe Assembly

Method A. Installation Torque

1. Inspect components for damage or contamination.
2. Lubricate or apply compatible sealant to male pipe thread. See Fig.18.
3. Screw fitting into port until hand tight. For shape fittings, take note of the intended alignment of the mating connectors.
4. For straight fittings, tighten to recommended torque listed in the following table. For shape fittings, approximately 1/2 turns should be made and then torque to the desired orientation without exceeding maximum recommended torque.

Assembly Torque, Adapter Unions and Pipe Fittings. (T.F.F.T. for Tapered Pipe Only) ¹					
Pipe Size	Adapter Unions		Pipe		
	Ft. Lbs. Max.	Nm. Max.	Ft. Lbs. Max.	Nm. Max.	Tapered Pipe T.F.F.T. ² (Turns)
1/8	13	18	12	16	3/4-1 3/4
1/4	20	27	25	34	3/4-1 3/4
3/8	25	34	40	54	3/4-1 3/4
1/2	47	64	54	73	1/2-1 1/2
3/4	84	114	78	106	1/2-1 1/2
1	129	175	112	152	1/2-1 1/2
1-1/4	152	206	154	209	1/2-1 1/2
1-1/2	152	206	211	286	1/2-1 1/2
2	300	407	300	407	1/2-1 1/2

1) Lubricated assembly.

2) Tapered pipe connections use turns from finger tight. Turn past minimum for alignment of shape fittings.

Method B. Turns From Finger Tight (T.F.F.T.)

Note: Due to the variety of factors which affect the turns method, the values indicated are approximate and should be used only for initial installation, by experienced installation personnel.

1. Inspect components for damage or contamination.
2. Lubricate or apply compatible sealant to male pipe thread.
3. Screw fitting into port and lightly wrench to seat threads.
4. Mark fitting and adjacent surface to indicate initial seating position.
5. For straight fittings, tighten using mean to maximum recommended T.F.F.T. listed in Table I.
6. For shape fittings, tighten to minimum T.F.F.T., and turn past to desired orientation.
7. Mark final tightening position by extending the existing mark from the fitting to the adjacent surface.

**Assembly Instructions for Adapter Unions/
Female NPSM Pipe Swivel Ends**

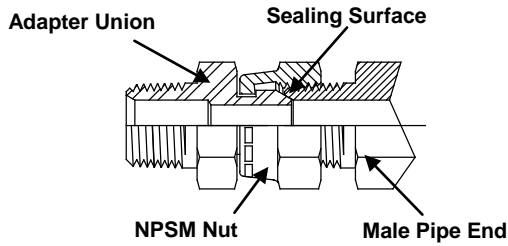

Fig.JA10 Adapter Union Assembly

1. Inspect components for damage or contamination.
2. Check for 30 degree female seat on male pipe end.
3. Align tube/hose to mating swivel allowing hand connection. To assure proper alignment, two to three turns of nut should be easily permitted.
4. Tighten swivel nut to recommended torque listed in the following table.

Notes: 1. Refer to the appropriate assembly instruction for adapter union port ends, i.e.: male pipe, female pipe or O-Ring straight thread.
 2. Female NPSM pipe swivels seal on the male nose of the female swivel end and the 30 degree female seat on the male pipe end. The NPSM swivel nut uses a straight mechanical pipe thread and is not a sealing member.
 3. Ensure that the male pipe end to be assembled has been machined with the optional 30 degree female seat. A standard 45 degree chamfer will not seal properly.

Assembly Torque, Adapter Unions and Pipe Fittings (T.F.F.T. for Tapered Pipe Only) ¹			
Pipe Size	Adapter Unions		Pipe
	Ft. Lbs. Max.	Nm. Max.	Tapered Pipe T.F.F.T. ² (Turns)
1/16	----	----	3/4-1 3/4
1/8	13	18	3/4-1 3/4
1/4	20	27	3/4-1 3/4
3/8	25	34	1/2-1 1/2
1/2	47	64	1/2-1 1/2
3/4	84	114	1/2-1 1/2
1	129	175	1/2-1 1/2
1-1/4	152	206	1/2-1 1/2
1-1/2	152	206	1/2-1 1/2
2	300	407	1/2-1 1/2

1) Lubricated assembly.
 2) Tapered pipe connections use turns from finger tight. Turn past for alignment of shape fittings.

Assembly Instructions for SAE J518-1 Code 61 and SAE J518-2 Code 62- Four Screw Split Flange Connections

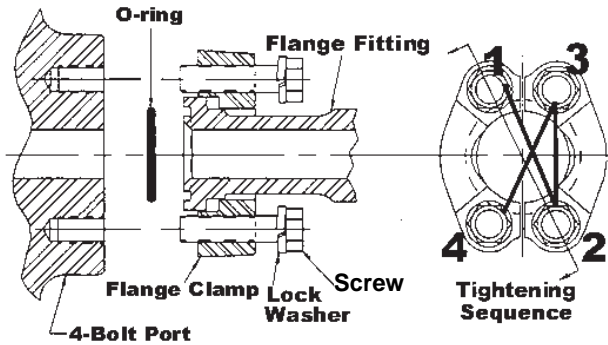

Fig.11 Four Screw Flange Fitting Assembly

1. Inspect components for damage or contamination.
2. Install correct O-Ring in flange groove.
3. Lubricate O-Ring and screw threads
4. Align flange and clamp halves to port.
5. Install screws, hand tighten evenly to seat O-Ring on port face.
6. Gradually tighten screws in equal increments, alternating in a diagonal pattern, to recommended torque listed in the following tables.

Assembly Torque, SAE J518-1 Code 61 Metric Flange Ends

Metric Size	Flange Size	Screw Size ¹	Ft. Lbs.	Nm.
13	1/2	M8 x 25	24	32
19	3/4	M10 x 30	52	70
25	1	M10 x 30	52	70
32	1-1/4	M10 x 30	52	70
38	1-1/2	M12 x 35	96	130
51	2	M12 x 35	96	130
64	2-1/2	M12 x 40	96	130

1) Lubricated assembly, Class 10.9 Screws.

Assembly Torque, SAE J518-2 Code 62 Metric Flange Ends

Metric Size	Flange Size	Screw Size ¹	Ft. Lbs.	Nm.
13	1/2	M8 x 30	24	32
19	3/4	M10 x 35	52	70
25	1	M12 x 45	96	130
32	1-1/4	M12 x 45	96	130
38	1-1/2	M16 x 55	217	295
51	2	M20 x 70	405	550

1) Lubricated assembly, Class 10.9 Screws

Assembly Torque, SAE J518-1 Code 61 Inch Flange Ends

Dash Size	Flange Size	Screw Size ¹	Ft. Lbs.	Nm.
-8	1/2	5/16-18 x 1-1/4	18	24
-12	3/4	3/8-16 x 1-1/4	32	43
-16	1	3/8-16 x 1-1/4	32	43
-20	1-1/4	7/16-14 x 1-1/2	52	70
-24	1-1/2	1/2-13 x 1-1/2	77	105
-32	2	1/2-13 x 1-1/2	77	105

1) Lubricated assembly, Grade 8 Screws.

Assembly Torque, SAE J518-2 Code 62 Inch Flange Ends

Dash Size	Flange Size	Screw Size ¹	Ft. Lbs.	Nm.
-8	1/2	5/16-18 x 1-1/4	24	32
-12	3/4	3/8-16 x 1-1/2	44	60
-16	1	7/16-14 x 1-3/4	68	92
-20	1-1/4	1/2-13 x 1-3/4	111	150
-24	1-1/2	5/8-11 x 2-1/4	217	295
-32	2	3/4-10 x 2-3/4	332	450

1) Lubricated assembly, Grade 8 Screws

Assembly Instructions for Beaded Hose Stem Connections

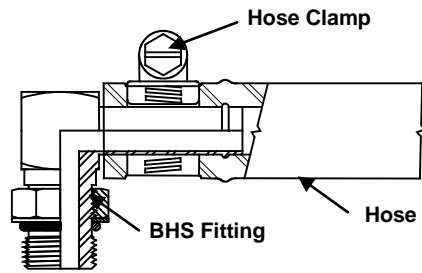

Fig.JA12 Typical Beaded Hose Stem Fitting Connection

1. Inspect components for damage or contamination.
2. Install hose clamp(s) on hose.
3. Lubricate hose I.D. if permissible.
4. Install hose to fitting.
5. Following hose and clamp manufacturers' instructions, tighten hose clamp(s).

Note: Beaded hose stem fittings are intended for use in suction or low pressure lines, typically less than 300 psi. Follow hose and hose clamp manufacturers instructions for specific application requirements.

Assembly Instructions for Silver Brazed Tube Connections

NOTE: The following instructions are not intended to replace detailed brazing procedures or process plans. Only qualified personnel should attempt to braze hydraulic system assemblies. For any application, sufficient testing should be conducted and reviewed by the user and manufacturer to assure safe and satisfactory performance.

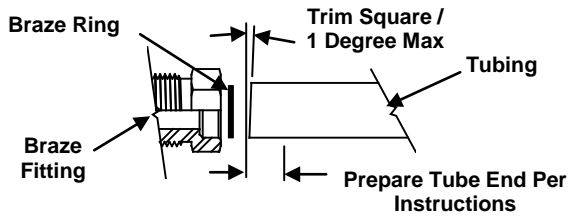

Typical Silver Braze Joint Assembly

1. Inspect components for damage or contamination.
2. Tube end to be brazed should be trimmed square to within +/- 1 degree.
3. Prepare tube end by sizing (if required) to achieve the recommended filler metal gap. Refer to braze alloy suppliers recommendations.
4. De-burr tube O.D. and I.D.. Typical chamfer size should not exceed .020 x 45 degree.
5. Clean all components with suitable degreasing solution to remove all oil/grease and loose contaminants. Following this degreasing step, avoid touching the braze joint surfaces with bare hands. Oil from your skin may contaminate the joint and cause voids and inclusions.

6. Mechanically clean or pickle surfaces to be brazed and braze filler material to remove surface oxides. Silicon carbide emery cloth may be used to polish joint surfaces, do not use abrasives containing aluminum oxide.
7. Final degrease all components.
8. Clamp or fixture tube assembly as required.
9. Apply suitable flux to all components, following flux manufacturers recommendations.
10. Assemble tube, braze ring (if used) and fitting components, reflux as required. Inspect to confirm proper placement of components prior to braze.
11. Apply heat uniformly to bring the joint area up to brazing temperature. Follow accepted industry practices for high quality braze joints. If specific brazing procedures have not been established for the fitting configurations being joined, refer to the flux and braze alloy manufacturers for recommendations.
12. Allow braze alloy to solidify completely before quenching.
13. Remove flux, following flux manufacturers instructions.
14. Inspect joint. Joint should show no evidence of voids in the fillet and should have no excess braze on the flange sealing surface area. Fillets should be smooth and continuous around the entire joint.
15. Proof test the assembly. Recommended proof pressure is two times the system operating pressure. Note: System operating pressure should not exceed the rated operating pressure of the end connections, tubing and/or hose components.

Assembly Instructions. Flares for Tubing

1. Select proper tubing for the application, including material compatibility, system fluid, operating pressure, mechanical loading, etc. For single flaring to SAE J533, SAE J524 or J525 tubing is recommended. For double flaring applications, tubing to SAE J524, J525, J526 or J356 may be used. For applications using stainless steel fittings, fully annealed tubing per ASTM A213, ASTM A249 or ASTM A269 is recommended
2. Prepare tube end by cutting to required length. End should be trimmed square within +/- 1°.
3. Deburr O.D. and I.D. of tube. Refer to Fig.24 and Table M for recommended tube chamfers for heavy wall tubing.
4. Clean tube to remove all dirt and grit from both O.D. and I.D. of tube.
5. Assemble tube nut and sleeve on tube. The threaded end of nut and flared end of sleeve must point toward the end of the tube to be flared.
6. Using the correct flaring tool for the tube size and desired flare angle, flare the tube end. Refer to Fig.23 for thin wall tubing flares and to Fig.24 for typical hydraulic system pressure line tubing flares.
7. Inspect flare to the dimensions indicated in Fig.23, Fig.24 and Table M. In addition, flare should be checked for concentricity, thin out, cracks, nicks, loose slivers, burrs, pits or other defects which may prevent sealing.

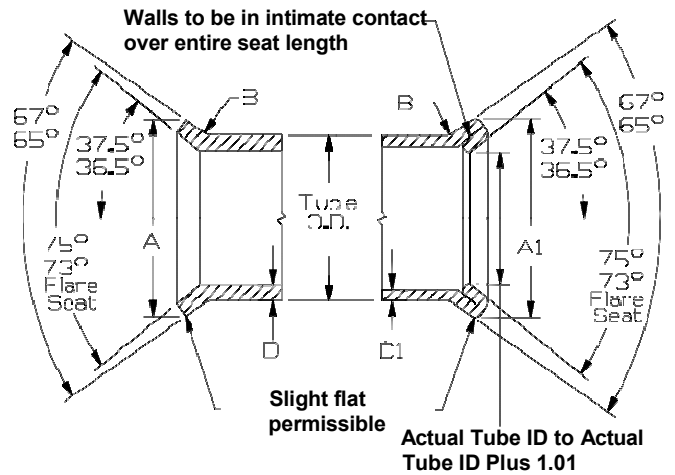

Fig.23 Single and Double 37° Flares for Tubing

1) Recommended for thin wall tubing flares

Table M. Dimensions of Single and Double 37° Flares for Tubing (Ref. SAE J533)

Dash Size	Nom. Tube Dia.	A and A1 Single and Double Flare Dia.	B Radius +/- 0.02	D Single Flare Tube Wall Max.	D1 Double Flare Tube Wall Max.	E Optional Tube Chamfer Face Width	F1 Dia. +/- .01
-02	1/8	.200-.180	0.03	0.035	0.025	.02+/- .005	.191
-03	3/16	.280-.260	0.03	0.035	0.028	.02+/- .005	.244
-04	1/4	.360-.340	0.03	0.065	0.035	.03+/- .005	.289
-05	5/16	.430-.400	0.03	0.065	0.035	.03+/- .005	.350
-06	3/8	.490-.460	0.04	0.065	0.049	.03+/- .005	.429
-08	1/2	.660-.630	0.06	0.083	0.049	.05+/- .010	.565
-10	5/8	.790-.760	0.06	0.095	0.049	.05+/- .010	.675
-12	3/4	.950-.920	0.08	0.109	0.049	.05+/- .010	.844
-14	7/8	1.070-1.040	0.08	0.109	0.065	.05+/- .010	.970
-16	1	1.200-1.170	0.09	0.120	0.065	.05+/- .010	1.094
-20	1-1/4	1.510-1.480	0.09	0.120	0.065	.05+/- .010	1.405
-24	1-1/2	1.730-1.700	0.11	0.120	0.065	.05+/- .010	1.620
-32	2	2.360-2.330	0.11	0.134	0.065	.06+/- .010	2.234

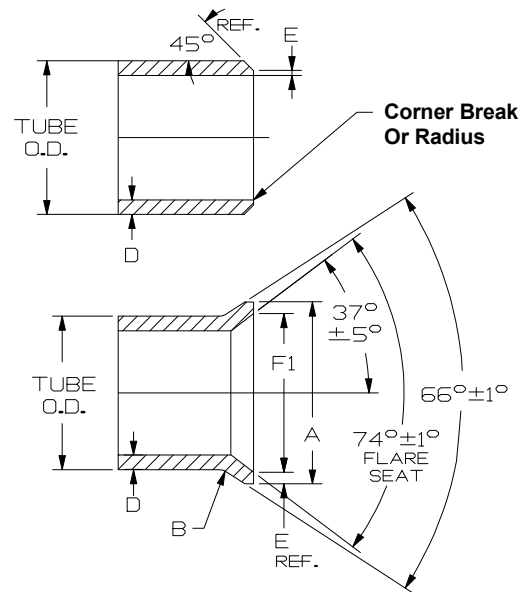

Fig.24 Optional Tube Preparation and Single 37° Flare for Tubing

1) Recommended for typical hydraulic system pressure line flares.

Assembly Instructions for O-Ring Face Seal Fittings and Adapters

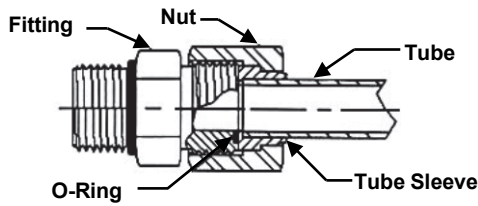
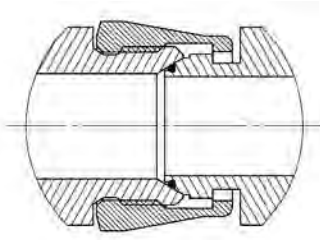

Fig.19 ORFS Fitting Assembly

Assembly Torque, O-Ring Face Seal Fittings			
Tube Size	Thread Size	Ft. Lbs.	Nm.
-04	9/16-18	10-12	14-16
-06	11/16-16	18-20	24-27
-08	13/16-16	32-35	43-47
-10	1-14	46-50	60-68
-12	1-3/16-12	65-70	90-95
-14	1-3/16-12	65-70	90-95
-16	1-7/16-12	92-100	125-135
-20	1-11/16-12	125-140	170-190
-24	2-12	150-165	200-225

1. Inspect components for damage or contamination.
2. If O-Ring is not present, install correct O-Ring in face groove taking care not to cut or nick the O-Ring.
3. Lubricate the O-Ring with a light coat of system fluid or compatible oil.
4. Align tube/hose to mating fitting allowing hand connection. Mating flat face end should fully contact O-Ring.
5. Tighten tube nut to recommended torque listed in the following table.

Assembly Instructions for 60° Cone Connectors



Tube Size mm	Thread Size	Ft. Lbs.	Nm.
6	G 1/8	7-8	10-11
8	G 1/4	15-16	10-22
10	G 3/8	26-28	35-39
12	G 1/2	37-41	50-55
16	G 5/8	44-49	60-66
20	G 3/4	63-69	85-94
25	G 1	85-93	115-127
32	G 1-1/4	140-154	190-209
38	G 1-1/2	177-195	240-264
50	G 2	221-243	300-330

1. Inspect components for damage or contamination.
2. If O-Ring is not present, install correct O-Ring in groove.
3. Lubricate the O-Ring with a light coat of system fluid or compatible oil.
4. Align tube/hose to mating fitting allowing hand connection. To assure proper alignment, two to three turns of nut should be easily permitted.
5. Tighten tube nut to torque listed in the following table.

Note: Air-Way is proud to be an active participant in the development of the text and the video format versions of SAE J1273 -

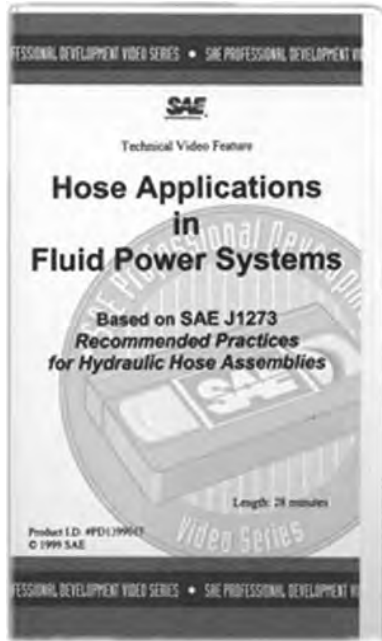

Recommended Practices for Hydraulic Hose Assemblies. These SAE documents are intended as guides to consider when selecting, routing, fabricating, installing, replacing, maintaining, and storing hose for fluid power systems. Proper consideration of these factors can have a direct impact on the satisfactory performance of hose/tube assemblies and the fittings to which they

are attached. Following the recommended practices outlined in SAE J1273 can reduce the likelihood of component or system failure. Air-Way supports these recommendations and can make a copy of the videotape version available to you on request. Please contact customer service for details.

Hose and Tube Routing

The following figures provide a summary of commonly accepted best practices for hose and tube routing. These figures are not intended to be all-inclusive, but represent situations frequently encountered in routing hydraulic system conductors. In addition to these figures, several general guidelines should be observed in the planning of a fluid power system layout.

1. Hydraulic system hose/tube assemblies and connectors are designed for the internal forces of conducted fluids. They are not designed to carry significant external loads. The routing and appropriate use of guards for these assemblies should protect them from external forces that could damage the hose/tube assembly or the fittings to which they are connected. Special attention should be given in areas where the assemblies are likely to be used as a step or are in exposed areas subject to impact, abrasion or snagging.
2. The pressurized fluids contained by the connectors and conductors in a fluid power system can cause property damage or personal injury. Some of the potential conditions to consider include:
 - a. Fluid Injection - Pinhole leaks in high-pressure circuits can allow the release of pressurized fluid that can

penetrate through the skin. **Fluid injection injuries can cause severe injury and potential loss of limb.** System planning should minimize the potential for fluid injections through careful routing, and the appropriate use of guards, shields and warnings in areas normally occupied by operators or maintenance personnel. **In the event of a fluid injection type injury, immediately seek medical treatment. Do not delay or treat as a simple cut.**

b. Burns - Hydraulic system fluids can reach temperatures high enough to burn skin. Component placement and system routing should be planned to minimize operator exposure to hot surfaces as well as potential contact with escaping fluids. Appropriate use of guards, shields and warnings should be considered in areas normally occupied by operators or maintenance personnel.

c. Physical Damage - In the event of a failure of a system component, physical damage can result from contact with ejected components, whipping hose or falling mechanisms. Loss of system control functions may result, such as sudden retraction of self-return mechanisms or loss of steering or brakes.

3. Proper alignment and assembly of components in a fluid power system is a major factor in the elimination of leaks and other system problems. Adequate space should be provided for access in all areas where connections need to be made during assembly or maintenance.

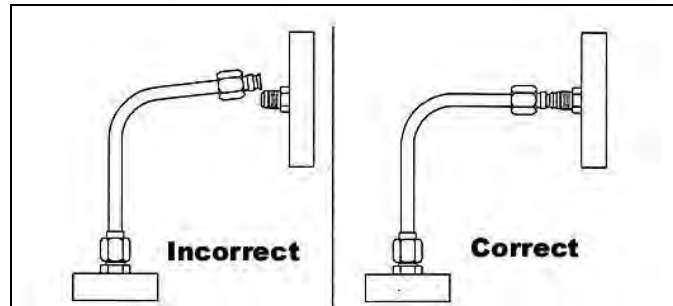

Fig.1 Check for proper component alignment. Correct misalignment prior to final assembly. Align hose/tube assembly allowing hand connection. To assure proper alignment, two to three turns of nut should be easily permitted by hand.

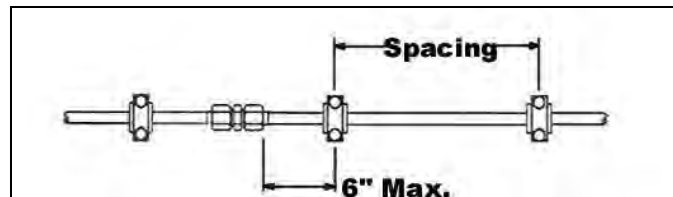

Fig.2 Use proper clamping to reduce strain due to vibration. See Table A for recommended clamp spacing. Final tightening of hose/tube connections should be completed before tightening of supports and clamps.

Table A. Clamp Spacing	
Tube O.D.	Spacing
1/4" - 1/2" (6.4 - 12.7 mm)	3 ft. (0.9 m)
5/8" - 7/8" (15.9 - 22.2 mm)	4 ft. (1.2 m)
1" (25.4 mm)	5 ft. (1.5 m)
1 1/4" and up (31.8 mm and up)	6 ft. (1.8 m)

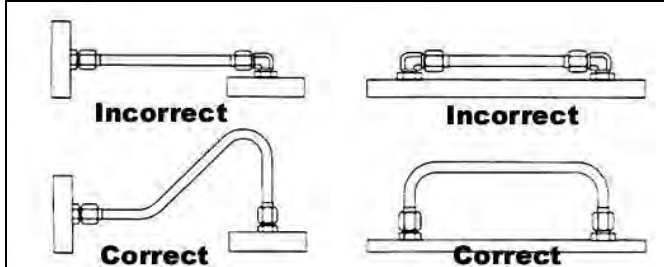

Fig.3 Use bends in hose/tube assemblies to reduce strain on components and to compensate for tolerance stack-up in assemblies.

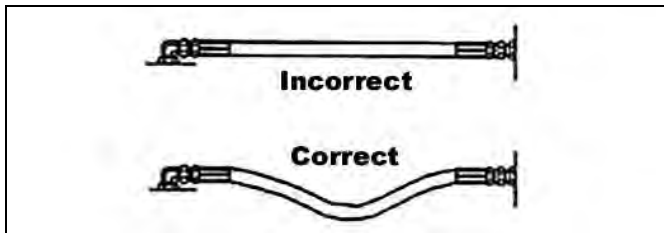

Fig.4 Allow extra hose length to reduce strain on components, to compensate for tolerance stack-up in assemblies and to allow for hose length changes when pressurized.

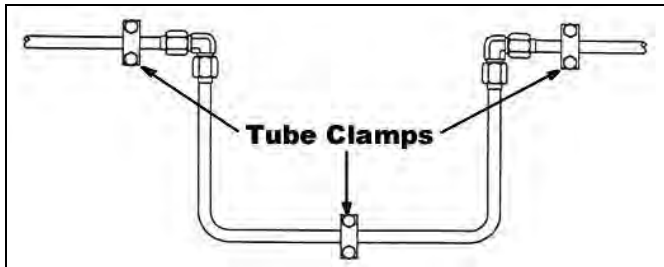

Fig.5 Use U-Bends to allow for expansion and contraction of rigid lines.

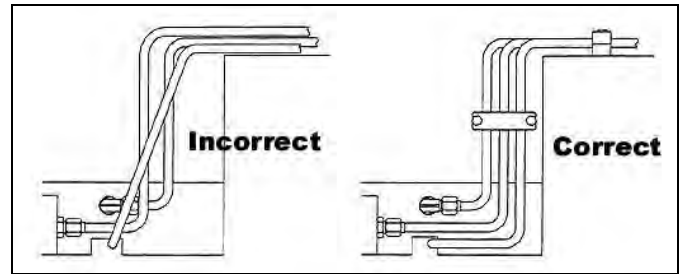

Fig.6 Route hose/tube assemblies to allow ease in assembly, maintenance and proper clamping.

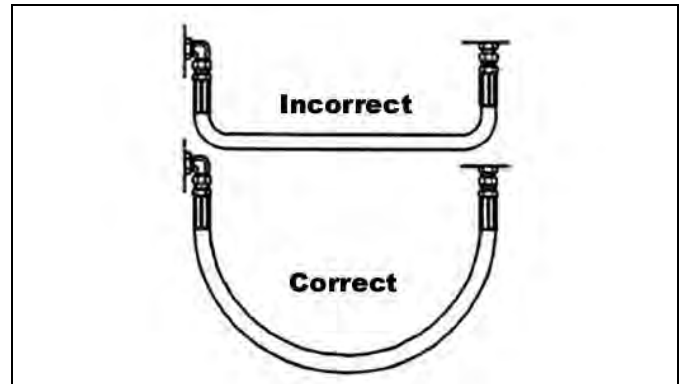

Fig.7 Hose manufacturers minimum bend radius recommendations should be observed for both static connections and for connections to moveable mechanisms. Bend radius for connections with moveable mechanisms should be checked over the entire range of motion to prevent damage to the hose/tube assembly or connectors.

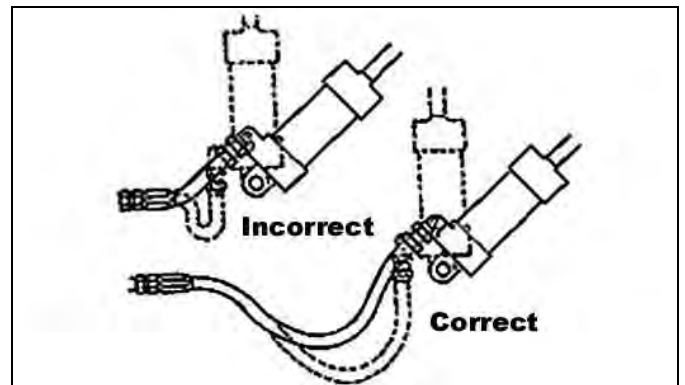

Fig.8 Provide adequate hose length to allow for movement of mechanisms. System design should provide sufficient hose length to prevent strain on connections at extreme extension and to prevent kinking of hose at any point throughout the entire range of motion. Either tensile strain or kinking can cause premature failure of hose/tube assemblies and connectors.

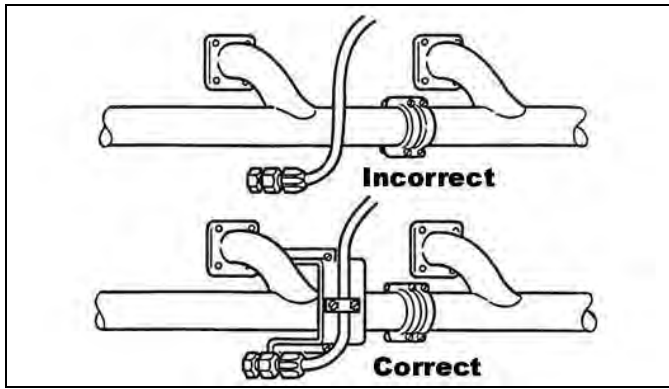

Fig.9 Provide shields/guards to protect hose/tube assemblies from potential damage. Examples include; heat sources such as exhaust manifolds/mufflers, abrasion/rubbing contact, contact with external objects.

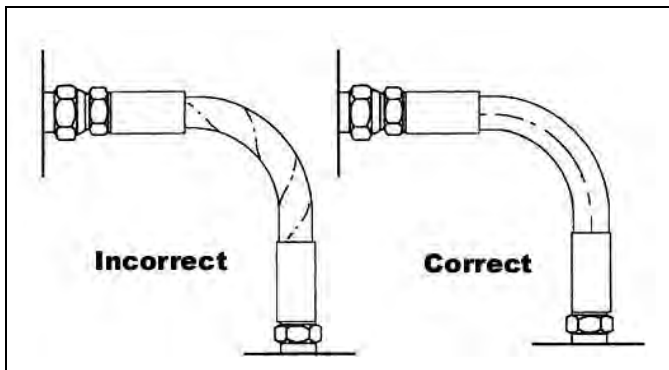

Fig.10 Use two wrenches when making hose connections to prevent hose twist. The hose lay-line may be used for visual reference. Twisting of the hose will result in reduced pressure capability and can cause loosening of the fitting when the hose is pressurized.

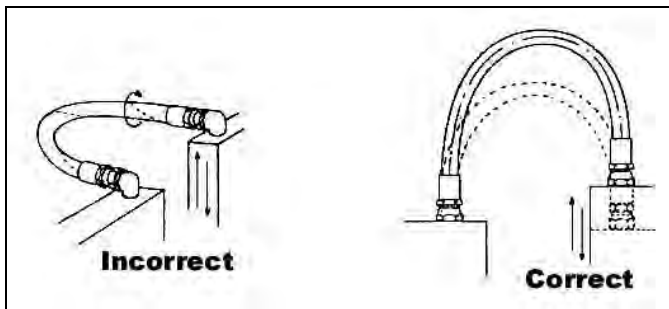

Fig.11 When routing hose assemblies between components that move in a single plane relative to each other, provide connections that result in movement of the hose in the same plane of motion without twisting. Evaluate the total range of motion of the hose assembly to ensure that the minimum bend radius is not violated. Twisting of the hose will result in reduced pressure capability and can cause loosening of the fitting when the hose is pressurized. Bending the hose tighter than the minimum bend radius can exert excessive force on the connections and will reduce the hose service life.

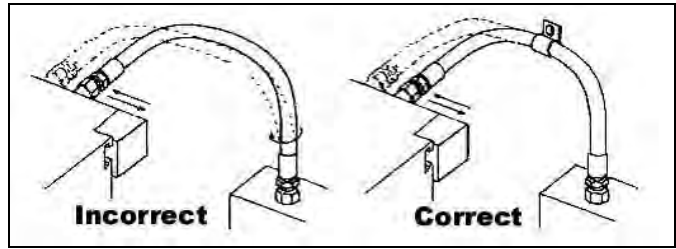

Fig.12 When routing hose assemblies between components which move in more than one plane relative to each other, provide clamping as required to isolate the motion to a single plane of bend for the hose. In installations where it is impossible to adequately clamp the hose assembly, use of live swivel joints in conjunction with proper clamping is recommended. Evaluate the total range of motion of the hose assembly to ensure that the minimum bend radius is not violated. Twisting of the hose will result in reduced pressure capability and can cause loosening of the fitting when the hose is pressurized. Live swivels permit rotational movement of the components under pressure without twisting of the hose. Bending the hose tighter than the minimum bend radius can exert excessive force on the connections and will reduce the hose service life.

Pressure Ratings, Steel Tubing for General Hydraulic System Applications

The following chart lists the nominal pressure ratings of tubing products which conform to SAE J524, SAE J525, SAE J526 and SAE J365. These pressure ratings are derived from the Lamé formula with 12,500 psi (86 MPa) allowable stress factors and approximately 4:1 design factor. Pressure values shown in bold are for tubing wall thickness normally considered suitable for 37 degree

single flaring to SAE J533. Many factors influence the pressure at which a hydraulic system will perform satisfactorily. The values shown below should not be used as a standard or specification and are not to be construed as guaranteed minimums.

Note: For single flaring to SAE J533, SAE J524 or J525 tubing is recommended. For double flaring applications, tubing to SAE J 524, J525, J526 or J356 can be used.

Nominal Tube O.D. inch mm	Nominal Tube Wall Thickness											
	0.028 0.71mm	0.035 0.89mm	0.049 1.24mm	0.065 1.65mm	0.083 2.11mm	0.093 2.41mm	0.109 2.77mm	0.120 3.05mm	0.134 3.40mm	0.148 3.76mm	0.156 3.96mm	0.188 4.78mm
Reference Working Pressures at 4:1 Design Factor(psi/MPa)												
0.125	6650	8450										
3.18	46.0	58.5										
0.188	4250	5450										
4.77	29.5	37.5										
0.250	3100	3950	5750	7800								
6.35	21.5	27.0	39.5	54.0								
0.312	2450	3100	4500	6150								
7.92	16.8	21.5	31.0	42.5								
0.375	2000	2550	3650	5000	6550	7600						
9.53	13.8	17.6	25.0	34.5	45.0	52.5						
0.500		1850	2700	3650	4800	5550	6450	7200				
12.70		12.8	18.6	25.0	33.0	38.5	44.5	49.5				
0.625		1500	2100	2850	3750	4350	5050	5600				
15.88		10.4	14.5	19.6	26.0	30.0	35.0	38.5				
0.750		1200	1750	2350	3050	3550	4150	4600				
19.05		8.3	12.0	16.2	21.0	24.5	28.5	31.5				
0.875		1050	1500	2000	2600	3000	3500	3900				
22.23		7.2	10.4	13.8	18.0	20.5	24.0	27.0				
1.000		900	1300	1750	2250	2600	3000	3350	3800	4200		
25.40		6.2	9.0	12.0	15.5	18.0	20.5	23.0	26.0	29.0		
1.125			1150	1550	2000	2300	2650	2950	3300	3700		
28.58			7.9	10.6	13.8	15.8	18.2	20.5	23.0	25.5		
1.250			1000	1350	1750	2050	2350	2650	2950	3300	3500	4300
31.75			6.9	9.3	12.0	14.2	16.2	18.2	20.5	23.0	24.0	29.5
1.500				1150	1450	1700	1950	2150	2450	2700	2850	3500
38.10				7.9	10.0	11.8	13.5	14.8	16.8	18.6	19.6	24.0
1.750				950	1250	1450	1650	1850	2050	2300	2400	2950
44.45				6.6	8.6	10.0	11.4	12.8	14.2	15.8	16.6	20.5
2.000				850	1100	1250	1450	1600	1800	2000	2100	2550
50.80				5.9	7.6	8.6	10.0	11.0	12.4	13.8	14.5	17.6

Calculation of Design Pressures for Alternate Tubing Materials

Design pressures for alternate tubing materials may be calculated using the Lamé formula as follows:

$P = S((D^2 - d^2) / (D^2 + d^2))$ where:

- D= nominal outside diameter of tubing
- d= nominal inside diameter of tubing
- P= design pressure
- S= allowable fiber stress of material at 4:1 design factor

Design stress and temperature derating factors for typical hydraulic system tubing materials and temperature ranges are listed below. Derating factors for SS-304 and SS-316 are derived from ASME B31.1-2012 Edition. Carbon steel tubing in these temperature ranges does not require derating.

Tubing Material	S= Allowable Fiber Stress @ 25% UTS Design Factor=4:1	Temperature Derating Factors		
		Temp.	SS304	SS316
C-1010	12,500 psi / 86MPa	100°F	1.00	1.00
C-1021	15,000 psi / 103 MPa	200°F	0.84	0.86
8630 GR	17,800 psi / 123 MPa	300°F	0.75	0.78
SS-304	18,800 psi / 130MPa	400°F	0.69	0.71
SS-316	18,800 psi / 130MPa	500°F	0.65	0.66

Note: This chart is intended as a guide only and is not a guarantee. Values shown are typical of generally available industry data and can be influenced by specific manufacturers' formulations or other factors. Suitability of materials is also influenced by many application specific factors including pressure, temperature, ambient conditions, concentration and anticipated service exposure. For any application, sufficient testing should be conducted and reviewed by the user and manufacturer to assure safe and satisfactory performance.

FLUID	SEALS				METAL		
	Buna-N	Neoprene	EPR/EPDM	Viton	Carbon Steel	Brass	316 SS
Codes: E = Excellent G = Good C = Conditional U = Unsatisfactory							
Acetaldehyde	U	C	G	U	G	E	E
Acetamide	G	G	E	G	-	-	E
Acetate Solvent	C	U	E	U	-	E	E
Acetic Acid, 5%-20%	U	U	E	G	U	U	C
Acetic Acid, Glacial	U	U	C	U	U	U	C
Acetic Anhydride	U	E	G	U	-	U	E
Acetone	U	U	G	U	E	E	E
Acetophenone	U	U	E	U	E	E	E
Acetyl Acetone	U	U	G	U	U	C	C
Acetyl Chloride	U	U	U	E	C	C	C
Acetylene	U	U	G	E	E	E	E
Air, Hot (Up to +160° F.)	E	E	E	E	E	E	E
Air, Hot (161°F -200° F.)	G	G	E	E	E	E	E
Air, Hot (201°F -300° F.)	U	U	G	E	E	E	E
Air Wet	E	E	E	E	U	G	E
Alcohols:							
Amyl Alcohol	G	G	E	G	G	G	E
Benzyl Alcohol	U	G	G	E	E	G	E
Butyl Alcohol	E	E	G	E	G	G	G
Diacetone Alcohol (Acetol)	U	U	E	U	E	E	E
Ethyl Alcohol (Ethanol)	E	E	E	E	E	E	E
Hexyl Alcohol (Hexanol)	E	G	C	C	E	G	E
Isobutyl Alcohol	G	G	E	E	E	G	E
Isopropyl Alcohol	G	G	E	E	E	E	E
Methyl Alcohol (Methanol)	G	G	E	U	G	G	E
Octyl Alcohol	E	E	E	E	E	E	E
Propyl Alcohol	E	E	E	E	E	E	E
Aluminum Chloride	E	E	E	E	U	U	U
Aluminum Fluoride	E	E	E	E	U	U	U
Aluminum Nitrate	E	E	E	E	U	U	C
Aluminum Sulfate	E	E	E	E	U	C	E
Alums	E	E	E	E	U	C	E
Ammonia, Cold	E	E	E	U	E	U	E
Ammonia, Hot	U	G	G	U	E	U	E
Ammonia, Anhydrous	E	E	E	U	E	U	E
Ammonia, Aqueous	E	E	E	U	E	U	E
Ammonium Carbonate	U	E	E	U	C	U	C
Ammonium Chloride	E	E	E	U	U	U	C
Ammonium Hydroxide	C	C	E	C	G	U	C
Ammonium Nitrate	E	G	E	U	G	U	G
Ammonium Phosphate	E	E	E	-	U	C	G
Ammonium Sulfate	E	E	E	U	U	U	G
Ammonium Sulfite (to +72°F)	E	E	E	U	-	-	G
Amyl Acetate	U	U	G	U	E	E	E
Aniline Oil	U	U	G	U	E	U	E

FLUID	SEALS				METAL		
	Buna-N	Neoprene	EPR/EPDM	Viton	Carbon Steel	Brass	316 SS
Codes: E = Excellent G = Good C = Conditional U = Unsatisfactory							
Aniline Dyes	U	G	G	G	U	C	G
Arsenic Acid	E	E	E	E	U	U	G
Asphalt	G	C	U	E	E	G	E
ASTM Oil # 1	E	E	C	E	E	E	E
ASTM Oil # 2	E	G	U	E	E	E	E
ASTM Oil # 3	E	G	U	E	E	E	E
Automatic Trans. Fluid	E	G	U	E	E	E	E
Barium Chloride	E	E	E	E	U	G	G
Barium Hydroxide	E	E	E	E	G	U	G
Barium Sulfide	E	E	E	E	C	U	G
Benzene, Benzol	U	U	U	E	G	E	E
Benzin	E	U	U	E	E	E	E
Benzoic Acid	U	U	U	E	U	G	G
Black Sulfate Liquor	C	C	C	E	E	C	E
Blast Furnace Gas	U	U	U	E	E	C	E
Borax	G	G	E	E	E	E	E
Boric Acid	G	G	G	E	U	G	C
Brine	E	G	E	E	U	G	G
Bromine	U	U	U	E	U	C	U
Butane	E	E	U	E	E	E	E
Butyl Acetate	U	U	G	U	E	E	E
Butyl Cellosolve	U	U	G	U	E	E	E
Butylene	C	U	U	E	E	E	E
Butyl Stearate	G	U	U	E	G	G	G
Butyraldehyde	U	U	G	U	E	E	E
Calcium Acetate	G	G	E	U	G	G	G
Calcium Bisulfate	E	E	U	E	U	C	C
Calcium Chloride	E	E	E	E	G	G	G
Calcium Hydroxide	E	E	E	E	G	G	G
Calcium Hypochlorite	U	U	E	E	U	G	C
Calcium Nitrate	E	E	E	E	G	G	G
Cane Sugar Liquors	E	E	E	E	E	G	E
Carbitol	G	G	G	G	E	E	E
Carbolic Acid	U	U	G	E	U	E	E
Carbonic Acid	G	E	E	E	U	C	E
Carbon Dioxide	G	G	E	E	E	E	E
Carbon Disulfide	U	U	U	E	G	G	G
Carbon Monoxide	G	G	E	E	E	E	E
Carbon Tetrachloride	U	U	U	E	U	G	G
Castor Oil	E	E	G	E	E	E	E
Chlorine	U	U	U	G	C	C	C
Chloroacetic Acid	U	U	G	U	U	U	U
Chloroacetone	U	U	E	U	G	G	G
Chlorobenzene	U	U	U	G	G	G	G
Chloroform	U	U	U	E	G	G	G
Chlorosulfonic Acid	U	U	U	U	-	U	G
Chrome Plating Solution	U	U	G	E	C	U	U
Chromic Acid	U	U	C	E	C	U	U
Citric Acid	E	E	E	E	C	C	C
Coke Oven Gas	U	U	U	E	E	C	E
Copper Chloride	E	E	E	E	U	U	U
Copper Cyanide	E	E	E	E	E	U	G
Copper Sulfate	E	E	E	E	U	C	G
Cotton Seed Oil	E	G	C	E	E	E	E
Creosote (Coal Tar)	G	C	U	E	E	C	E
Crude Oil	E	G	U	E	G	U	G
Cyclohexanol	E	G	U	E	E	E	E
Cyclohexanone	U	U	G	U	E	E	E
Detergent/Water Solution	E	E	E	E	G	E	E
Dibenzyl Ether	U	U	G	U	G	G	G
Diesel Oil	E	C	U	E	E	E	E

Diethylamine	G	G	G	U	E	U	E
Diethyl Phthalate (DOP)	U	U	G	G	E	E	E
Dowtherm A, Dowtherm E	U	U	U	E	G	U	E
Ethane (to +72°F)	E	G	U	E	-	-	E
Ether (to +72°F)	U	U	C	C	-	G	E
Ethanolamine	G	G	G	U	-	-	E
Ethyl Acetate	U	U	G	U	E	E	E
Ethyl Benzene	U	U	U	E	E	G	G
Ethyl Cellulose	G	G	G	U	E	G	G
Ethyl Chloride	U	U	U	E	E	E	E
Ethylene Dichloride	U	U	U	G	G	C	G
Ethylene Glycol	E	E	E	E	E	G	E
Ferric Chloride	E	G	E	E	U	U	U
Ferric Nitrate	E	E	E	E	U	U	G
Ferric Sulfate	G	G	G	E	U	U	E
Formaldehyde	C	C	G	G	E	E	E
Formic Acid	C	G	E	U	U	C	C
Fuel Oil	E	G	U	E	E	E	E
Furfural	C	C	G	U	G	G	G
Gallic Acid	G	G	G	E	U	-	G
Gasoline	E	C	U	E	E	E	E
Gasohol	G	G	U	E	E	E	E
Glycerine/Glycerol	E	E	E	E	E	G	E
Green Sulfate Liquor	G	G	E	E	U	U	E
Helium	E	E	E	E	E	E	E
Heptane	E	G	U	E	E	G	E
Hexaldehyde	U	G	G	U	G	G	E
Hexane	E	G	U	E	E	E	E
Hydraulic Oils:							
Straight Petroleum Base	E	G	U	E	E	E	E
Water Petroleum Emulsion	E	G	U	E	C	E	E
Water Glycol	E	E	E	E	E	E	E
Straight Phosphate Ester	U	U	G	C	E	E	E
Phos. Ester/Petroleum Blend	U	U	U	C	E	E	E
Ester Blend	E	U	U	E	E	E	E
Silicone Oils	E	E	E	E	E	E	E
Hydrobromic Acid	U	U	E	E	E	U	E
Hydrochloric Acid	U	U	G	E	U	U	U
Hydrocyanic Acid	C	C	E	E	E	E	G
Hydrofluoric Acid	U	U	C	U	U	U	U
Hydrofluorosilic Acid	G	G	E	E	U	U	U
Hydrogen	E	E	E	E	E	E	E
Hydrogen Peroxide	G	G	E	U	U	G	
Hydrogen Sulfide, Dry	U	G	E	U	E	G	G
Isocyanate	U	U	G	E	G	-	G
Iso Octane	E	G	U	E	E	E	E
Isopropyl Acetate	U	U	G	U	E	-	E
Isopropyl Ether	G	U	U	U	G	G	G
JP-4, JP-5	E	U	U	E	E	E	E
Kerosene	E	U	U	E	E	E	E
Ketones	U	U	E	U	-	-	E
Lacquer/Lacquer Solvents	U	U	U	U	U	E	E
Lime Sulfur	U	E	E	E	G	U	G
Linseed Oil	E	G	U	E	E	E	E
LPG	E	G	U	E	E	E	E
Lubricating Oils: See							
Hydraulic Oils							
Magnesium Chloride	E	E	E	E	E	C	C
Magnesium Hydroxide	G	G	E	E	E	G	E
Magnesium Sulfate	E	E	E	E	E	E	E
Maleic Acid	U	U	U	E	E	G	G
Maleic Anhydride	U	U	U	E	G	U	E
Malic Acid	G	G	U	G	U	-	E
Mercuric Chloride	E	E	E	E	U	U	U
Mercury	E	E	E	E	E	U	E
Methyl Bromide	G	U	U	E	E	E	G
Methyl Chloride	U	U	U	E	E	E	E
Methyl Butyl Ketone	U	U	E	U	E	E	E
Methyl Ethyl Ketone	U	U	E	U	G	G	G

Methylene Chloride	U	U	U	G	G	G	G
Methyl Isobutyl Ketone	U	U	U	U	G	G	G
Methyl Isopropyl Ketone	U	U	U	U	G	G	G
Methyl Salicylate	U	U	C	U	E	G	G
MIL-L-2104	E	G	U	E	E	E	E
MIL-O-5606	E	G	U	E	E	E	E
MIL-H-6083	E	E	U	E	E	E	E
MIL- L-7808	G	U	U	E	G	G	E
MIL-L-23699	G	U	U	E	E	E	E
MIL-H-46170	E	G	U	E	E	E	E
MIL-H-83282	E	E	U	E	E	E	E
Mineral Oils	E	G	U	E	E	E	E
Naphtha	C	U	U	E	-	E	E
Naphthalene	U	U	U	E	E	G	E
Naphthenic Acid	C	U	U	E	-	G	E
Natural Gas	E	E	U	E	G	G	G
Nickel Acetate	C	C	E	G	G	C	E
Nickel Chloride	E	G	E	E	U	U	G
Nickel Sulfate	E	E	E	E	U	G	G
Nitric Acid, to 10%	U	U	U	E	U	U	E
Nitric Acid, over 10%	U	U	U	G	U	U	E
Nitrobenzene	U	U	U	G	E	G	E
Nitrogen	E	E	E	E	E	E	E
Oleic Acid	U	U	C	G	C	E	G
Oleum (Mineral Spirits)	E	G	U	E	E	E	E
Ortho- Dichlorobenzene	U	U	U	E	G	G	G
Oxalic Acid	G	G	E	E	U	C	C
Oxygen	-	-	-	-	G	G	G
Palmitic Acid	E	G	G	E	G	U	E
Para-Dichlorobenzene	U	U	U	E	G	G	G
Pentane	E	E	U	E	G	G	G
Perchloric Acid	E	G	G	E	U	U	U
Perchloroethylene	U	U	U	E	C	G	G
Phenol (Carbolic Acid)	U	U	U	E	U	U	G
Phosphoric Acid	U	U	G	E	U	E	E
Phosphorous Trichloride	U	U	E	E	C	U	C
Potassium Acetate	G	G	E	U	C	G	C
Potassium Chloride	E	E	E	E	E	C	E
Potassium Cyanide	E	E	E	E	C	U	G
Potassium Dichromate	E	E	E	E	C	C	C
Potassium Hydroxide (to 10%)	G	G	E	G	G	G	G
Potassium Hydroxide (over 10%)	C	C	E	U	G	G	G
Potassium Nitrate	E	E	E	E	G	G	E
Potassium Sulfate	E	E	E	E	-	U	E
Propane	E	C	U	E	E	E	E
Propyl Acetate	U	U	G	U	E	-	E
Propylene	U	U	U	E	E	E	E
Refrigerant R-12	G	E	C	E	E	E	E
Refrigerant R-13	G	E	C	E	E	E	E
Refrigerant R-22	U	E	C	U	E	E	E
Sewage	E	E	E	E	E	G	G
Soap (Water Solutions)	E	E	E	E	E	E	E
Sodium Acetate (to +72°F)	G	G	E	U	-	G	G
Sodium Bicarbonate	E	E	E	E	G	G	E
Sodium Borate	E	E	E	E	E	E	E
Sodium Carbonate	E	E	E	E	E	G	E
Sodium Chloride	E	E	E	E	U	C	C
Sodium Cyanide	E	E	E	E	E	-	C
Sodium Hydroxide (to 10%)	U	G	E	E	C	G	C
Sodium Hydroxide (over 10%)	U	U	G	E	C	C	C
Sodium Hypochlorite	C	C	E	C	U	U	U
Sodium Metaphosphate	E	E	E	E	U	G	G
Sodium Nitrate (to +72°F)	G	G	E	G	E	C	G
Sodium Perborate	G	G	E	E	C	U	C
Sodium Peroxide	G	G	E	E	U	U	C
Sodium Phosphates	E	E	E	E	U	E	G
Sodium Silicate	E	E	E	E	E	E	E

Technical Data

Fluid Compatibility

Sodium Sulfate	E	E	E	E	G	G	G
Sodium Sulfide	E	E	E	E	C	U	C
Sodium Thiosulfate	G	E	E	E	U	U	C
Soy Bean Oil	E	G	U	E	E	E	E
Stannic Chloride	E	G	E	E	U	U	U
Stannous Chloride (to 72°F)	E	E	C	E	-	-	E
Steam (up to 388° F)	U	U	C	C	E	E	E
Stearic Acid	G	G	G	E	C	C	E
Stoddard Solvent	E	G	U	E	E	E	E
Styrene	U	U	U	G	E	E	E
Sulfur	U	E	E	E	E	U	G
Sulfur Chloride	U	U	U	E	-	U	U
Sulfur Dioxide	U	U	G	E	E	G	G
Sulfur Trioxide	U	U	G	E	G	C	G
Sulfuric Acid (to 10%)	U	G	U	E	U	G	C
Sulfuric Acid (over 10%)	U	U	U	G	C	C	U
Sulfurous Acid	C	C	U	U	U	C	C
Tannic Acid	E	E	E	E	E	E	E
Tar (Bituminous)	G	U	U	E	E	G	E
Tartaric Acid	E	G	G	E	U	C	C
Tertiary Butyl Alcohol	G	G	G	E	G	G	G
Titanium Tetrachloride	C	U	U	E	E	U	G
Toluene (Toluol)	U	U	U	E	E	E	E

Trichloroethane	U	U	U	E	E	-	E
Trichloroethylene	U	U	U	E	E	G	E
Tricresylphosphate (to 120°F)	U	C	E	G	E	-	G
Triethanolamine	U	G	E	U	E	U	E
Tung Oil	G	G	U	E	E	G	E
Turpentine	G	U	U	E	G	G	G
Varnish	G	U	U	E	E	G	E
Vinyl Chloride	U	U	U	E	E	U	C
Water:							
Water (to +150°F)	E	E	E	E	C	G	E
Water (+151°F to +200°F)	E	E	E	E	C	G	E
Water (+201°F to +350°F)	U	U	U	G	C	G	E
Water, Deionized (to 72°F)	E	E	E	E	U	E	E
Water, Deionized (to 120°F)	-	E	-	-	U	E	E
Water, Distilled	E	E	E	E	C	E	E
Water, Salt	E	E	E	E	U	U	G
Xylene	U	U	U	E	E	E	E
Zinc Chloride	E	E	E	E	E	U	U
Zinc Sulfate	E	E	E	E	U	C	G

Features, 37 Degree Tube Fittings

37 degree flared tube fittings provide leakproof, full flow connections in hydraulic systems operating at working pressures as specified in the tables below. A large variety of fitting styles are available to allow connection of flared tube ends, machined male or female 37 degree ends or male or female NPTF pipe or hose ends. Also included in this section are low-pressure beaded hose stem fittings.

37 degree flared fittings are the most commonly used tube connection in worldwide use today. Tube preparation and flaring processes are easily accomplished with either hand or power tools. The large variety of fitting configurations and jump sizes available provide for simplified fabrication requirements and reduced parts count in complex systems.

The design of the 37 degree flared fitting tube end is identical for either inch or metric tubing. With the exception of stock size, the flared tube fittings described in this section are interchangeable with equivalent fitting styles (unions, bulkheads, tees, etc.) per ISO 8434-2.

All 37 degree fitting styles are also available with the optional **FLARE-O**[®] tube end design. Call for details.

Performance

Where applicable, fittings are designed and qualified to the requirements of SAE J514.

Construction

Unless otherwise specified, fittings are machined from cold drawn carbon steel barstock and forgings. Standard plating is electrodeposited zinc with a clear trivalent chromate conversion coating in accordance with ASTM B633 (Type V SC2). The minimum salt spray resistance is 240 hours to red corrosion when tested in accordance with ASTM B117

Threads

Straight Threads: Internal and external straight threads conform to the Unified National Class 2A and Class 2B Series respectively, with modified minor diameters where specified. Plated external threads may conform to Class 3A maximum diameters after plating.

NPTF Threads: Male and female pipe threads conform to the Dryseal American Standard Taper Pipe Thread (SAE J476a, NPTF) Series which will provide pressure tight joints without the use of a lubricant or sealer. Use of these fittings with non-dryseal NPT pipe or hose ends is not recommended for high-pressure applications.

Note: Where not functionally objectionable, use of a compatible lubricant/sealant is recommended for either NPT or NPTF threads to minimize the possibility of galling in assembly.

Assembly Information

For assembly instructions, refer to the Technical Data Section for the appropriate fitting end. Also, refer to the Technical Data Section for recommendations regarding tubing pressure ratings, tube flares and hose/tube routing information. Please note the following:

Tubing for single flare tube ends should be either seamless or welded and drawn, fully annealed tubing per SAE J524 or J525. For double flaring, tubing per SAE J356, J524, J525 or J526 may be used.

For proper sealing with 37 degree flared fittings, flares for tubing should conform to the requirements of SAE J533. For heavy wall tubing, the optional tube preparation and single flare configuration specified in SAE J533 is also recommended. This optional configuration provides extended sealing surface contact area versus conventional flares.

In the design and fabrication of tubing or hose runs for any hydraulic system, precautions should be taken to allow for sufficient adjustment of the hose or tubing so that proper alignment can be attained at the fitting connections. Improper fit-up or misalignment should be corrected before final connections are made. Location of fitting connections should be planned to maximize accessibility. Whenever possible, use a torque wrench to tighten connections to the recommended installation torque.

Ordering Information

Size of fittings are indicated by dash number relating to sixteenths of an inch for the nominal O.D. of the tube size used. Example: 1/2 inch tube = 8/16 or (-8) size.

Order standard fittings from appropriate chart indicating required dash numbers. For example, 2501-8-6 is 1/2" tube end with 3/4-16 straight thread and 3/8" male pipe thread. Jump size 2501-8-12 is 1/2" tube end with 3/4-16 straight thread and 3/4" male pipe thread. Pictorial views for each fitting style indicate the correct numbering sequence for fitting ends.

Bulkhead fittings may be ordered with or without lock nuts. To order fittings with lock nut, add (-LN) suffix to base catalog part number.

If information is needed for jump sizes not shown, please contact customer service for engineering assistance. Dimensions are rounded for brevity. Please contact factory for exact dimensions and tolerances.

Table JT1. Pressure Ratings for 37 Deg. Flared Tube Ends, Unions, Bulkheads and 37 Deg. Female Swivels

Nominal Tube Size		Thread Size	Working Pressures			
Nom SAE Dash Size	Nom Inch Tube O.D.	SAE J514 Flared Tube End and SAE J1926/3/ ISO 11926-3 O-Ring Port Thread Size (Notes 1&2)	37 Deg. Flared Tube Ends, Unions and Bulkheads		37 Deg. Female Swivels	
			MPa	psi	MPa	psi
-02	1/8	5/16-24 UNF	34.5	5,000	34.5	5,000
-03	3/16	3/8-24 UNF	34.5	5,000	34.5	5,000
-04	1/4	7/16-20 UNF	34.5	5,000	31	4,500
-05	5/16	1/2-20 UNF	34.5	5,000	27.5	4,000
-06	3/8	9/16-18 UNF	34.5	5,000	27.5	4,000
-08	1/2	3/4-16 UNF	31	4,500	27.5	4,000
-10	5/8	7/8-14 UNF	24	3,500	21	3,000
-12	3/4	1-1/16-12 UN	24	3,500	21	3,000
-14	7/8	1-3/16-12 UN	21	3,000	17	2,500
-16	1	1-5/16-12 UN	21	3,000	17	2,500
-20	1 1/4	1-5/8-12 UN	17	2,500	14	2,000
-24	1 1/2	1-7/8-12 UN	14	2,000	10.5	1,500
-32	2	2-1/2-12 UN	10.5	1,500	8	1,125











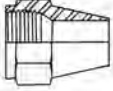

1) Threads per SAE J475 Class 2A ext. Class 2B int. (Ref. ISO-263/ISO-R725)

2) Unified class 2B threads apply to swivel nuts and with minor diameter modified to class 3B limits for locknuts

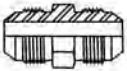
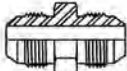
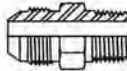
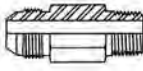
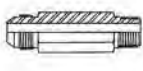
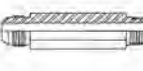
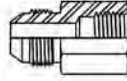
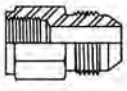
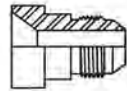
Table JT2. Pressure Ratings for Fittings With NPTF Pipe Threads

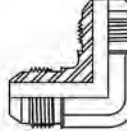
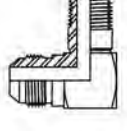
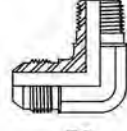
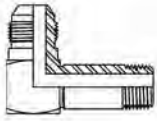
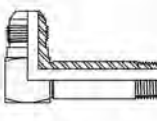
Nominal Pipe Size		Thread Size	Working Pressures	
Nom SAE Dash Size	Nom Inch Pipe O.D.	Dryseal Pipe Thread (NPTF ¹) Male and Female	Fittings With NPTF Pipe Threads	
			MPa	psi
-02	1/8	1/8-27	34.5	5,000
-04	1/4	1/4-18	27.5	4,000
-06	3/8	3/8-18	21	3,000
-08	1/2	1/2-14	21	3,000
-12	3/4	3/4-14	17	2,500
-16	1	1-11-1/2	14	2,000
-20	1 1/4	1-1/4-11-1/2	8	1,150
-24	1 1/2	1-1/2-11-1/2	7	1,000
-32	2	2-11-1/2	7	1,000

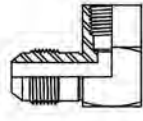
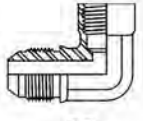
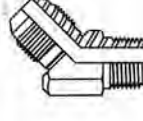
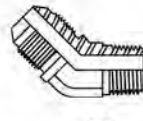
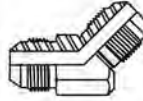
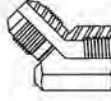
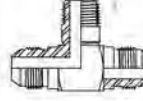
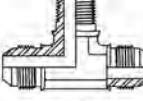
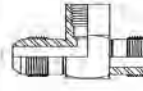
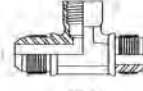
1) Dryseal American Standard Taper Pipe Thread

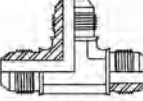
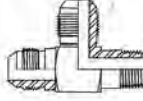
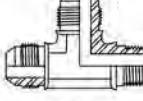
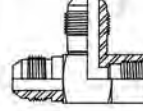
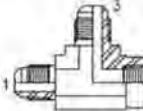
 0302- Short Nut	(070111)  0304- Standard Nut	(070112)  0304-C- Cap Nut	(070118)  0306-LN- Bulkhead Lock Nut	(070117)  0306-N- Adjustable Lock Nut	(070110)  0318- Tube Nut	(070115)  0319- Tube Sleeve
(070101)  2403- (1&2)Male Tube	(070119)  2403-LH- (1&2)Male Tube Large Hex	(070102)  2404- (1)Male Tube (2)Male Pipe	(070102)  2404-L- (1)Male Tube (2)Male Pipe-Long	(070102)  2404-LL- (1)Male Tube (2)Male Pipe-X-Long	(070102)  2404-LLL- (1)Male Tube (2)Male Pipe-XX-Long	(070103)  2405- (1)Male Tube (2)Female Pipe
 2406- (1)37° Female (2)Male Tube	(070123)  2407- (1)37° Female (2)Male Tube	(070109)  2408- (1)Male Tube	(070201)  2500- (1&2)Male Tube FG	(070201)  2501- (1)Male Tube (2)Male Pipe FG	(070202)  2501- (1)Male Tube (2)Male Pipe FG	(070202)  2501- (1)Male Tube (2)Male Pipe FG
(071502)  2501-L- (1)Male Tube (2)Male Pipe-Long	(071602)  2501-LL- (1)Male Tube (2)Male Pipe-X-Long	(071602)  2501-LLL- (1)Male Tube (2)Male Pipe-XXX-Long	(070203)  2502- (1)Male Tube (2)Female Pipe FG	(070203)  2502- (1)Male Tube (2)Female Pipe FG	(070302)  2503- (1)Male Tube (2)Male Pipe FG	(070302)  2503- (1)Male Tube (2)Male Pipe FG
 2504- (1)Male Tube (2)Male Tube	 2505- (1)Male Tube (2)Female Pipe	(070425)  2601- (1&2)Male Tube (3)Male Pipe FG	(070425)  2601- (1&2)Male Tube (3)Male Pipe FG	(070427)  2602- (1&2)Male Tube (3)Female Pipe FG	(070427)  2602- (1&2)Male Tube (3)Female Pipe FG	
(070401)  2603-Tee (1,2&3)Male Tube FG	(070401)  2603-Tee (1,2&3)Male Tube FG	(070424)  2605- (1&3)Male Tube (2)Male Pipe FG	(070424)  2605- (1&3)Male Tube (2)Male Pipe FG	(070426)  2606- (1&3)Male Tube (2)Female Pipe FG	(070426)  2606- (1&3)Male Tube (2)Female Pipe FG	

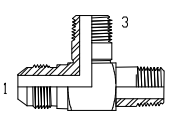
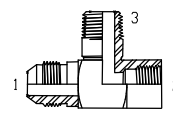
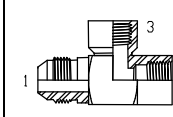
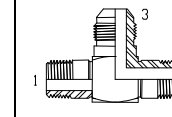
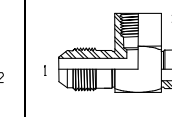
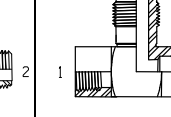
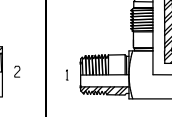
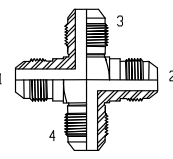
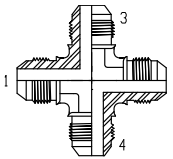
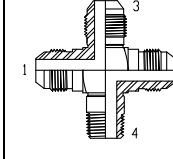
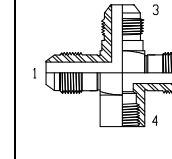
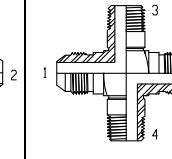
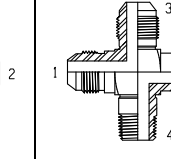
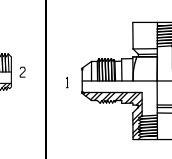
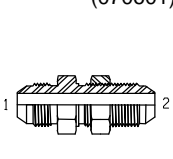
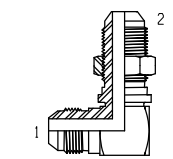
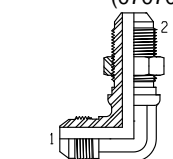
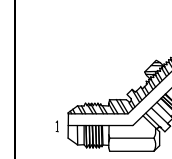
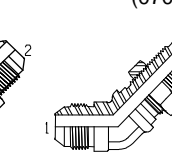
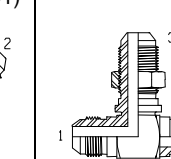
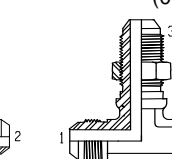
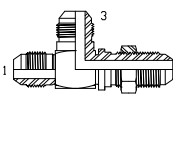
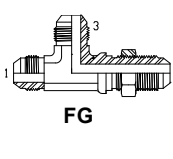
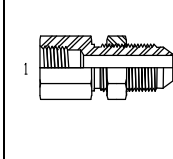
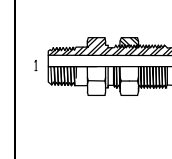
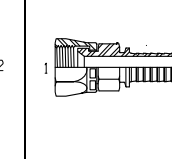
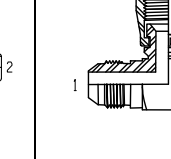
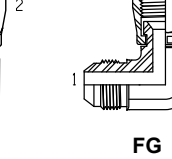
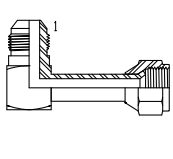
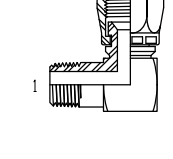
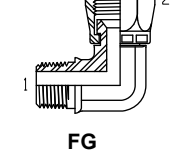
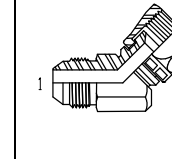
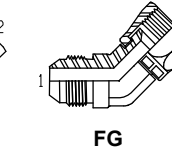
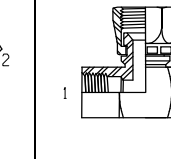
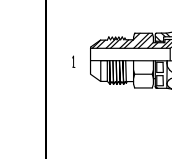
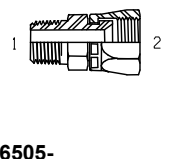
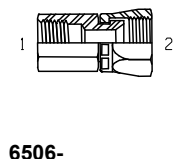
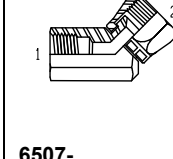
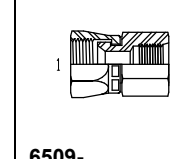
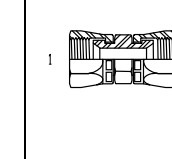
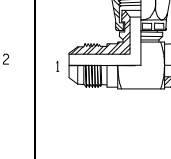
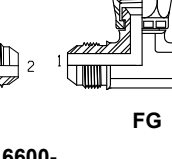
 <p>2607- (1)Male Tube (2&3)Male Pipe</p>	 <p>2608- (1)Male Tube (2)Female Pipe (3)Male Pipe</p>	 <p>2609- (1)Male Tube (2&3)Female Pipe</p>	 <p>2610- (1&2)Male Pipe (3)Male Tube</p>	 <p>2611- (1)Male Tube (2)Male Pipe (3)Female Pipe</p>	 <p>2612- (1&2)Female Tube (3)Male Tube</p>	 <p>2613- (1)Male Pipe (2)Female Pipe (3)Male Tube</p>
 <p>2650- (1,2,3&4)Male Tube</p>	<p>(070501)</p>  <p>FG</p>	 <p>2651- (1,2&3)Male Tube (4)Male Pipe</p>	 <p>2652- (1,2&3)Male Tube (4)Female Pipe</p>	 <p>2653- (1&2)Male Tube (3&4)Male Pipe</p>	 <p>2654- (1&3)Male Tube (2&4)Male Pipe</p>	 <p>2658- (1)Male Tube (2,3&4)Female Pipe</p>
<p>(070601)</p>  <p>2700-LN- (1)Male Tube (2)Bulkhead</p>	 <p>2701-LN- (1)Male Tube (2)Bulkhead</p>	<p>(070701)</p>  <p>FG</p>	 <p>2702-LN- (1)Male Tube (2)Bulkhead</p>	<p>(070801)</p>  <p>FG</p>	 <p>2703-LN- (1&2)Male Tube (3)Bulkhead</p>	<p>(070959)</p>  <p>FG</p>
 <p>2704-LN- (1)Male Tube (2)Bulkhead</p>	<p>(070958)</p>  <p>FG</p>	 <p>2705-LN- (1)Female Pipe (2)Bulkhead</p>	 <p>2706-LN- (1)Male Pipe (2)Bulkhead</p>	 <p>4305- (1)Female Swivel (2)Barbed Hose</p>	 <p>6500- (1)Male Tube (2)37° Female Swivel</p>	<p>(070221)</p>  <p>FG</p>
 <p>6500-L- (1)Male Tube (2)37° Fem. Swivel-Long</p>	 <p>6501- (1)Male Tube (2)37° Female Swivel</p>	 <p>6502- (1)Male Tube (2)37° Female Swivel</p>	<p>(070321)</p>  <p>FG</p>	 <p>6503- (1)Female Pipe (2)37° Female Swivel</p>	 <p>6504- (1)Male Tube (2)37° Female Swivel</p>	<p>(070433)</p>  <p>FG</p>
 <p>6505- (1)Male Pipe (2)37° Female Swivel</p>	 <p>6506- (1)Female Pipe (2)37° Female Swivel</p>	 <p>6507- (1)Female Pipe (2)37° Female Swivel</p>	 <p>6509- (1)37° Female Swivel (2)Female O-Ring</p>	 <p>6565- (1&2)37° Female Swivel</p>	 <p>6600- (1&2)Male Tube (3)37° Female Swivel</p>	<p>(070433)</p>  <p>FG</p>

<p>(070432)</p> <p>6602- (1&3)Male Tube (2)37° Female Swivel</p>	<p>6603- (1&2)37° Female Swivel (3)Male Tube</p>	<p>6604- (1&2)37° Female Swivel (3)Male Pipe</p>	<p>6605- (1&2)37° Female Swivel (3)Female Pipe</p>	<p>6606- (1,2&3) 37° Female Swivel</p>	
---	---	---	---	---	--

0302 SHORT NUT

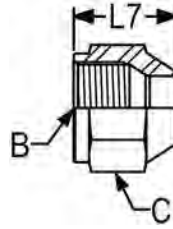

PART NO	TUBE OD	B UN/UNF-2B	L7	C
0302-04	1/4	7/16-20	0.60	0.56
0302-05	5/16	1/2-20	0.59	0.63
0302-06	3/8	9/16-18	0.66	0.69
0302-08	1/2	3/4-16	0.81	0.88
0302-10	5/8	7/8-14	0.94	1.00
0302-12	3/4	1 1/16-12	1.14	1.25
0302-14	7/8	1 3/16-12	1.20	1.38
0302-16	1	1 5/16-12	1.28	1.50
0302-20	1 1/4	1 5/8-12	1.44	2.00
0302-24	1 1/2	1 7/8-12	1.56	2.25
0302-32	2	2 1/2-12	2.00	2.88

0304 STANDARD NUT

SAE J514 070111

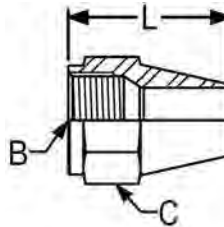

PART NO	TUBE OD	B UN/UNF-2B	L	C
0304-04	1/4	7/16-20	1.00	0.56
0304-05	5/16	1/2-20	1.06	0.63
0304-06	3/8	9/16-18	1.09	0.69
0304-08	1/2	3/4-16	1.28	0.88
0304-10	5/8	7/8-14	1.48	1.00
0304-12	3/4	1 1/16-12	1.66	1.25
0304-14	7/8	1 3/16-12	1.81	1.38
0304-16	1	1 5/16-12	1.94	1.50
0304-20	1 1/4	1 5/8-12	2.19	2.00
0304-24	1 1/2	1 7/8-12	2.31	2.25
0304-32	2	2 1/2-12	2.75	2.88

0304-C CAP NUT

SAE J514 070112

MS51532

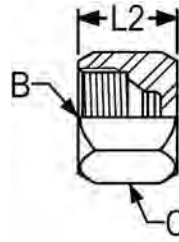

PART NO	TUBE OD	B UN/UNF-2B	L2	C
0304-C-02	1/8	5/16-24	0.50	0.38
0304-C-03	3/16	3/8-24	0.56	0.44
0304-C-04	1/4	7/16-20	0.59	0.56
0304-C-05	5/16	1/2-20	0.60	0.63
0304-C-06	3/8	9/16-18	0.63	0.69
0304-C-08	1/2	3/4-16	0.75	0.88
0304-C-10	5/8	7/8-14	0.84	1.00
0304-C-12	3/4	1 1/16-12	0.91	1.25
0304-C-14	7/8	1 3/16-12	0.97	1.38
0304-C-16	1	1 5/16-12	1.02	1.50
0304-C-20	1 1/4	1 5/8-12	1.06	2.00
0304-C-24	1 1/2	1 7/8-12	1.19	2.25
0304-C-32	2	2 1/2-12	1.44	2.88

0306 BULKHEAD LOCK NUT

SAE J514 070118

MS51860

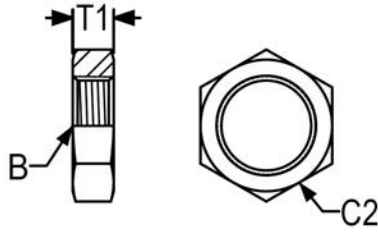

PART NO	TUBE OD	B UN/UNF-2B	T1	C2
0306-02	1/8	5/16-24	0.22	0.56
0306-04	1/4	7/16-20	0.28	0.69
0306-05	5/16	1/2-20	0.28	0.75
0306-06	3/8	9/16-18	0.27	0.81
0306-08	1/2	3/4-16	0.31	1.00
0306-10	5/8	7/8-14	0.36	1.13
0306-12	3/4	1 1/16-12	0.41	1.38
0306-14	7/8	1 3/16-12	0.41	1.50
0306-16	1	1 5/16-12	0.41	1.63
0306-20	1 1/4	1 5/8-12	0.41	1.88
0306-24	1 1/2	1 7/8-12	0.41	2.13
0306-32	2	2 1/2-12	0.41	2.75

0306-N ADJUSTABLE LOCK NUT

SAE J514 070117

MS51888

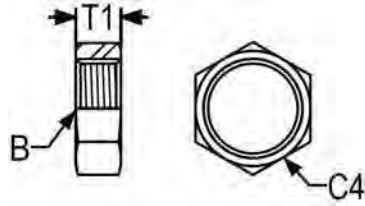

PART NO	TUBE OD	B UN/UNF-2B	T1	C4
0306-N-03	3/16	3/8-24	0.22	0.50
0306-N-04	1/4	7/16-20	0.25	0.56
0306-N-05	5/16	1/2-20	0.25	0.63
0306-N-06	3/8	9/16-18	0.27	0.69
0306-N-08	1/2	3/4-16	0.34	0.88
0306-N-10	5/8	7/8-14	0.39	1.00
0306-N-12	3/4	1 1/16-12	0.41	1.25
0306-N-14	7/8	1 3/16-12	0.41	1.38
0306-N-16	1	1 5/16-12	0.41	1.50

0318 TUBE NUT

SAE J514 070110

MS51531

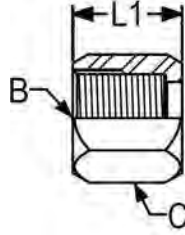

PART NO	TUBE OD	B UN/UNF-2B	L1	C
0318-02	1/8	5/16-24	0.54	0.38
0318-03	3/16	3/8-24	0.60	0.44
0318-04	1/4	7/16-20	0.61	0.56
0318-05	5/16	1/2-20	0.67	0.63
0318-06	3/8	9/16-18	0.72	0.69
0318-08	1/2	3/4-16	0.84	0.88
0318-10	5/8	7/8-14	0.97	1.00
0318-12	3/4	1 1/16-12	1.02	1.25
0318-14	7/8	1 3/16-12	1.08	1.38
0318-16	1	1 5/16-12	1.12	1.50
0318-20	1 1/4	1 5/8-12	1.22	2.00
0318-24	1 1/2	1 7/8-12	1.42	2.25
0318-32	2	2 1/2-12	1.74	2.88
0318-40	2 1/2	3-12	1.63	3.50

0319 TUBE
SLEEVE SAE J514
 070115 MS51533

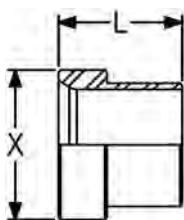

PART NO	TUBE OD	L	X
0319-02	1/8	0.34	0.27
0319-03	3/16	0.34	0.33
0319-04	1/4	0.41	0.38
0319-05	5/16	0.44	0.44
0319-06	3/8	0.50	0.50
0319-08	1/2	0.56	0.68
0319-10	5/8	0.66	0.80
0319-12	3/4	0.68	0.97
0319-14	7/8	0.76	1.10
0319-16	1	0.78	1.22
0319-20	1 1/4	0.91	1.53
0319-24	1 1/2	1.12	1.78
0319-32	2	1.19	2.41

2403 MALE TUBE UNION

SAE J514 070101
MS51501

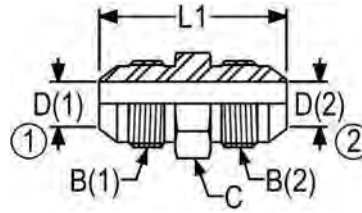

PART NO	TUBE OD	B (1) UN/UNF-2A	B (2) UN/UNF-2A	L1	C	D (1)	D (2)
2403-02-02	1/8-1/8	5/16-24	5/16-24	1.17	0.44	0.06	0.06
2403-03-03	3/16-3/16	3/8-24	3/8-24	1.23	0.44	0.13	0.13
2403-04-02	1/4-1/8	7/16-20	5/16-24	1.27	0.50	0.17	0.06
2403-040-3	1/4-3/16	7/16-20	3/8-24	1.30	0.50	0.17	0.13
2403-04-04	1/4-1/4	7/16-20	7/16-20	1.37	0.50	0.17	0.17
2403-05-04	5/16-1/4	1/2-20	7/16-20	1.37	0.56	0.23	0.17
2403-05-05	5/16-5/16	1/2-20	1/2-20	1.37	0.56	0.23	0.23
2403-06-04	3/8-1/4	9/16-18	7/16-20	1.40	0.63	0.30	0.17
2403-06-05	3/8-5/16	9/16-18	1/2-20	1.40	0.63	0.30	0.23
2403-06-06	3/8-3/8	9/16-18	9/16-18	1.41	0.63	0.30	0.30
2403-08-04	1/2-1/4	3/4-16	7/16-20	1.51	0.81	0.39	0.17
2403-08-06	1/2-3/8	3/4-16	9/16-18	1.52	0.81	0.39	0.30
2403-08-08	1/2-1/2	3/4-16	3/4-16	1.62	0.81	0.39	0.39
2403-10-06	5/8-3/8	7/8-14	9/16-18	1.68	0.94	0.48	0.30
2403-10-08	5/8-1/2	7/8-14	3/4-16	1.78	0.94	0.48	0.39
2403-10-10	5/8-5/8	7/8-14	7/8-14	1.88	0.94	0.48	0.48
2403-12-04	3/4-1/4	1 1/16-12	7/16-20	1.85	1.13	0.61	0.17
2403-12-06	3/4-3/8	1 1/16-12	9/16-18	1.85	1.13	0.61	0.30
2403-12-08	3/4-1/2	1 1/16-12	3/4-16	1.95	1.13	0.61	0.39
2403-12-10	3/4-5/8	1 1/16-12	7/8-14	2.05	1.13	0.61	0.48
2403-12-12	3/4-3/4	1 1/16-12	1 1/16-12	2.16	1.13	0.61	0.61
2403-14-12	7/8-3/4	1 3/16-12	1 1/16-12	2.18	1.25	0.72	0.61
2403-14-14	7/8-7/8	1 3/16-12	1 3/16-12	2.21	1.25	0.72	0.72
2403-16-08	1-1/2	1 5/16-12	3/4-16	2.00	1.38	0.84	0.39
2403-16-12	1-3/4	1 5/16-12	1 1/16-12	2.20	1.38	0.84	0.61
2403-16-16	1-1	1 5/16-12	1 5/16-12	2.25	1.38	0.84	0.84
2403-20-12	1 1/4-3/4	1 5/8-12	1 1/16-12	2.34	1.69	1.08	0.61
2403-20-16	1 1/4-1	1 5/8-12	1 5/16-12	2.38	1.69	1.08	0.84
2403-20-20	1 1/4-1 1/4	1 5/8-12	1 5/8-12	2.43	1.69	1.08	1.08
2403-24-12	1 1/2-3/4	1 7/8-12	1 1/16-12	2.53	2.00	1.31	0.61
2403-24-16	1 1/2-1	1 7/8-12	1 5/16-12	2.58	2.00	1.31	0.84
2403-24-20	1 1/2-1 1/4	1 7/8-12	1 5/8-12	2.62	2.00	1.31	1.08
2403-24-24	1 1/2-1 1/2	1 7/8-12	1 7/8-12	2.75	2.00	1.31	1.31
2403-32-16	2-1	2 1/2-12	1 5/16-12	2.98	2.63	1.78	0.84
2403-32-20	2-1 1/4	2 1/2-12	1 5/8-12	3.02	2.63	1.78	1.08
2403-32-24	2-1 1/2	2 1/2-12	1 7/8-12	3.15	2.63	1.78	1.31
2403-32-32	2-2	2 1/2-12	2 1/2-12	3.40	2.63	1.78	1.78

2403-LH LARGE HEX UNION

SAE J514 070119

MS51519

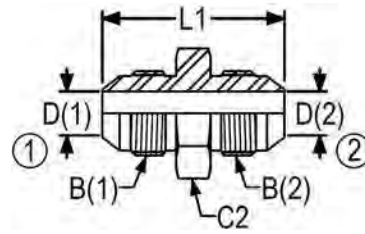

PART NO	TUBE OD	B (1) UN/UNF-2A	B (2) UN/UNF-2A	L1	C2	D (1)	D (2)
2403-LH-04-04	1/4-1/4	7/16-20	7/16-20	1.37	0.69	0.17	0.17
2403-LH-05-05	5/16-5/16	1/2-20	1/2-20	1.37	0.75	0.23	0.23
2403-LH-06-06	3/8-3/8	9/16-18	9/16-18	1.41	0.81	0.30	0.30
2403-LH-08-04	1/2-1/4	3/4-16	7/16-20	1.51	1.00	0.39	0.17
2403-LH-08-06	1/2-3/8	3/4-16	9/16-18	1.52	1.00	0.39	0.30
2403-LH-08-08	1/2-1/2	3/4-16	3/4-16	1.62	1.00	0.39	0.39
2403-LH-10-08	5/8-1/2	7/8-14	3/4-16	1.78	1.13	0.48	0.39
2403-LH-10-10	5/8-5/8	7/8-14	7/8-14	1.88	1.13	0.48	0.48
2403-LH-12-08	3/4-1/2	1 1/16-12	3/4-16	1.95	1.38	0.61	0.39
2403-LH-12-10	3/4-5/8	1 1/16-12	7/8-14	2.05	1.38	0.61	0.48
2403-LH-12-12	3/4-3/4	1 1/16-12	1 1/16-12	2.16	1.38	0.61	0.61
2403-LH-16-16	1-1	1 5/16-12	1 5/16-12	2.25	1.63	0.84	0.84
2403-LH-20-20	1 1/4-1 1/4	1 5/8-12	1 5/8-12	2.43	1.88	1.08	1.08
2403-LH-24-24	1 1/2-1 1/2	1 7/8-12	1 7/8-12	2.75	2.13	1.31	1.31

2404 MALE CONNECTOR

SAE J514 070102

MS51500

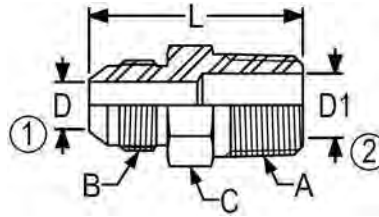

PART NO	TUBE OD	B UN/UNF-2A	A NPTF	L	C	D	D1
2404-02-02	1/8	5/16-24	1/8-27	1.11	0.44	0.06	0.19
2404-02-08	1/8	5/16-24	1/2-14	1.58	0.88	0.06	0.53
2404-03-02	3/16	3/8-24	1/8-27	1.14	0.44	0.13	0.19
2404-04-02	1/4	7/16-20	1/8-27	1.22	0.50	0.17	0.19
2404-04-04	1/4	7/16-20	1/4-18	1.42	0.56	0.17	0.28
2404-04-06	1/4	7/16-20	3/8-18	1.42	0.75	0.17	0.41
2404-04-08	1/4	7/16-20	1/2-14	1.68	0.88	0.17	0.53
2404-04-12	1/4	7/16-20	3/4-14	1.75	1.13	0.17	0.72
2404-05-02	5/16	1/2-20	1/8-27	1.22	0.56	0.23	0.19
2404-05-04	5/16	1/2-20	1/4-18	1.42	0.56	0.23	0.28
2404-05-06	5/16	1/2-20	3/8-18	1.42	0.75	0.23	0.41
2404-06-02	3/8	9/16-18	1/8-27	1.24	0.63	0.30	0.19
2404-06-04	3/8	9/16-18	1/4-18	1.43	0.63	0.30	0.28
2404-06-06	3/8	9/16-18	3/8-18	1.43	0.75	0.30	0.41
2404-06-08	3/8	9/16-18	1/2-14	1.69	0.88	0.30	0.53
2404-06-12	3/8	9/16-18	3/4-14	1.75	1.13	0.30	0.72
2404-06-16	3/8	9/16-18	1-11 1/2	1.94	1.38	0.30	0.94
2404-08-04	1/2	3/4-16	1/4-18	1.53	0.81	0.39	0.28
2404-08-06	1/2	3/4-16	3/8-18	1.53	0.81	0.39	0.41
2404-08-08	1/2	3/4-16	1/2-14	1.79	0.88	0.39	0.53
2404-08-12	1/2	3/4-16	3/4-14	1.85	1.13	0.39	0.72
2404-08-16	1/2	3/4-16	1-11 1/2	2.05	1.38	0.39	0.94
2404-10-04	5/8	7/8-14	1/4-18	1.70	0.94	0.48	0.28
2404-10-06	5/8	7/8-14	3/8-18	1.70	0.94	0.48	0.41
2404-10-08	5/8	7/8-14	1/2-14	1.89	0.94	0.48	0.53
2404-10-12	5/8	7/8-14	3/4-14	1.95	1.13	0.48	0.72
2404-10-16	5/8	7/8-14	1-11 1/2	2.15	1.38	0.48	0.94
2404-12-06	3/4	1 1/16-12	3/8-18	1.87	1.13	0.61	0.41
2404-12-08	3/4	1 1/16-12	1/2-14	2.06	1.13	0.61	0.53
2404-12-12	3/4	1 1/16-12	3/4-14	2.06	1.13	0.61	0.72
2404-12-16	3/4	1 1/16-12	1-11 1/2	2.25	1.38	0.61	0.94
2404-12-20	3/4	1 1/16-12	1 1/4-11 1/2	2.36	1.69	0.61	1.25
2404-12-24	3/4	1 1/16-12	1 1/2-11 1/2	2.46	2.00	0.61	1.50
2404-14-08	7/8	1 3/16-12	1/2-14	2.09	1.25	0.72	0.53
2404-14-12	7/8	1 3/16-12	3/4-14	2.09	1.25	0.72	0.72
2404-16-08	1	1 5/16-12	1/2-14	2.11	1.38	0.84	0.53

2404 MALE CONNECTOR (Con't)

SAE J514 070102
MS51500

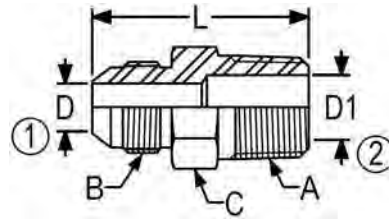

PART NO	TUBE OD	B UN/UNF-2A	A NPTF	L	C	D	D1
2404-16-12	1	1 5/16-12	3/4-14	2.11	1.38	0.84	0.72
2404-16-16	1	1 5/16-12	1-11 1/2	2.30	1.38	0.84	0.94
2404-16-20	1	1 5/16-12	1 1/4-11 1/2	2.40	1.69	0.84	1.25
2404-16-24	1	1 5/16-12	1 1/2-11 1/2	2.51	2.00	0.84	1.50
2404-20-12	1 1/4	1 5/8-12	3/4-14	2.23	1.69	1.08	0.72
2404-20-16	1 1/4	1 5/8-12	1-11 1/2	2.42	1.69	1.08	0.94
2404-20-20	1 1/4	1 5/8-12	1 1/4-11 1/2	2.45	1.69	1.08	1.25
2404-20-24	1 1/4	1 5/8-12	1 1/2-11 1/2	2.55	2.00	1.08	1.50
2404-20-32	1 1/4	1 5/8-12	2-11 1/2	2.73	2.50	1.08	1.94
2404-24-12	1 1/2	1 7/8-12	3/4-14	2.43	2.00	1.32	0.72
2404-24-16	1 1/2	1 7/8-12	1-11 1/2	2.62	2.00	1.31	0.94
2404-24-20	1 1/2	1 7/8-12	1 1/4-11 1/2	2.65	2.00	1.31	1.25
2404-24-24	1 1/2	1 7/8-12	1 1/2-11 1/2	2.68	2.00	1.31	1.50
2404-24-32	1 1/2	1 7/8-12	2-11 1/2	2.86	2.63	1.31	1.94
2404-32-16	2	2 1/2-12	1-11 1/2	3.02	2.63	1.78	0.94
2404-32-20	2	2 1/2-12	1 1/4-11 1/2	3.05	2.63	1.78	1.25
2404-32-24	2	2 1/2-12	1 1/2-11 1/2	3.08	2.63	1.78	1.50
2404-32-32	2	2 1/2-12	2-11 1/2	3.11	2.63	1.78	1.94

2404-L MALE LONG CONNECTOR

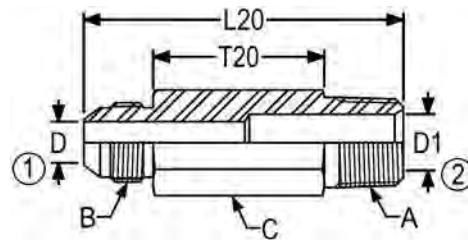

PART NO	TUBE OD	B UN/UNF-2A	A NPTF	L20	T20 REF.	C	D	D1
2404-L-04-02	1/4	7/16-20	1/8-27	1.81	0.88	0.50	0.17	0.19
2404-L-04-04	1/4	7/16-20	1/4-18	2.25	1.14	0.56	0.17	0.28
2404-L-05-04	5/16	1/2-20	1/4-18	2.25	1.14	0.56	0.23	0.28
2404-L-06-04	3/8	9/16-18	1/4-18	2.25	1.13	0.63	0.30	0.28
2404-L-06-06	3/8	9/16-18	3/8-18	2.50	1.38	0.75	0.30	0.41
2404-L-08-06	1/2	3/4-16	3/8-18	2.75	1.53	0.81	0.39	0.41
2404-L-08-08	1/2	3/4-16	1/2-14	3.03	1.63	0.88	0.39	0.53
2404-L-10-08	5/8	7/8-14	1/2-14	3.13	1.62	0.94	0.48	0.53
2404-L-12-12	3/4	1 1/16-12	3/4-14	3.50	1.89	1.13	0.61	0.72
2404-L-16-16	1	1 5/16-12	1-11 1/2	4.00	2.15	1.38	0.84	0.94
2404-L-20-20	1 1/4	1 5/8-12	1 1/4-11 1/2	4.50	2.57	1.69	1.08	1.25

2404-LL MALE EXTRA LONG CONNECTOR

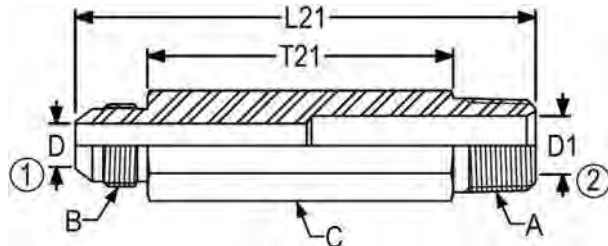

PART NO	TUBE OD	B UN/UNF-2A	A NPTF	L21	T21 REF.	C	D	D1
2404-LL-04-02	1/4	7/16-20	1/8-27	2.56	1.63	0.50	0.17	0.19
2404-LL-04-04	1/4	7/16-20	1/4-18	3.25	2.14	0.56	0.17	0.28
2404-LL-05-02	5/16	1/2-20	1/8-27	2.81	1.88	0.56	0.23	0.19
2404-LL-06-04	3/8	9/16-18	1/4-18	3.25	2.13	0.63	0.30	0.28
2404-LL-06-06	3/8	9/16-18	3/8-18	3.50	2.37	0.75	0.30	0.41
2404-LL-08-06	1/2	3/4-16	3/8-18	4.00	2.78	0.81	0.39	0.41
2404-LL-08-08	1/2	3/4-16	1/2-14	4.19	2.78	0.88	0.39	0.53
2404-LL-10-08	5/8	7/8-14	1/2-14	4.38	2.87	0.94	0.48	0.53
2404-LL-12-12	3/4	1 1/16-12	3/4-14	5.00	3.39	1.13	0.61	0.72
2404-LL-16-16	1	1 5/16-12	1-11 1/2	5.75	3.90	1.38	0.84	0.94

2404-LLL MALE EXTRA EXTRA LONG CONNECTOR

INFORMATION AVAILABLE UPON REQUEST.
CALL CUSTOMER SERVICE FOR DETAILS.

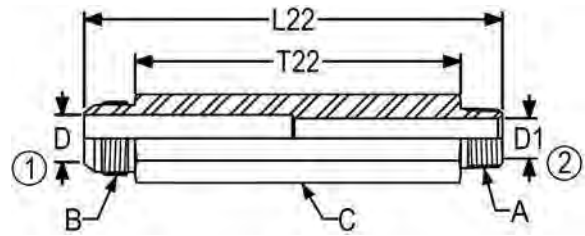

2405 FEMALE CONNECTOR

SAE J514 070103

MS51503

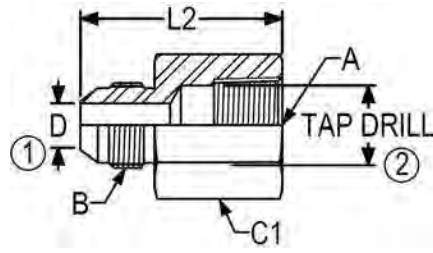

PART NO	TUBE OD	B UN/UNF-2A	A NPTF	L2	C1	D	TAP DRILL
2405-02-02	1/8	5/16-24	1/8-27	1.12	0.56	0.06	0.33
2405-03-04	3/16	3/8-24	1/4-18	1.32	0.75	0.13	0.43
2405-04-02	1/4	7/16-20	1/8-27	1.19	0.56	0.17	0.33
2405-04-04	1/4	7/16-20	1/4-18	1.39	0.75	0.17	0.43
2405-04-06	1/4	7/16-20	3/8-18	1.45	0.88	0.17	0.57
2405-04-08	1/4	7/16-20	1/2-14	1.68	1.13	0.17	0.70
2405-05-02	5/16	1/2-20	1/8-27	1.17	0.56	0.23	0.33
2405-05-04	5/16	1/2-20	1/4-18	1.39	0.75	0.23	0.43
2405-05-06	5/16	1/2-20	3/8-18	1.45	0.88	0.23	0.57
2405-06-02	3/8	9/16-18	1/8-27	1.19	0.63	0.30	0.33
2405-06-04	3/8	9/16-18	1/4-18	1.40	0.75	0.30	0.43
2405-06-06	3/8	9/16-18	3/8-18	1.46	0.88	0.30	0.57
2405-06-08	3/8	9/16-18	1/2-14	1.69	1.13	0.30	0.70
2405-08-04	1/2	3/4-16	1/4-18	1.55	0.81	0.39	0.43
2405-08-06	1/2	3/4-16	3/8-18	1.56	0.88	0.39	0.57
2405-08-08	1/2	3/4-16	1/2-14	1.79	1.13	0.39	0.70
2405-08-12	1/2	3/4-16	3/4-14	1.85	1.38	0.39	0.91
2405-10-04	5/8	7/8-14	1/4-18	1.66	0.94	0.48	0.43
2405-10-06	5/8	7/8-14	3/8-18	1.50	0.94	0.48	0.57
2405-10-08	5/8	7/8-14	1/2-14	1.89	1.13	0.48	0.70
2405-10-12	5/8	7/8-14	3/4-14	1.95	1.38	0.48	0.91
2405-12-08	3/4	1 1/16-12	1/2-14	2.05	1.13	0.61	0.70
2405-12-12	3/4	1 1/16-12	3/4-14	2.06	1.38	0.61	0.91
2405-12-16	3/4	1 1/16-12	1-11 1/2	2.30	1.63	0.61	1.14
2405-14-12	7/8	1 3/16-12	3/4-14	2.06	1.38	0.72	0.91
2405-16-12	1	1 5/16-12	3/4-14	2.12	1.38	0.84	0.91
2405-16-16	1	1 5/16-12	1-11 1/2	2.35	1.63	0.84	1.14
2405-16-20	1	1 5/16-12	1 1/4-11 1/2	2.44	2.00	0.84	1.48
2405-20-16	1 1/4	1 5/8-12	1-11 1/2	2.47	1.69	1.08	1.14
2405-20-20	1 1/4	1 5/8-12	1 1/4-11 1/2	2.49	2.00	1.08	1.48
2405-20-24	1 1/4	1 5/8-12	1 1/2-11 1/2	2.49	2.38	1.08	1.72
2405-24-20	1 1/2	1 7/8-12	1 1/4-11 1/2	2.62	2.00	1.31	1.48
2405-24-24	1 1/2	1 7/8-12	1 1/2-11 1/2	2.62	2.38	1.31	1.72
2405-32-24	2	2 1/2-12	1 1/2-11 1/2	2.05	2.63	1.72	1.72
2405-32-32	2	2 1/2-12	2-11 1/2	2.97	2.88	1.78	2.19

2406 REDUCING ADAPTER (ONE PIECE)

MS39323

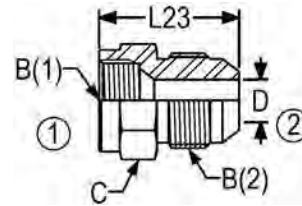

PART NO	TUBE OD	B (1) UN/UNF-2B	B (2) UN/UNF-2A	L23	C	D
2406-04-06	1/4-3/8	7/16-20	9/16-18	1.00	0.63	0.17
2406-05-04	5/16-1/4	1/2-20	7/16-20	1.19	0.63	0.17
2406-05-06	5/16-3/8	1/2-20	9/16-18	1.19	0.63	0.30
2406-05-08	5/16-1/2	1/2-20	3/4-16	1.16	0.81	0.39
2406-06-04	3/8-1/4	9/16-18	7/16-20	1.19	0.69	0.17
2406-06-05	3/8-5/16	9/16-18	1/2-20	1.19	0.69	0.23
2406-06-06	3/8-3/8	9/16-18	9/16-18	1.13	0.69	0.30
2406-06-08	3/8-1/2	9/16-18	3/4-16	1.16	0.81	0.30
2406-08-04	1/2-1/4	3/4-16	7/16-20	1.33	0.88	0.17
2406-08-05	1/2-5/16	3/4-16	1/2-20	1.33	0.88	0.23
2406-08-06	1/2-3/8	3/4-16	9/16-18	1.33	0.88	0.30
2406-08-10	1/2-5/8	3/4-16	7/8-14	1.29	0.94	0.39
2406-08-12	1/2-3/4	3/4-16	1 1/16-12	1.44	1.13	0.39
2406-08-16	1/2-1	3/4-16	1 5/16-12	1.61	1.38	0.39
2406-10-04	5/8-1/4	7/8-14	7/16-20	1.47	1.00	0.17
2406-10-06	5/8-3/8	7/8-14	9/16-18	1.41	1.00	0.30
2406-10-08	5/8-1/2	7/8-14	3/4-16	1.41	1.00	0.39
2406-10-12	5/8-3/4	7/8-14	1 1/16-12	1.49	1.13	0.48
2406-12-04	3/4-1/4	1 1/16-12	7/16-20	1.50	1.25	0.17
2406-12-06	3/4-3/8	1 1/16-12	9/16-18	1.46	1.25	0.30
2406-12-08	3/4-1/2	1 1/16-12	3/4-16	1.56	1.25	0.39
2406-12-10	3/4-5/8	1 1/16-12	7/8-14	1.64	1.25	0.48
2406-12-12	3/4-3/4	1 1/16-12	1 1/16-12	1.56	1.25	0.61
2406-12-16	3/4-1	1 1/16-12	1 5/16-12	1.61	1.38	0.61
2406-14-06	7/8-3/8	1 3/16-12	9/16-18	1.59	1.38	0.30
2406-14-08	7/8-1/2	1 3/16-12	3/4-16	1.69	1.38	0.39
2406-14-10	7/8-5/8	1 3/16-12	7/8-14	1.73	1.38	0.48
2406-14-12	7/8-3/4	1 3/16-12	1 1/16-12	1.80	1.38	0.61
2406-16-04	1-1/4	1 5/16-12	7/16-20	1.67	1.50	0.17
2406-16-06	1-3/8	1 5/16-12	9/16-18	1.65	1.50	0.30
2406-16-08	1-1/2	1 5/16-12	3/4-16	1.72	1.50	0.39
2406-16-10	1-5/8	1 5/16-12	7/8-14	1.79	1.50	0.48
2406-16-12	1-3/4	1 5/16-12	1 1/16-12	1.82	1.50	0.61
2406-16-14	1-7/8	1 5/16-12	1 3/16-12	1.86	1.50	0.72
2406-16-20	1-1 1/4	1 5/16-12	1 5/8-12	1.71	1.69	0.84

2406 REDUCING ADAPTER (ONE PIECE)

(Con't)

MS39323

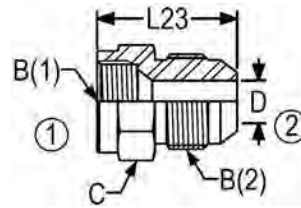

PART NO	TUBE OD	B (1) UN/UNF-2B	B (2) UN/UNF-2A	L23	C	D
2406-16-24	1-1 1/2	1 5/16-12	1 7/8-12	1.81	2.00	0.84
2406-20-06	1 1/4-3/8	1 5/8-12	9/16-18	1.77	2.00	0.30
2406-20-08	1 1/4-1/2	1 5/8-12	3/4-16	1.84	2.00	0.39
2406-20-10	1 1/4-5/8	1 5/8-12	7/8-14	1.91	2.00	0.48
2406-20-12	1 1/4-3/4	1 5/8-12	1 1/16-12	2.02	2.00	0.61
2406-20-14	1 1/4-7/8	1 5/8-12	1 3/16-12	2.03	2.00	0.72
2406-20-16	1 1/4-1	1 5/8-12	1 5/16-12	2.01	2.00	0.84
2406-20-24	1 1/4-1 1/2	1 5/8-12	1 7/8-12	2.14	2.00	1.08
2406-24-08	1 1/2-1/2	1 7/8-12	3/4-16	2.09	2.25	0.39
2406-24-10	1 1/2-5/8	1 7/8-12	7/8-14	2.19	2.25	0.48
2406-24-12	1 1/2-3/4	1 7/8-12	1 1/16-12	2.19	2.25	0.61
2406-24-16	1 1/2-1	1 7/8-12	1 5/16-12	2.22	2.25	0.84
2406-24-20	1 1/2-1 1/4	1 7/8-12	1 5/8-12	2.14	2.25	1.08
2406-24-32	1 1/2-2	1 7/8-12	2 1/2-12	2.14	2.63	1.31
2406-32-08	2-1/2	2 1/2-12	3/4-16	2.10	2.88	0.39
2406-32-12	2-3/4	2 1/2-12	1 1/16-12	2.31	2.88	0.61
2406-32-16	2-1	2 1/2-12	1 5/16-12	2.58	2.88	0.84
2406-32-20	2-1 1/4	2 1/2-12	1 5/8-12	2.58	2.88	1.08
2406-32-24	2-1 1/2	2 1/2-12	1 7/8-12	2.61	2.88	1.31

2407 REDUCING ADAPTER

SAE J514 070123

MS51534 / MS39323

AVAILABLE WITH OR WITHOUT NUT. CALL CUSTOMER SERVICE FOR AVAILABILITY.

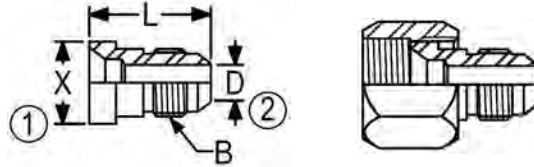

PART NO	TUBE OD	B UN/UNF-2A	L	X	D
2407-06-04	3/8-1/4	7/16-20	0.97	0.50	0.17
2407-08-04	1/2-1/4	7/16-20	1.00	0.68	0.17
2407-08-06	1/2-3/8	9/16-18	1.00	0.68	0.30
2407-10-04	5/8-1/4	7/16-20	1.03	0.80	0.17
2407-10-06	5/8-3/8	9/16-18	1.03	0.80	0.30
2407-12-04	3/4-1/4	7/16-20	1.09	0.97	0.17
2407-12-06	3/4-3/8	9/16-18	1.09	0.97	0.30
2407-12-08	3/4-1/2	3/4-16	1.19	0.97	0.39
2407-16-04	1-1/4	7/16-20	1.16	1.22	0.17
2407-16-06	1-3/8	9/16-18	1.16	1.22	0.30
2407-16-08	1-1/2	3/4-16	1.28	1.22	0.39
2407-16-10	1-5/8	7/8-14	1.37	1.22	0.48
2407-16-12	1-3/4	1 1/16-12	1.47	1.22	0.61
2407-20-12	1 1/4-3/4	1 1/16-12	1.50	1.53	0.61
2407-20-16	1 1/4-1	1 5/16-12	1.55	1.53	0.84

2408 MALE TUBE PLUG

SAE J514 070109

MS51518

AVAILABLE WITH OR WITHOUT HOLE. CALL CUSTOMER SERVICE FOR AVAILABILITY.

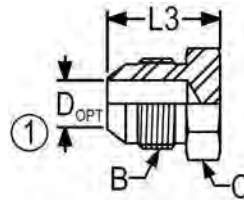

PART NO	TUBE OD	B UN/UNF-2A	L3	C	D (OPT)
2408-02	1/8	5/16-24	0.70	0.44	0.06
2408-03	3/16	3/8-24	0.73	0.44	0.13
2408-04	1/4	7/16-20	0.80	0.50	0.17
2408-05	5/16	1/2-20	0.80	0.56	0.23
2408-06	3/8	9/16-18	0.84	0.63	0.30
2408-08	1/2	3/4-16	0.94	0.81	0.39
2408-10	5/8	7/8-14	1.10	0.94	0.48
2408-12	3/4	1 1/16-12	1.28	1.13	0.61
2408-14	7/8	1 3/16-12	1.31	1.25	0.72
2408-16	1	1 5/16-12	1.33	1.38	0.84
2408-20	1 1/4	1 5/8-12	1.45	1.69	1.08
2408-24	1 1/2	1 7/8-12	1.65	2.00	1.31
2408-32	2	2 1/2-12	2.05	2.63	1.78

2500 90 DEGREE UNION ELBOW

SAE J514 070201
MS51505

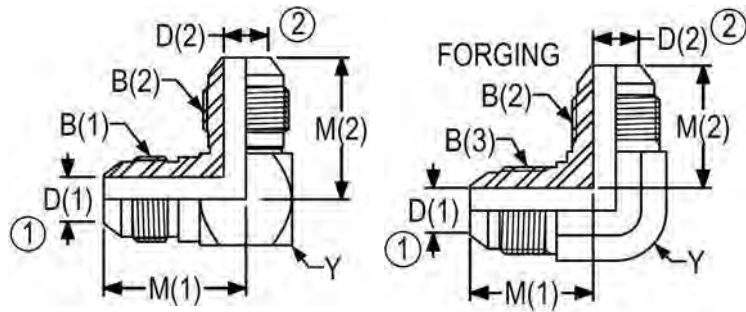

*Non forging parts are brazed construction

PART NO	TUBE OD	B (1) UN/UNF-2A	B (2) UN/UNF-2A	M (1)	M (2)	Y	D (1)	D (2)
2500-04-04	1/4-1/4	7/16-20	7/16-20	0.89	0.89	0.50	0.17	0.17
2500-04-04-FG	1/4-1/4	7/16-20	7/16-20	0.89	0.89	0.44	0.17	0.17
2500-05-04	5/16-1/4	1/2-20	7/16-20	0.95	0.92	0.56	0.23	0.17
2500-05-05	5/16-5/16	1/2-20	1/2-20	0.95	0.95	0.56	0.23	0.23
2500-05-05-FG	5/16-5/16	1/2-20	1/2-20	0.95	0.95	0.56	0.23	0.23
2500-06-04	3/8-1/4	9/16-18	7/16-20	1.06	0.95	0.63	0.30	0.17
2500-06-05	3/8-5/16	9/16-18	1/2-20	1.06	0.98	0.63	0.30	0.23
2500-06-06	3/8-3/8	9/16-18	9/16-18	1.06	1.06	0.63	0.30	0.30
2500-06-06-FG	3/8-3/8	9/16-18	9/16-18	1.06	1.06	0.56	0.30	0.30
2500-08-06	1/2-3/8	3/4-16	9/16-18	1.25	1.15	0.81	0.39	0.30
2500-08-08	1/2-1/2	3/4-16	3/4-16	1.25	1.25	0.81	0.39	0.39
2500-08-08-FG	1/2-1/2	3/4-16	3/4-16	1.25	1.25	0.75	0.39	0.39
2500-10-06	5/8-3/8	7/8-14	9/16-18	1.45	1.22	0.94	0.48	0.30
2500-10-08	5/8-1/2	7/8-14	3/4-16	1.45	1.31	0.94	0.48	0.39
2500-10-08-FG	5/8-1/2	7/8-14	3/4-16	1.45	1.33	0.88	0.48	0.39
2500-10-10	5/8-5/8	7/8-14	7/8-14	1.45	1.45	0.94	0.48	0.48
2500-10-10-FG	5/8-5/8	7/8-14	7/8-14	1.45	1.45	0.88	0.48	0.48
2500-12-08	3/4-1/2	1 1/16-12	3/4-16	1.66	1.40	1.13	0.61	0.39
2500-12-10	3/4-5/8	1 1/16-12	7/8-14	1.66	1.55	1.13	0.61	0.48
2500-12-12	3/4-3/4	1 1/16-12	1 1/16-12	1.66	1.66	1.13	0.61	0.61
2500-12-12-FG	3/4-3/4	1 1/16-12	1 1/16-12	1.66	1.66	1.06	0.61	0.61
2500-14-14	7/8-7/8	1 3/16-12	1 3/16-12	1.80	1.80	1.25	0.72	0.72
2500-16-12	1-3/4	1 5/16-12	1 1/16-12	1.81	1.78	1.38	0.84	0.61
2500-16-12-FG	1-3/4	1 5/16-12	1 1/16-12	1.81	1.76	1.31	0.84	0.61
2500-16-16	1-1	1 5/16-12	1 5/16-12	1.81	1.81	1.38	0.84	0.84
2500-16-16-FG	1-1	1 5/16-12	1 5/16-12	1.81	1.81	1.31	0.84	0.84
2500-20-16	1 1/4-1	1 5/8-12	1 5/16-12	2.06	2.00	1.75	1.08	0.84
2500-20-20	1 1/4-1 1/4	1 5/8-12	1 5/8-12	2.06	2.06	1.75	1.08	1.08
2500-20-20-FG	1 1/4-1 1/4	1 5/8-12	1 5/8-12	2.06	2.06	1.63	1.08	1.08
2500-24-24	1 1/2-1 1/2	1 7/8-12	1 7/8-12	2.33	2.33	2.00	1.31	1.31
2500-24-24-FG	1 1/2-1 1/2	1 7/8-12	1 7/8-12	2.33	2.33	1.88	1.31	1.31
2500-32-32	2-2	2 1/2-12	2 1/2-12	3.06	3.06	2.63	1.78	1.78
2500-32-32-FG	2-2	2 1/2-12	2 1/2-12	3.06	3.06	2.50	1.78	1.78

2501 90 DEGREE MALE ELBOW

SAE J514 070202
MS51504

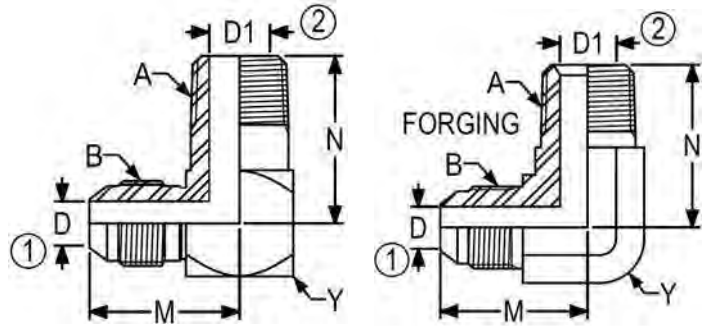

*Non forging parts are brazed construction

PART NO	TUBE OD	B UN/UNF-2A	A NPTF	M	N	Y	D	D1
2501-02-02	1/8	5/16-24	1/8-27	0.81	0.78	0.50	0.06	0.19
2501-02-02-FG	1/8	5/16-24	1/8-27	0.77	0.72	0.44	0.06	0.19
2501-02-04	1/8	5/16-24	1/4-18	0.87	1.09	0.63	0.06	0.28
2501-03-02	3/16	3/8-24	1/8-27	0.86	0.78	0.50	0.13	0.19
2501-03-02-FG	3/16	3/8-24	1/8-27	0.83	0.72	0.44	0.13	0.19
2501-04-02	1/4	7/16-20	1/8-27	0.89	0.78	0.50	0.17	0.19
2501-04-02-FG	1/4	7/16-20	1/8-27	0.89	0.76	0.44	0.17	0.19
2501-04-04	1/4	7/16-20	1/4-18	0.95	1.09	0.63	0.17	0.28
2501-04-04-FG	1/4	7/16-20	1/4-18	1.05	1.09	0.56	0.17	0.28
2501-04-06	1/4	7/16-20	3/8-18	1.05	1.22	0.81	0.17	0.41
2501-04-06-FG	1/4	7/16-20	3/8-18	1.12	1.22	0.75	0.17	0.41
2501-04-08	1/4	7/16-20	1/2-14	1.11	1.47	0.94	0.17	0.53
2501-04-08-FG	1/4	7/16-20	1/2-14	1.21	1.47	0.88	0.17	0.53
2501-04-12	1/4	7/16-20	3/4-14	1.20	1.59	1.13	0.17	0.72
2501-05-02	5/16	1/2-20	1/8-27	0.95	0.81	0.56	0.23	0.19
2501-05-02-FG	5/16	1/2-20	1/8-27	0.95	0.78	0.56	0.23	0.19
2501-05-04	5/16	1/2-20	1/4-18	0.98	1.09	0.63	0.23	0.28
2501-05-04-FG	5/16	1/2-20	1/4-18	1.05	1.09	0.56	0.23	0.28
2501-05-06	5/16	1/2-20	3/8-18	1.08	1.22	0.81	0.23	0.41
2501-05-08	5/16	1/2-20	1/2-14	1.14	1.47	0.94	0.23	0.53
2501-06-02	3/8	9/16-18	1/8-27	1.06	0.84	0.63	0.30	0.19
2501-06-02-FG	3/8	9/16-18	1/8-27	1.06	0.90	0.56	0.30	0.19
2501-06-04	3/8	9/16-18	1/4-18	1.06	1.09	0.63	0.30	0.28
2501-06-04-FG	3/8	9/16-18	1/4-18	1.06	1.09	0.56	0.30	0.28
2501-06-06	3/8	9/16-18	3/8-18	1.15	1.22	0.81	0.30	0.41
2501-06-06-FG	3/8	9/16-18	3/8-18	1.14	1.22	0.75	0.30	0.41
2501-06-08	3/8	9/16-18	1/2-14	1.22	1.47	0.94	0.30	0.53
2501-06-08-FG	3/8	9/16-18	1/2-14	1.22	1.47	0.88	0.30	0.53
2501-06-12	3/8	9/16-18	3/4-14	1.31	1.59	1.13	0.30	0.72
2501-06-16	3/8	9/16-18	1-11 1/2	1.44	1.97	1.38	0.30	0.94
2501-08-02	1/2	3/4-16	1/8-27	1.25	0.94	0.81	0.39	0.19
2501-08-04	1/2	3/4-16	1/4-18	1.25	1.19	0.81	0.39	0.28
2501-08-04-FG	1/2	3/4-16	1/4-18	1.25	1.22	0.75	0.39	0.28

2501 90 DEGREE MALE ELBOW

(Con't)

SAE J514 070202

MS51504

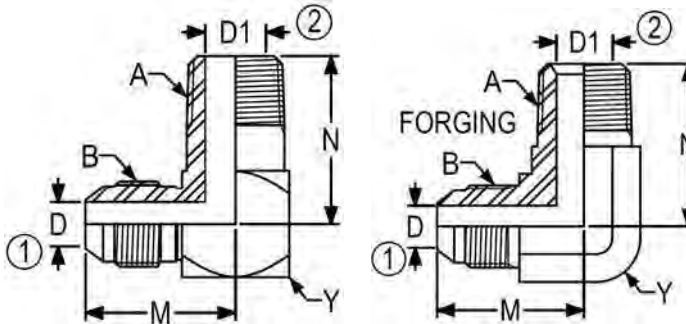

*Non forging parts are brazed construction

PART NO	TUBE OD	B UN/UNF-2A	A NPTF	M	N	Y	D	D1
2501-08-06	1/2	3/4-16	3/8-18	1.25	1.22	0.81	0.39	0.41
2501-08-06-FG	1/2	3/4-16	3/8-18	1.25	1.22	0.75	0.39	0.41
2501-08-08	1/2	3/4-16	1/2-14	1.31	1.47	0.94	0.39	0.53
2501-08-08-FG	1/2	3/4-16	1/2-14	1.33	1.47	0.88	0.39	0.53
2501-08-12	1/2	3/4-16	3/4-14	1.40	1.59	1.13	0.39	0.72
2501-08-12-FG	1/2	3/4-16	3/4-14	1.42	1.59	1.06	0.39	0.72
2501-08-16	1/2	3/4-16	1-11 1/2	1.53	1.97	1.38	0.39	0.94
2501-10-04	5/8	7/8-14	1/4-18	1.45	1.25	0.94	0.48	0.28
2501-10-06	5/8	7/8-14	3/8-18	1.45	1.28	0.94	0.48	0.41
2501-10-06-FG	5/8	7/8-14	3/8-18	1.45	1.28	0.88	0.48	0.41
2501-10-08	5/8	7/8-14	1/2-14	1.45	1.47	0.94	0.48	0.53
2501-10-08-FG	5/8	7/8-14	1/2-14	1.45	1.47	0.88	0.48	0.53
2501-10-12	5/8	7/8-14	3/4-14	1.55	1.59	1.13	0.48	0.72
2501-10-12-FG	5/8	7/8-14	3/4-14	1.54	1.59	1.06	0.48	0.72
2501-10-16	5/8	7/8-14	1-11 1/2	1.67	1.97	1.38	0.48	0.94
2501-10-16-FG	5/8	7/8-14	1-11 1/2	1.64	1.97	1.31	0.48	0.94
2501-12-06	3/4	1 1/16-12	3/8-18	1.66	1.38	1.13	0.61	0.41
2501-12-08	3/4	1 1/16-12	1/2-14	1.66	1.56	1.13	0.61	0.53
2501-12-08-FG	3/4	1 1/16-12	1/2-14	1.66	1.59	1.06	0.61	0.53
2501-12-12	3/4	1 1/16-12	3/4-14	1.66	1.59	1.13	0.61	0.72
2501-12-12-FG	3/4	1 1/16-12	3/4-14	1.66	1.59	1.06	0.61	0.72
2501-12-16	3/4	1 1/16-12	1-11 1/2	1.78	1.97	1.38	0.61	0.94
2501-12-16-FG	3/4	1 1/16-12	1-11 1/2	1.76	1.97	1.31	0.61	0.94
2501-12-20	3/4	1 1/16-12	1 1/4-11 1/2	1.97	2.38	1.75	0.61	1.25
2501-14-12	7/8	1 3/16-12	3/4-14	1.80	1.66	1.25	0.72	0.72
2501-14-16	7/8	1 3/16-12	1-11 1/2	1.86	1.97	1.38	0.72	0.94
2501-16-08	1	1 5/16-12	1/2-14	1.81	1.69	1.38	0.84	0.53
2501-16-12	1	1 5/16-12	3/4-14	1.81	1.72	1.38	0.84	0.72
2501-16-12-FG	1	1 5/16-12	3/4-14	1.81	1.78	1.31	0.84	0.72
2501-16-16	1	1 5/16-12	1-11 1/2	1.81	1.97	1.38	0.84	0.94
2501-16-16-FG	1	1 5/16-12	1-11 1/2	1.81	1.97	1.31	0.84	0.94
2501-16-20	1	1 5/16-12	1 1/4-11 1/2	2.00	2.38	1.75	0.84	1.25
2501-16-20-FG	1	1 5/16-12	1 1/4-11 1/2	2.01	2.38	1.63	0.84	1.25
2501-16-24	1	1 5/16-12	1 1/2-11 1/2	2.13	2.64	2.00	0.84	1.50

2501 90 DEGREE MALE ELBOW

(Con't)

SAE J514 070202

MS51504

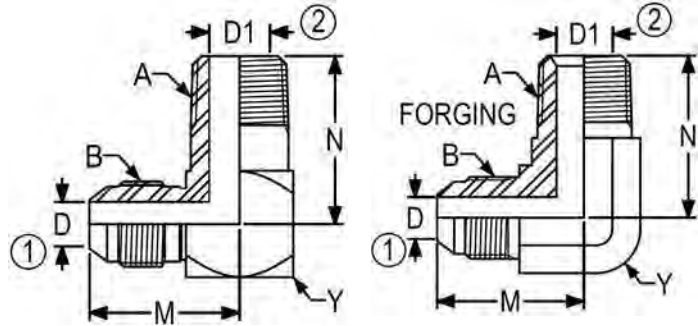

*Non forging parts are brazed construction

PART NO	TUBE OD	B UN/UNF-2A	A NPTF	M	N	Y	D	D1
2501-20-12	1 1/4	1 5/8-12	3/4-14	2.06	1.91	1.75	1.08	0.72
2501-20-16	1 1/4	1 5/8-12	1-11 1/2	2.06	2.16	1.75	1.08	0.94
2501-20-16-FG	1 1/4	1 5/8-12	1-11 1/2	2.06	2.35	1.63	1.08	0.94
2501-20-20	1 1/4	1 5/8-12	1 1/4-11 1/2	2.06	2.38	1.75	1.08	1.25
2501-20-20-FG	1 1/4	1 5/8-12	1 1/4-11 1/2	2.06	2.38	1.63	1.08	1.25
2501-20-24	1 1/4	1 5/8-12	1 1/2-11 1/2	2.19	2.64	2.00	1.08	1.50
2501-20-24-FG	1 1/4	1 5/8-12	1 1/2-11 1/2	2.30	2.64	1.88	1.08	1.50
2501-24-16	1 1/2	1 7/8-12	1-11 1/2	2.33	2.28	2.00	1.31	0.94
2501-24-20	1 1/2	1 7/8-12	1 1/4-11 1/2	2.33	2.50	2.00	1.31	1.25
2501-24-20-FG	1 1/2	1 7/8-12	1 1/4-11 1/2	2.33	2.61	1.88	1.31	1.25
2501-24-24	1 1/2	1 7/8-14	1 1/2-11 1/2	2.33	2.64	2.00	1.31	1.50
2501-24-24-FG	1 1/2	1 7/8-12	1 1/2-11 1/2	2.33	2.64	1.81	1.31	1.50
2501-32-24	2	2 1/2-12	1 1/2-11 1/2	3.06	2.95	2.63	1.78	1.50
2501-32-32	2	2 1/2-12	2-11 1/2	3.06	3.00	2.63	1.78	1.94
2501-32-32-FG	2	2 1/2-12	2-11 1/2	3.06	3.00	2.50	1.78	1.86

2501-L 90 DEGREE MALE LONG ELBOW

SAE J514 071502

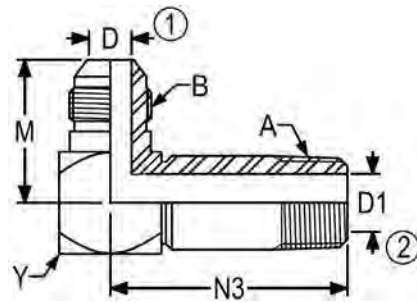

PART NO	TUBE OD	B UN/UNF-2A	A NPTF	M	N3	Y	D	D1
2501-L-04-02	1/4	7/16-20	1/8-27	0.89	1.17	0.50	0.17	0.19
2501-L-04-04	1/4	7/16-20	1/4-18	0.95	1.58	0.63	0.17	0.28
2501-L-05-02	5/16	1/2-20	1/8-27	0.95	1.20	0.56	0.23	0.19
2501-L-05-04	5/16	1/2-20	1/4-18	0.95	1.55	0.56	0.23	0.28
2501-L-06-02	3/8	9/16-18	1/8-27	1.06	1.23	0.63	0.30	0.19
2501-L-06-04	3/8	9/16-18	1/4-18	1.06	1.58	0.63	0.30	0.28
2501-L-06-06	3/8	9/16-18	3/8-18	1.16	1.83	0.81	0.30	0.41
2501-L-06-08	3/8	9/16-18	1/2-14	1.22	2.17	0.94	0.30	0.53
2501-L-08-04	1/2	3/4-16	1/4-18	1.25	1.67	0.81	0.39	0.28
2501-L-08-06	1/2	3/4-16	3/8-18	1.25	1.83	0.81	0.39	0.41
2501-L-08-08	1/2	3/4-16	1/2-14	1.31	2.17	0.94	0.39	0.53
2501-L-08-12	1/2	3/4-16	3/4-14	1.41	2.44	1.13	0.39	0.72
2501-L-10-06	5/8	7/8-14	3/8-18	1.45	1.89	0.94	0.48	0.41
2501-L-10-08	5/8	7/8-14	1/2-14	1.45	2.17	0.94	0.48	0.53
2501-L-10-12	5/8	7/8-14	3/4-14	1.55	2.44	1.13	0.48	0.72
2501-L-12-08	3/4	1 1/16-12	1/2-14	1.66	2.27	1.13	0.61	0.53
2501-L-12-12	3/4	1 1/16-12	3/4-14	1.66	2.44	1.13	0.61	0.72
2501-L-12-16	3/4	1 1/16-12	1-11 1/2	1.78	3.02	1.38	0.61	0.94
2501-L-14-12	7/8	1 3/16-12	3/4-14	1.80	2.50	1.25	0.72	0.72
2501-L-16-12	1	1 5/16-12	3/4-14	1.81	2.56	1.38	0.84	0.72
2501-L-16-16	1	1 5/16-12	1-11 1/2	1.81	3.02	1.38	0.84	0.94
2501-L-20-20	1 1/4	1 5/8-12	1 1/4-11 1/2	2.06	3.69	1.75	1.08	1.25
2501-L-24-24	1 1/2	1 7/8-12	1 1/2-11 1/2	2.33	4.11	2.00	1.31	1.50

2501-LL 90 DEGREE MALE EXTRA LONG

ELBOW

SAE J514 071602

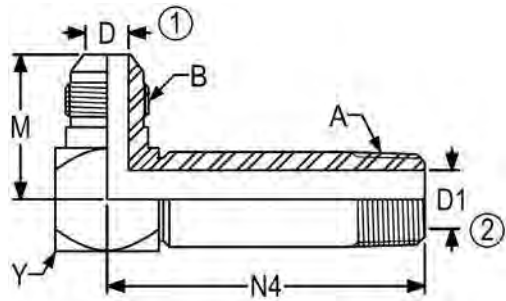

PART NO	TUBE OD	B UN/UNF-2A	A NPTF	M	N4	Y	D	D1
2501-LL-03-02	3/16	3/8-24	1/8-27	0.83	1.56	0.50	0.13	0.19
2501-LL-04-02	1/4	7/16-20	1/8-27	0.89	1.56	0.50	0.17	0.19
2501-LL-04-04	1/4	7/16-20	1/4-18	0.95	2.07	0.63	0.17	0.28
2501-LL-05-02	5/16	1/2-20	1/8-27	0.95	1.59	0.56	0.23	0.19
2501-LL-05-04	5/16	1/2-20	1/4-18	0.95	2.04	0.56	0.23	0.28
2501-LL-06-02	3/8	9/16-18	1/8-27	1.06	1.62	0.63	0.30	0.19
2501-LL-06-04	3/8	9/16-18	1/4-18	1.06	2.07	0.63	0.30	0.28
2501-LL-06-06	3/8	9/16-18	3/8-18	1.16	2.42	0.81	0.30	0.41
2501-LL-06-08	3/8	9/16-18	1/2-14	1.22	2.88	0.94	0.30	0.53
2501-LL-08-04	1/2	3/4-16	1/4-18	1.25	2.16	0.81	0.39	0.28
2501-LL-08-06	1/2	3/4-16	3/8-18	1.25	2.42	0.81	0.39	0.41
2501-LL-08-08	1/2	3/4-16	1/2-14	1.31	2.88	0.94	0.39	0.53
2501-LL-10-08	5/8	7/8-14	1/2-14	1.45	2.87	0.94	0.48	0.53
2501-LL-10-12	5/8	7/8-14	3/4-14	1.55	3.28	1.13	0.48	0.72
2501-LL-12-08	3/4	1 1/16-12	1/2-14	1.66	2.98	1.13	0.61	0.53
2501-LL-12-12	3/4	1 1/16-12	3/4-14	1.66	3.28	1.13	0.61	0.72
2501-LL-14-12	7/8	1 3/16-12	3/4-14	1.80	3.34	1.25	0.72	0.72
2501-LL-16-12	1	1 5/16-12	3/4-14	1.81	3.41	1.38	0.84	0.72
2501-LL-16-16	1	1 5/16-12	1-11 1/2	1.81	4.05	1.38	0.84	0.94
2501-LL-20-20	1 1/4	1 5/8-12	1 1/4-11 1/2	2.06	5.00	1.75	1.08	1.25
2501-LL-24-24	1 1/2	1 7/8-12	1 1/2-11 1/2	2.33	5.55	2.00	1.31	1.50

2501-LLL 90 DEGREE MALE EXTRA EXTRA LONG ELBOW

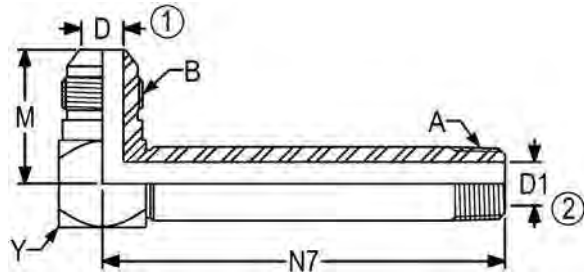

PART NO	TUBE OD	B UN/UNF-2A	A NPTF	M	N7	Y	D	D1
2501-LLL-04-02	1/4	7/16-20	1/8-27	0.89	2.31	0.50	0.17	0.19
2501-LLL-04-04	1/4	7/16-20	1/4-18	0.95	3.06	0.63	0.17	0.28
2501-LLL-05-02	5/16	1/2-20	1/8-27	0.95	2.34	0.56	0.23	0.19
2501-LLL-06-04	3/8	9/16-18	1/4-18	1.06	3.06	0.63	0.30	0.28
2501-LLL-06-06	3/8	9/16-18	3/8-18	1.16	3.75	0.81	0.30	0.41
2501-LLL-08-06	1/2	3/4-16	3/8-18	1.25	3.75	0.81	0.39	0.41
2501-LLL-10-08	5/8	7/8-14	1/2-14	1.45	4.50	0.94	0.48	0.53
2501-LLL-12-12	3/4	1 1/16-12	3/4-14	1.66	5.03	1.13	0.61	0.72
2501-LLL-16-16	1	1 5/16-12	1-11 1/2	1.81	6.34	1.38	0.84	0.94
2501-LLL-20-20	1 1/4	1 5/8-12	1 1/4-11 1/2	2.06	7.34	1.75	1.08	1.25

2502 90 DEGREE FEMALE ELBOW

SAE J514 070203
MS51506

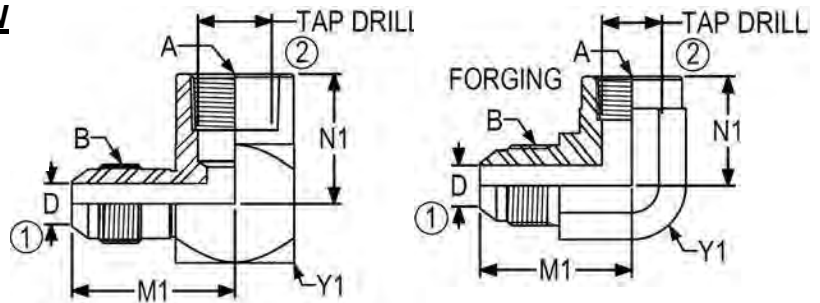

*Non forging parts are brazed construction

PART NO	TUBE OD	B UN/UNF-2A	A NPTF	M1	N1	Y1	D	TAP DRILL
2502-03-02	3/16	3/8-24	1/8-27	1.03	0.66	0.63	0.13	0.33
2502-04-02	1/4	7/16-20	1/8-27	1.08	0.66	0.63	0.17	0.33
2502-04-02-FG	1/4	7/16-20	1/8-27	1.08	0.66	0.56	0.17	0.33
2502-04-04	1/4	7/16-20	1/4-18	1.14	0.88	0.75	0.17	0.43
2502-04-04-FG	1/4	7/16-20	1/4-18	1.22	0.88	0.75	0.17	0.43
2502-04-06	1/4	7/16-20	3/8-18	1.20	1.02	0.88	0.17	0.57
2502-04-08	1/4	7/16-20	1/2-14	1.33	1.23	1.13	0.17	0.70
2502-05-02	5/16	1/2-20	1/8-27	1.08	0.66	0.63	0.23	0.33
2502-05-04	5/16	1/2-20	1/4-18	1.14	0.88	0.75	0.23	0.43
2502-05-06	5/16	1/2-20	3/8-18	1.20	1.02	0.88	0.23	0.57
2502-06-02	3/8	9/16-18	1/8-27	1.06	0.66	0.63	0.30	0.33
2502-06-04	3/8	9/16-18	1/4-18	1.23	0.88	0.75	0.30	0.43
2502-06-04-FG	3/8	9/16-18	1/4-18	1.23	0.88	0.75	0.30	0.43
2502-06-06	3/8	9/16-18	3/8-18	1.30	1.02	0.88	0.30	0.57
2502-06-06-FG	3/8	9/16-18	3/8-18	1.31	1.02	0.88	0.30	0.57
2502-06-08	3/8	9/16-18	1/2-14	1.42	1.23	1.13	0.30	0.70
2502-08-04	1/2	3/4-16	1/4-18	1.25	0.91	0.81	0.39	0.43
2502-08-06	1/2	3/4-16	3/8-18	1.42	1.02	0.88	0.39	0.57
2502-08-06-FG	1/2	3/4-16	3/8-18	1.42	1.02	0.88	0.39	0.57
2502-08-08	1/2	3/4-16	1/2-14	1.55	1.23	1.13	0.39	0.70
2502-08-08-FG	1/2	3/4-16	1/2-14	1.52	1.23	1.06	0.39	0.70
2502-08-12	1/2	3/4-16	3/4-14	1.67	1.36	1.38	0.39	0.91
2502-10-06	5/8	7/8-14	3/8-18	1.45	1.05	0.94	0.48	0.57
2502-10-08	5/8	7/8-14	1/2-14	1.64	1.23	1.13	0.48	0.70
2502-10-08-FG	5/8	7/8-14	1/2-14	1.64	1.23	1.06	0.48	0.70
2502-10-12	5/8	7/8-14	3/4-14	1.77	1.36	1.38	0.48	0.91
2502-12-08	3/4	1 1/16-12	1/2-14	1.76	1.23	1.13	0.61	0.70
2502-12-12	3/4	1 1/16-12	3/4-14	1.89	1.36	1.38	0.61	0.91
2502-12-12-FG	3/4	1 1/16-12	3/4-14	1.89	1.36	1.31	0.61	0.91
2502-12-16	3/4	1 1/16-12	1-11 1/2	2.02	1.62	1.63	0.61	1.14
2502-14-12	7/8	1 3/16-12	3/4-14	1.86	1.42	1.38	0.72	0.91
2502-16-12	1	1 5/16-12	3/4-14	2.05	1.36	1.38	0.84	0.91

2502 90 DEGREE FEMALE ELBOW

(Con.)

SAE J514 070203

MS51506

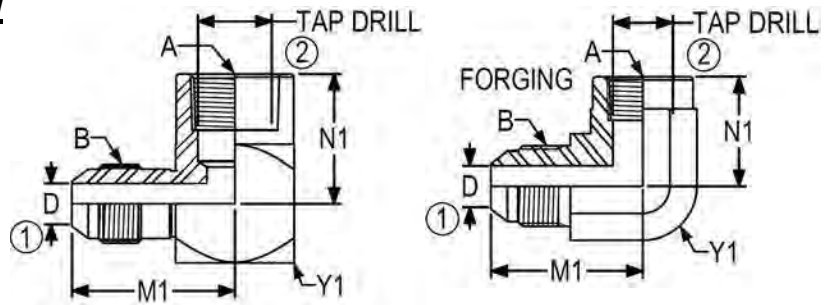

*Non forging parts are brazed construction

PART NO	TUBE OD	B UN/UNF-2A	A NPTF	M1	N1	Y1	D	TAP DRILL
2502-16-16	1	1 5/16-12	1-11 1/2	2.17	1.62	1.63	0.84	1.14
2502-16-16-FG	1	1 5/16-12	1-11 1/2	2.17	1.62	1.63	0.84	1.14
2502-16-20	1	1 5/16-12	1 1/4-11 1/2	2.36	1.70	2.00	0.84	1.48
2502-20-16	1 1/4	1 5/8-12	1-11 1/2	1.62	2.15	1.63	1.08	1.14
2502-20-20	1 1/4	1 5/8-12	1 1/4-11 1/2	2.33	1.70	2.00	1.08	1.48
2502-20-20-FG	1 1/4	1 5/8-12	1 1/4-11 1/2	2.33	1.70	1.88	1.08	1.48
2502-24-24	1 1/2	1 7/8-12	1 1/2-11 1/2	2.89	2.08	2.38	1.31	1.72
2502-32-32	2	2 1/2-12	2-11 1/2	3.30	2.39	2.88	1.78	2.19
2502-32-32-FG	2	2 1/2-12	2-11 1/2	3.30	2.39	2.50	1.78	2.05

Product Data

Tube Fittings

2503 45 DEGREE MALE ELBOW

SAE J514 070302

MS51508

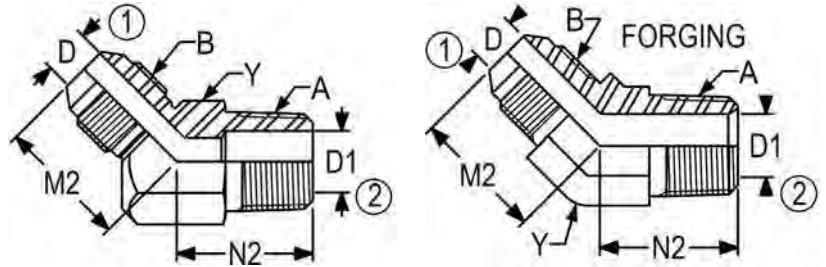

*Non forging parts are brazed construction

PART NO	TUBE OD	B UN/UNF-2A	A NPTF	M2	N2	Y	D	D1
2503-02-02	1/8	5/16-24	1/8-27	0.68	0.64	0.50	0.06	0.19
2503-02-02-FG	1/8	5/16-24	1/8-27	0.69	0.52	0.44	0.06	0.19
2503-03-02	3/16	3/8-24	1/8-27	0.75	0.64	0.50	0.13	0.19
2503-03-02-FG	3/16	3/8-14	1/8-24	0.69	0.52	0.44	0.13	0.19
2503-04-02	1/4	7/16-20	1/8-27	0.72	0.64	0.50	0.17	0.19
2503-04-02-FG	1/4	7/16-20	1/8-27	0.72	0.64	0.44	0.17	0.19
2503-04-04	1/4	7/16-20	1/4-18	0.81	0.84	0.63	0.17	0.28
2503-04-04-FG	1/4	7/16-20	1/4-18	0.82	0.86	0.56	0.17	0.28
2503-04-06	1/4	7/16-20	3/8-18	0.76	0.95	0.81	0.17	0.41
2503-04-08	1/4	7/16-20	1/2-14	0.90	1.17	0.94	0.17	0.53
2503-04-12	1/4	7/16-20	3/4-14	0.87	1.20	1.13	0.17	0.72
2503-05-02	5/16	1/2-20	1/8-27	0.77	0.64	0.56	0.23	0.19
2503-05-02-FG	5/16	1/2-20	1/8-27	0.77	0.64	0.56	0.23	0.19
2503-05-04	5/16	1/2-20	1/4-18	0.82	0.88	0.63	0.23	0.28
2503-05-04-FG	5/16	1/2-20	1/4-18	0.82	0.88	0.56	0.23	0.28
2503-05-06	5/16	1/2-20	3/8-18	0.85	0.95	0.81	0.23	0.41
2503-06-02	3/8	9/16-18	1/8-27	0.83	0.65	0.63	0.30	0.19
2503-06-02-FG	3/8	9/16-18	1/8-27	0.83	0.67	0.56	0.30	0.19
2503-06-04	3/8	9/16-18	1/4-18	0.83	0.86	0.63	0.30	0.30
2503-06-04-FG	3/8	9/16-18	1/4-18	0.83	0.86	0.56	0.30	0.28
2503-06-06	3/8	9/16-18	3/8-18	0.91	0.95	0.81	0.30	0.41
2503-06-06-FG	3/8	9/16-18	3/8-18	0.91	0.95	0.75	0.30	0.41
2503-06-08	3/8	9/16-18	1/2-14	1.03	1.17	0.94	0.30	0.53
2503-06-08-FG	3/8	9/16-18	1/2-14	0.88	1.17	0.88	0.30	0.53
2503-06-12	3/8	9/16-18	3/4-14	0.92	1.20	1.13	0.30	0.72
2503-08-04	1/2	3/4-16	1/4-18	0.98	1.01	0.81	0.39	0.28
2503-08-04-FG	1/2	3/4-16	1/4-18	0.98	0.95	0.75	0.39	0.28
2503-08-06	1/2	3/4-16	3/8-18	0.98	0.95	0.81	0.39	0.41
2503-08-06-FG	1/2	3/4-16	3/8-18	0.98	0.95	0.75	0.39	0.41
2503-08-08	1/2	3/4-16	1/2-14	1.13	1.17	0.94	0.39	0.53
2503-08-08-FG	1/2	3/4-16	1/2-14	1.11	1.17	0.88	0.39	0.53
2503-08-12	1/2	3/4-16	3/4-14	1.19	1.20	1.13	0.39	0.72
2503-08-12-FG	1/2	3/4-16	3/4-14	1.04	1.20	1.06	0.39	0.72

2503 45 DEGREE MALE ELBOW

(Con't)

SAE J514 070302

MS51508

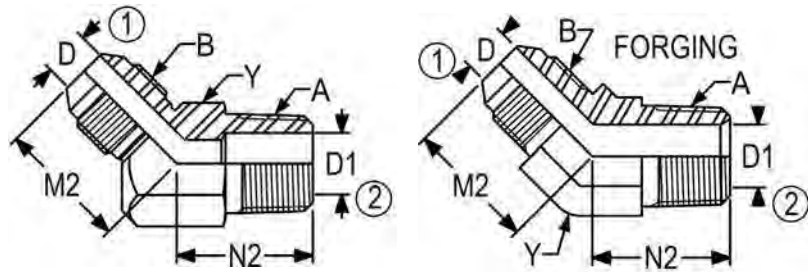

*Non forging parts are brazed construction

PART NO	TUBE OD	B UN/UNF-2A	A NPTF	M2	N2	Y	D	D1
2503-10-04	5/8	1/4-18	7/8-14	1.01	1.11	0.94	0.48	0.28
2503-10-06	5/8	7/8-14	3/8-18	1.11	1.06	0.94	0.48	0.41
2503-10-06-FG	5/8	7/8-14	3/8-18	1.11	0.98	0.88	0.48	0.41
2503-10-08	5/8	7/8-14	1/2-14	1.11	1.17	0.94	0.48	0.53
2503-10-08-FG	5/8	7/8-14	1/2-14	1.11	1.17	0.88	0.48	0.53
2503-10-12	5/8	7/8-14	3/4-14	1.26	1.20	1.13	0.48	0.64
2503-10-12-FG	5/8	7/8-14	3/4-14	1.08	1.20	1.06	0.48	0.72
2503-12-08	3/4	1 1/16-12	1/2-14	1.28	1.19	1.13	0.61	0.53
2503-12-08-FG	3/4	1 1/16-12	1/2-14	1.28	1.20	1.06	0.61	0.53
2503-12-12	3/4	1 1/16-12	3/4-14	1.28	1.20	1.13	0.61	0.72
2503-12-12-FG	3/4	1 1/16-12	3/4-14	1.28	1.20	1.06	0.61	0.72
2503-12-16	3/4	1 1/16-12	1-11 1/2	1.42	1.48	1.38	0.61	0.94
2503-12-16-FG	3/4	1 1/16-12	1-11 1/2	1.42	1.48	1.31	0.61	0.94
2503-14-12	7/8	1 3/16-12	3/4-14	1.39	1.25	1.38	0.72	0.72
2503-14-12-FG	7/8	1 3/16-12	3/4-14	1.45	1.26	1.31	0.72	0.72
2503-16-08	1	1 5/16-12	1/2-14	1.47	1.49	1.38	0.84	0.53
2503-16-12	1	1 5/16-12	3/4-14	1.47	1.28	1.38	0.84	0.72
2503-16-12-FG	1	1 5/16-12	3/4-14	1.47	1.29	1.31	0.84	0.72
2503-16-16	1	1 5/16-12	1-11 1/2	1.47	1.48	1.38	0.84	0.94
2503-16-16-FG	1	1 5/16-12	1-11 1/2	1.47	1.48	1.31	0.84	0.94
2503-16-20	1	1 5/16-12	1 1/4-11 1/2	1.53	1.66	1.75	0.84	1.25
2503-20-16	1 1/4	1 5/8-12	1-11 1/2	1.59	1.63	1.75	1.08	0.94
2503-20-20	1 1/4	1 5/8-12	1 1/4-11 1/2	1.59	1.67	1.75	1.08	1.25
2503-20-20-FG	1 1/4	1 5/8-12	1 1/4-11 1/2	1.59	1.67	1.63	1.08	1.25
2503-20-24	1 1/4	1 5/8-12	1 1/2-11 1/2	1.63	1.75	2.00	1.08	1.50
2503-24-24	1 1/2	1 7/8-12	1 1/2-11 1/2	1.78	1.77	2.00	1.31	1.50
2503-24-24-FG	1 1/2	1 7/8-12	1 1/2-11 1/2	1.78	1.77	1.88	1.31	1.50
2503-32-32	2	2 1/2-12	2-11 1/2	2.22	2.11	2.50	1.78	1.94
2503-32-32-FG	2	2 1/2-12	2-11 1/2	2.22	2.11	2.50	1.78	1.94

2504 45 DEGREE UNION ELBOW

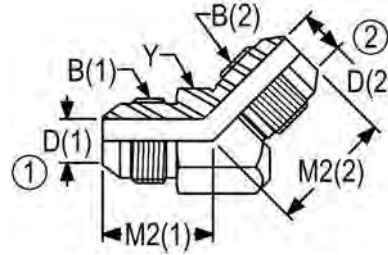

PART NO	TUBE OD	B (1) UN/UNF-2A	B (2) UN/UNF-2A	M2 (1)	M2 (2)	Y	D (1)	D (2)
2504-04-04	1/4-1/4	7/16-20	7/16-20	0.72	0.80	0.50	0.17	0.17
2504-06-06	3/8-3/8	9/16-18	9/16-18	0.83	0.88	0.63	0.30	0.30
2504-08-06	1/2-3/8	3/4-16	9/16-18	0.98	1.07	0.81	0.39	0.30
2504-08-08	1/2-1/2	3/4-16	3/4-16	0.98	1.10	0.81	0.39	0.39
2504-10-10	5/8-5/8	7/8-14	7/8-14	1.11	1.11	0.94	0.48	0.48
2504-12-12	3/4-3/4	1 1/16-12	1 1/16-12	1.28	1.40	1.13	0.61	0.61
2504-16-16	1-1	1 5/16-12	1 5/16-12	1.47	1.54	1.38	0.84	0.84

2505 45 DEGREE FEMALE ELBOW

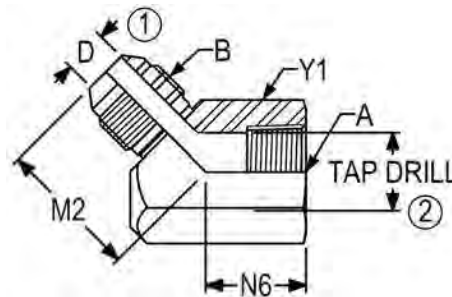

PART NO	TUBE OD	B UN/UNF-2A	A NPTF	M2	N6	Y1	D	TAP DRILL
2505-04-02	1/4	7/16-20	1/8-27	0.86	0.80	0.63	0.17	0.33
2505-04-04	1/4	7/16-20	1/4-18	0.88	0.63	0.75	0.17	0.43
2505-06-04	3/8	9/16-18	1/4-18	1.13	0.63	0.75	0.30	0.43
2505-06-06	3/8	9/16-18	3/8-18	1.06	0.72	0.88	0.30	0.57
2505-08-06	1/2	3/4-16	3/8-18	1.08	0.75	0.88	0.39	0.70
2505-08-08	1/2	3/4-16	1/2-14	1.28	0.91	1.13	0.39	0.70
2505-10-08	5/8	7/8-14	1/2-14	1.31	0.91	1.13	0.48	0.70
2505-12-12	3/4	1 1/16-12	3/4-14	1.54	0.97	1.38	0.61	0.91
2505-16-16	1	1 5/16-12	1-11 1/2	1.69	1.13	1.63	0.84	1.14

2601 MALE BRANCH TEE

SAE J514 070425
MS51512

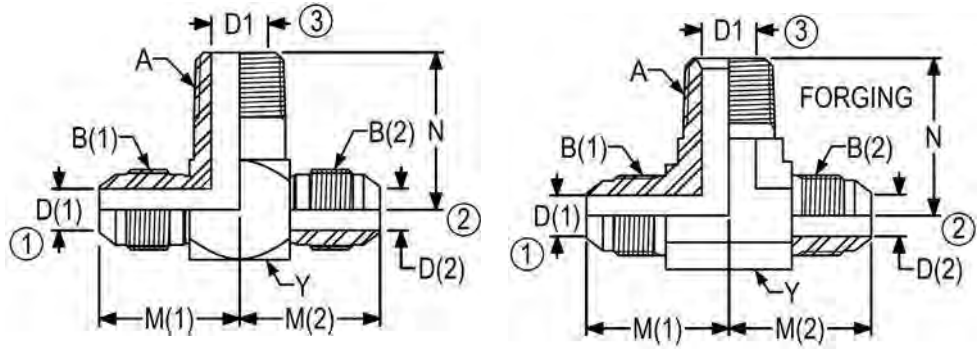

*Non forging parts are brazed construction

PART NO	TUBE OD	B (1) UN/UNF-2A	B (2) UN/UNF-2A	A NPTF	M (1)	M (2)	N	Y	D (1)	D (2)	D1
2601-03-03-02	3/16-3/16	3/8-24	3/8-24	1/8-27	0.83	0.83	0.72	0.44	0.13	0.13	0.19
2601-04-04-02	1/4-1/4	7/16-20	7/16-20	1/8-27	0.89	0.89	0.78	0.50	0.17	0.17	0.19
2601-04-04-02-FG	1/4-1/4	7/16-20	7/16-20	1/8-27	0.89	0.89	0.78	0.44	0.17	0.17	0.19
2601-04-04-04	1/4-1/4	7/16-20	7/16-20	1/4-18	0.95	0.95	1.09	0.63	0.17	0.17	0.28
2601-04-04-04-FG	1/4-1/4	7/16-20	7/16-20	1/4-18	1.05	1.05	1.09	0.56	0.17	0.17	0.28
2601-04-04-06	1/4-1/4	7/16-20	7/16-20	3/8-18	1.05	1.05	1.22	0.81	0.17	0.17	0.41
2601-05-05-02	5/16-5/16	1/2-20	1/2-20	1/8-27	0.95	0.95	0.81	0.56	0.23	0.23	0.19
2601-05-05-04	5/16-5/16	1/2-20	1/2-20	1/4-18	0.98	0.98	1.09	0.63	0.23	0.23	0.28
2601-06-06-02	3/8-3/8	9/16-18	9/16-18	1/8-27	1.06	1.06	0.81	0.63	0.30	0.30	0.19
2601-06-06-04	3/8-3/8	9/16-18	9/16-18	1/4-18	1.06	1.06	1.09	0.63	0.30	0.30	0.28
2601-06-06-04-FG	3/8-3/8	9/16-18	9/16-18	1/4-18	1.06	1.06	1.09	0.56	0.30	0.30	0.28
2601-06-06-06	3/8-3/8	9/16-18	9/16-18	3/8-18	1.16	1.16	1.22	0.81	0.30	0.30	0.41
2601-06-06-06-FG	3/8-3/8	9/16-18	9/16-18	3/8-18	1.14	1.14	1.22	0.75	0.30	0.30	0.41
2601-06-06-08	3/8-3/8	9/16-18	9/16-18	1/2-14	1.22	1.22	1.47	0.94	0.30	0.30	0.53
2601-08-06-08	1/2-3/8	3/4-16	9/16-18	1/2-14	1.31	1.22	1.47	0.94	0.39	0.30	0.53
2601-08-08-04	1/2-1/2	3/4-16	3/4-16	1/4-18	1.25	1.25	1.19	0.81	0.39	0.39	0.28
2601-08-08-06	1/2-1/2	3/4-16	3/4-16	3/8-18	1.25	1.25	1.22	0.81	0.39	0.39	0.41
2601-08-08-06-FG	1/2-1/2	3/4-16	3/4-16	3/8-18	1.25	1.25	1.22	0.75	0.39	0.39	0.41
2601-08-08-08	1/2-1/2	3/4-16	3/4-16	1/2-14	1.31	1.31	1.47	0.94	0.39	0.39	0.53
2601-08-08-08-FG	1/2-1/2	3/4-16	3/4-16	1/2-14	1.33	1.33	1.47	0.88	0.39	0.39	0.53
2601-08-08-12	1/2-1/2	3/4-16	3/4-16	3/4-14	1.41	1.41	1.59	1.13	0.39	0.39	0.72
2601-10-10-06	5/8-5/8	7/8-14	7/8-14	3/8-18	1.45	1.45	1.28	0.94	0.48	0.48	0.41

2601 MALE BRANCH TEE

Con't)

SAE J514 070425

MS51512

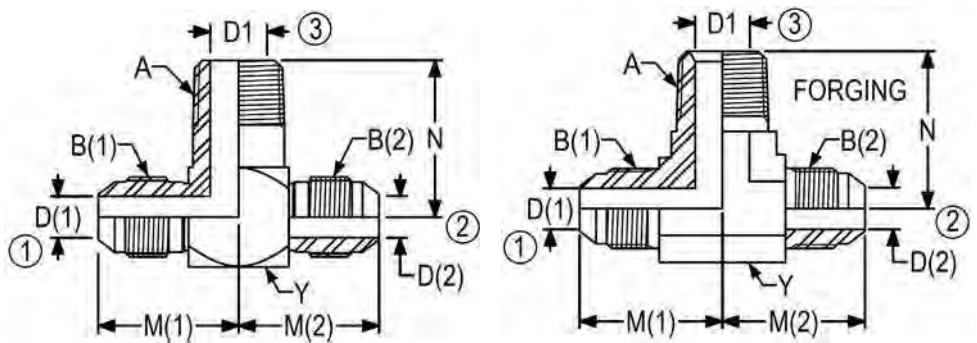

*Non forging parts are brazed construction

PART NO	TUBE OD	B (1) UN/UNF-2A	B (2) UN/UNF-2A	A NPTF	M (1)	M (2)	N	Y	D (1)	D (2)	D1
2601-10-10-08	5/8-5/8	7/8-14	7/8-14	1/2-14	1.45	1.45	1.47	0.94	0.48	0.48	0.53
2601-10-10-08-FG	5/8-5/8	7/8-14	7/8-14	1/2-14	1.45	1.45	1.47	0.88	0.48	0.48	0.53
2601-10-10-12	5/8-5/8	7/8-14	7/8-14	3/4-14	1.55	1.55	1.59	1.13	0.48	0.48	0.72
2601-12-10-12	3/4-5/8	1 1/16-12	7/8-14	3/4-14	1.66	1.55	1.59	1.13	0.61	0.48	0.72
2601-12-12-08	3/4-3/4	1 1/16-12	1 1/16-12	1/2-14	1.66	1.66	1.56	1.13	0.61	0.61	0.53
2601-12-12-12	3/4-3/4	1 1/16-12	1 1/16-12	3/4-14	1.66	1.66	1.59	1.13	0.61	0.61	0.72
2601-12-12-12-FG	3/4-3/4	1 1/16-12	1 1/16-12	3/4-14	1.66	1.66	1.59	1.06	0.61	0.61	0.72
2601-12-12-16	3/4-3/4	1 1/16-12	1 1/16-12	1-11 1/2	1.78	1.78	1.97	1.38	0.61	0.61	0.94
2601-14-14-12	7/8-7/8	1 3/16-12	1 3/16-12	3/4-14	1.80	1.80	1.66	1.25	0.72	0.72	0.72
2601-16-10-12	1-5/8	1 5/16-12	7/8-14	3/4-14	1.81	1.67	1.69	1.38	0.84	0.48	0.72
2601-16-10-12-FG	1-5/8	1 5/16-12	7/8-14	3/4-14	1.81	1.64	1.78	1.31	0.84	0.48	0.72
2601-16-12-16	1-3/4	1 5/16-12	1 1/16-12	1-11 1/2	1.81	1.78	1.97	1.38	0.84	0.61	0.94
2601-16-12-20	1-3/4	1 5/16-12	1 1/16-12	1 1/4-11	2.00	1.97	2.38	1.75	0.84	0.61	1.25
2601-16-16-12	1-1	1 5/16-12	1 5/16-12	3/4-14	1.81	1.81	1.72	1.38	0.84	0.84	0.72
2601-16-16-16	1-1	1 5/16-12	1 5/16-12	1-11 1/2	1.81	1.81	1.97	1.38	0.84	0.84	0.94
2601-16-16-16-FG	1-1	1 5/16-12	1 5/16-12	1-11 1/2	1.81	1.81	1.97	1.31	0.84	0.84	0.94
2601-20-20-20	1 1/4-1 1/4	1 5/8-12	1 5/8-12	1 1/4-11	2.06	2.06	2.38	1.75	1.08	1.08	1.25
2601-24-16-12	1 1/2-1	1 7/8-12	1 5/16-12	3/4-14	2.33	2.13	2.03	2.00	1.31	0.84	0.72
2601-24-24-24	1 1/2-1 1/2	1 7/8-12	1 7/8-12	1 1/2-11	2.33	2.33	2.64	2.00	1.31	1.31	1.50
2601-32-32-32	2-2	2 1/2-12	2 1/2-12	2-11 1/2	3.06	3.06	3.00	2.63	1.78	1.78	1.94
2601-32-32-32-FG	2-2	2 1/2-12	2 1/2-12	2-11 1/2	3.06	3.06	3.00	2.50	1.78	1.78	1.94

2602 FEMALE BRANCH TEE

SAE J514 070427
MS51513

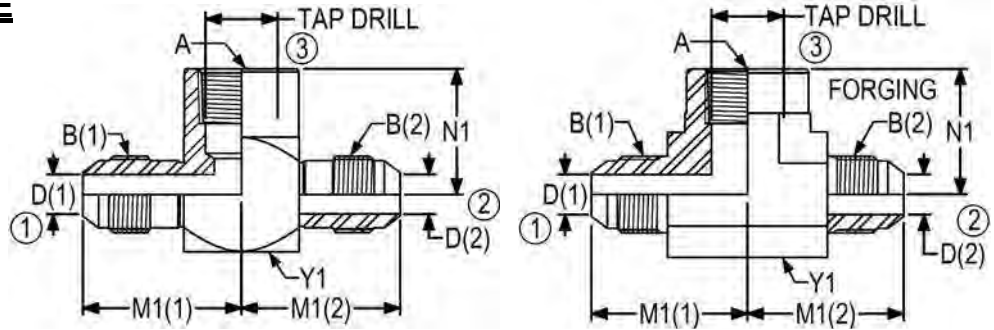

*Non forging parts are brazed construction

PART NO	TUBE OD	B (1) UN/UNF-2A	B (2) UN/UNF-2A	A NPTF	M1 (1)	M1 (2)	N1	Y1	D (1)	D (2)	TAP DRILL
2602-03-03-02	3/16-3/16	3/8-24	3/8-24	1/8-27	1.03	1.03	0.66	0.63	0.13	0.13	0.33
2602-04-04-02	1/4-1/4	7/16-20	7/16-20	1/8-27	1.08	1.08	0.66	0.63	0.17	0.17	0.33
2602-04-04-02-FG	1/4-1/4	7/16-20	7/16-20	1/8-27	1.08	1.08	0.66	0.56	0.17	0.17	0.33
2602-04-04-04	1/4-1/4	7/16-20	7/16-20	1/4-18	1.14	1.14	0.88	0.75	0.17	0.17	0.43
2602-04-04-04-FG	1/4-1/4	7/16-20	7/16-20	1/4-18	1.22	1.22	0.88	0.75	0.17	0.17	0.43
2602-05-05-02	5/16-5/16	1/2-20	1/2-20	1/8-27	1.08	1.08	0.66	0.63	0.23	0.23	0.33
2602-05-05-04	5/16-5/16	1/2-20	1/2-20	1/4-18	1.14	1.14	0.88	0.75	0.23	0.23	0.43
2602-06-06-04	3/8-3/8	9/16-18	9/16-18	1/4-18	1.23	1.23	0.88	0.75	0.30	0.30	0.43
2602-06-06-04-FG	3/8-3/8	9/16-18	9/16-18	1/4-18	1.23	1.23	0.88	0.75	0.30	0.30	0.43
2602-06-06-06	3/8-3/8	9/16-18	9/16-18	3/8-18	1.30	1.30	1.02	0.88	0.30	0.30	0.57
2602-06-06-06-FG	3/8-3/8	9/16-18	9/16-18	3/8-18	1.31	1.31	1.02	0.88	0.30	0.30	0.57
2602-08-08-04	1/2-1/2	3/4-16	3/4-16	1/4-18	1.36	1.36	0.91	0.81	0.39	0.39	0.43
2602-08-08-06	1/2-1/2	3/4-16	3/4-16	3/8-18	1.42	1.42	1.02	0.88	0.39	0.39	0.57
2602-08-08-06-FG	1/2-1/2	3/4-16	3/4-16	3/8-18	1.42	1.42	1.02	0.88	0.39	0.39	0.57
2602-08-08-08	1/2-1/2	3/4-16	3/4-16	1/2-14	1.55	1.55	1.23	1.13	0.39	0.39	0.70
2602-10-10-04	5/8-5/8	7/8-14	7/8-14	1/4-18	1.45	1.45	0.97	0.94	0.48	0.48	0.43
2602-10-10-08	5/8-5/8	7/8-14	7/8-14	1/2-14	1.64	1.64	1.23	1.13	0.48	0.48	0.70
2602-10-10-12	5/8-5/8	7/8-14	7/8-14	3/4-14	1.77	1.77	1.36	1.38	0.48	0.48	0.91
2602-12-12-08	3/4-3/4	1 1/16-12	1 1/16-12	1/2-14	1.76	1.76	1.23	1.13	0.61	0.61	0.70
2602-12-12-12	3/4-3/4	1 1/16-12	1 1/16-12	3/4-14	1.89	1.89	1.36	1.38	0.61	0.61	0.91
2602-12-12-12-FG	3/4-3/4	1 1/16-12	1 1/16-12	3/4-14	1.89	1.89	1.36	1.31	0.61	0.61	0.91
2602-12-12-16	3/4-3/4	1 1/16-12	1 1/16-12	1-11 1/2	2.02	2.02	1.62	1.63	0.61	0.61	1.14
2602-14-14-12	7/8-7/8	1 3/16-12	1 3/16-12	3/4-14	1.86	1.86	1.42	1.38	0.72	0.72	0.91
2602-16-16-12	1-1	1 5/16-12	1 5/16-12	3/4-14	2.05	2.05	1.36	1.38	0.84	0.84	0.91
2602-16-16-16	1-1	1 5/16-12	1 5/16-12	1-11 1/2	2.17	2.17	1.62	1.63	0.84	0.84	1.14
2602-16-16-16-FG	1-1	1 5/16-12	1 5/16-12	1-11 1/2	2.17	2.17	1.62	1.63	0.84	0.84	1.14
2602-20-20-20	1 1/4-1 1/4	1 5/8-12	1 5/8-12	1 1/4-11 1/2	2.33	2.33	1.70	2.00	1.08	1.08	1.48
2602-24-24-24	1 1/2-1 1/2	1 7/8-12	1 7/8-12	1 1/2-11 1/2	2.89	2.89	2.08	2.38	1.31	1.31	1.72
2602-24-24-24-FG	1 1/2-1 1/2	1 7/8-12	1 7/8-12	1 1/2-11 1/2	2.89	2.89	2.08	2.57	1.31	1.31	1.72
2602-32-32-32	2-2	2 1/2-12	2 1/2-12	2-11 1/2	3.30	3.30	2.39	2.88	1.78	1.78	2.19

2603 UNION TEE
 SAE J514 070401
 MS51510

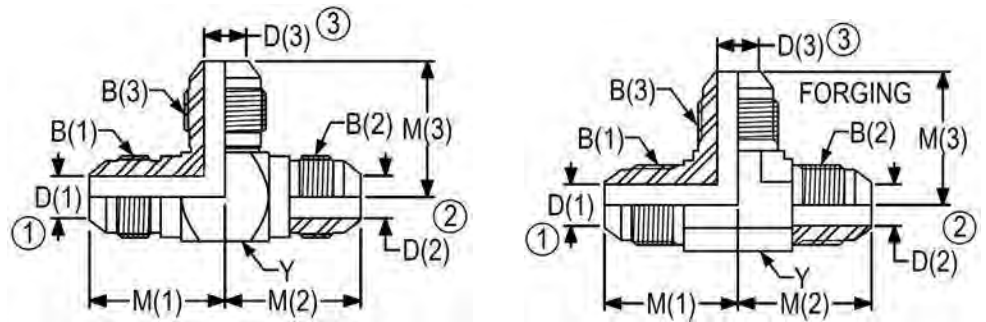

*Non forging parts are brazed construction

PART NO	TUBE OD	B (1) UN/UNF-2A	B (2) UN/UNF-2A	B (3) UN/UNF-2A	M (1)	M (2)	M (3)
2603-04-04-04	1/4-1/4-1/4	7/16-20	7/16-20	7/16-20	0.89	0.89	0.89
2603-04-04-04-FG	1/4-1/4-1/4	7/16-20	7/16-20	7/16-20	7/16-	0.89	0.89
2603-04-04-06	1/4-1/4-3/8	7/16-20	7/16-20	9/16-18	0.95	0.95	1.06
2603-05-05-04	5/16-5/16-1/4	1/2-20	1/2-20	7/16-20	0.95	0.95	0.92
2603-05-05-05	5/16-5/16-5/16	1/2-20	1/2-20	1/2-20	0.95	0.95	0.95
2603-05-05-05-FG	5/16-5/16-5/16	1/2-20	1/2-20	1/2-20	0.95	0.95	0.95
2603-05-05-06	5/16-5/16-3/8	1/2-20	1/2-20	9/16-18	0.98	0.98	1.06
2603-06-06-04	3/8-3/8-1/4	9/16-18	9/16-18	7/16-20	1.06	1.06	0.95
2603-06-06-06	3/8-3/8-3/8	9/16-18	9/16-18	9/16-18	1.06	1.06	1.06
2603-06-06-06-FG	3/8-3/8-3/8	9/16-18	9/16-18	9/16-18	1.06	1.06	1.06
2603-06-06-08	3/8-3/8-1/2	9/16-18	9/16-18	3/4-16	1.16	1.16	1.25
2603-06-06-10	3/8-3/8-5/8	9/16-18	9/16-18	7/8-14	1.22	1.22	1.45
2603-08-06-06	1/2-3/8-3/8	3/4-16	9/16-18	9/16-18	1.25	1.16	1.16
2603-08-08-04	1/2-1/2-1/4	3/4-16	3/4-16	7/16-20	1.25	1.25	1.05
2603-08-08-06	1/2-1/2-3/8	3/4-16	3/4-16	9/16-18	1.25	1.25	1.16
2603-08-08-08	1/2-1/2-1/2	3/4-16	3/4-16	3/4-16	1.25	1.25	1.25
2603-08-08-08-FG	1/2-1/2-1/2	3/4-16	3/4-16	3/4-16	1.25	1.25	1.25

PART NO	Y	D (1)	D (2)	D (3)
2603-04-04-04	0.50	0.17	0.17	0.17
2603-04-04-04-FG	0.44	0.17	0.17	0.17
2603-04-04-06	0.63	0.17	0.17	0.30
2603-05-05-04	0.56	0.23	0.23	0.17
2603-05-05-05	0.56	0.23	0.23	0.23
2603-05-05-05-FG	0.56	0.23	0.23	0.23
2603-05-05-06	0.63	0.23	0.23	0.30
2603-06-06-04	0.63	0.30	0.30	0.17
2603-06-06-06	0.63	0.30	0.30	0.30
2603-06-06-06-FG	0.56	0.30	0.30	0.30
2603-06-06-08	0.81	0.30	0.30	0.39
2603-06-06-10	0.94	0.30	0.30	0.48
2603-08-06-06	0.81	0.39	0.30	0.30
2603-08-08-04	0.81	0.39	0.39	0.17
2603-08-08-06	0.81	0.39	0.39	0.30
2603-08-08-08	0.81	0.39	0.39	0.39
2603-08-08-08-FG	0.75	0.39	0.39	0.39

2603 UNION TEE (Con't)

SAE J514 070401
MS51510

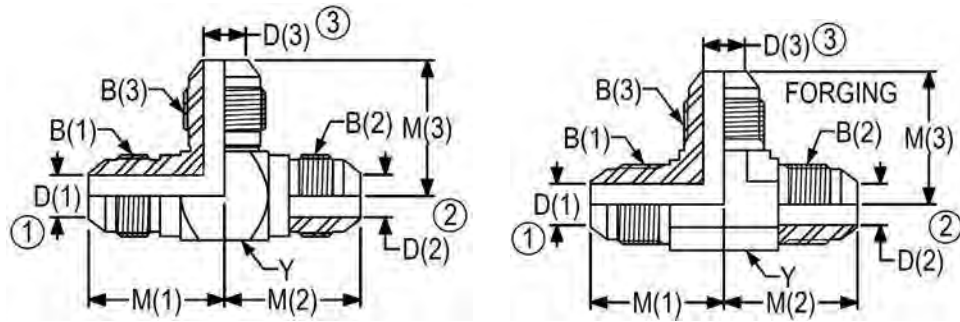

*Non forging parts are brazed

PART NO	TUBE OD	B (1) UN/UNF-2A	B (2) UN/UNF-2A	B (3) UN/UNF-2A	M (1)	M (2)	M (3)
2603-08-08-10	1/2-1/2-5/8	3/4-16	3/4-16	7/8-14	1.31	1.31	1.45
2603-08-08-10-FG	1/2-1/2-5/8	3/4-16	3/4-16	7/8-14	1.33	1.33	1.45
2603-08-08-12	1/2-1/2-3/4	3/4-16	3/4-16	1 1/16-12	1.41	1.41	1.66
2603-10-08-08	5/8-1/2-1/2	7/8-14	3/4-16	3/4-16	1.45	1.31	1.31
2603-10-08-08-FG	5/8-1/2-1/2	7/8-14	3/4-16	3/4-16	1.45	1.33	1.33
2603-10-08-10	5/8-1/2-5/8	7/8-14	3/4-16	7/8-14	1.45	1.31	1.45
2603-10-08-10-FG	5/8-1/2-5/8	7/8-14	3/4-16	7/8-14	1.45	1.33	1.45
2603-10-10-04	5/8-5/8-1/4	7/8-14	7/8-14	7/16-20	1.45	1.45	1.11
2603-10-10-08	5/8-5/8-1/2	7/8-14	7/8-14	3/4-16	1.45	1.45	1.31
2603-10-10-08-FG	5/8-5/8-1/2	7/8-14	7/8-14	3/4-16	1.45	1.45	1.33
2603-10-10-10	5/8-5/8-5/8	7/8-14	7/8-14	7/8-14	1.45	1.45	1.45
2603-10-10-10-FG	5/8-5/8-5/8	7/8-14	7/8-14	7/8-14	1.45	1.45	1.45
2603-10-10-12	5/8-5/8-3/4	7/8-14	7/8-14	1 1/16-12	1.55	1.55	1.66
2603-12-08-10	3/4-1/2-5/8	1 1/16-12	3/4-16	7/8-14	1.66	1.41	1.55
2603-12-08-12	3/4-1/2-3/4	1 1/16-12	3/4-16	1 1/16-12	1.66	1.40	1.66

PART NO	Y	D (1)	D (2)	D (3)
2603-08-08-10	0.94	0.39	0.39	0.48
2603-08-08-10-FG	0.88	0.39	0.39	0.48
2603-08-08-12	1.13	0.39	0.39	0.61
2603-10-08-08	0.94	0.48	0.39	0.39
2603-10-08-08-FG	0.75	0.48	0.39	0.39
2603-10-08-10	0.94	0.48	0.39	0.48
2603-10-08-10-FG	0.88	0.48	0.39	0.48
2603-10-10-04	0.94	0.48	0.48	0.17
2603-10-10-08	0.94	0.48	0.48	0.39
2603-10-10-08-FG	0.88	0.48	0.48	0.39
2603-10-10-10	0.94	0.48	0.48	0.48
2603-10-10-10-FG	0.88	0.48	0.48	0.48
2603-10-10-12	1.13	0.48	0.48	0.61
2603-12-08-10	1.13	0.61	0.39	0.48
2603-12-08-12	1.13	0.61	0.39	0.61

2603 UNION TEE (Con't)

SAE J514 070401
MS51510

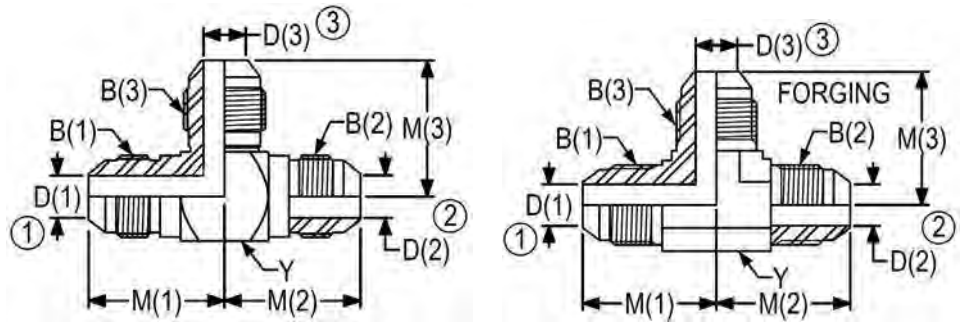

Non forging parts are brazed construction

PART NO	TUBE OD	B (1) UN/UNF-2A	B (2) UN/UNF-2A	B (3) UN/UNF-2A	M (1)	M (2)	M (3)
2603-12-10-10	3/4-5/8-5/8	1 1/16-12	7/8-14	7/8-14	1.66	1.55	1.55
2603-12-10-12	3/4-5/8-3/4	1 1/16-12	7/8-14	1 1/16-12	1.66	1.55	1.66
2603-12-10-12-FG	3/4-5/8-3/4	1 1/16-12	7/8-14	1 1/16-12	1.66	1.54	1.66
2603-12-12-06	3/4-3/4-3/8	1 1/16-12	1 1/16-12	9/16-18	1.66	1.66	1.31
2603-12-12-08	3/4-3/4-1/2	1 1/16-12	1 1/16-12	3/4-16	1.66	1.66	1.41
2603-12-12-08-FG	3/4-3/4-1/2	1 1/16-12	1 1/16-12	3/4-16	1.66	1.66	1.42
2603-12-12-10	3/4-3/4-5/8	1 1/16-12	1 1/16-12	7/8-14	1.66	1.66	1.55
2603-12-12-12	3/4-3/4-3/4	1 1/16-12	1 1/16-12	1 1/16-12	1.66	1.66	1.66
2603-12-12-12-FG	3/4-3/4-3/4	1 1/16-12	1 1/16-12	1 1/16-12	1.66	1.66	1.66
2603-12-12-16	3/4-3/4-1	1 1/16-12	1 1/16-12	1 5/16-12	1.78	1.78	1.81
2603-12-12-20	3/4-3/4-1 1/4	1 1/16-12	1 1/16-12	1 5/8-12	1.97	1.97	2.06
2603-14-14-14	7/8-7/8-7/8	1 3/16-12	1 3/16-12	1 3/16-12	1.80	1.80	1.80
2603-14-14-14-FG	7/8-7/8-7/8	1 3/16-12	1 3/16-12	1 3/16-12	1.80	1.80	1.80
2603-16-12-12	1-3/4-3/4	1 5/16-12	1 1/16-12	1 1/16-12	1.81	1.78	1.78
2603-16-12-16	1-3/4-1	1 5/16-12	1 1/16-12	1 5/16-12	1.81	1.78	1.81
2603-16-16-12	1-1-3/4	1 5/16-12	1 5/16-12	1 1/16-12	1.81	1.81	1.78
2603-16-16-12-FG	1-1-3/4	1 5/16-12	1 5/16-12	1 5/16-12	1.81	1.81	1.76

PART NO	Y	D (1)	D (2)	D (3)
2603-12-10-10	1.13	0.61	0.48	0.48
2603-12-10-12	1.13	0.61	0.48	0.61
2603-12-10-12-FG	1.06	0.61	0.48	0.61
2603-12-12-06	1.13	0.61	0.61	0.30
2603-12-12-08	1.13	0.61	0.61	0.39
2603-12-12-08-FG	1.06	0.61	0.61	0.39
2603-12-12-10	1.13	0.61	0.61	0.48
2603-12-12-12	1.13	0.61	0.61	0.61
2603-12-12-12-FG	1.06	0.61	0.61	0.61
2603-12-12-16	1.38	0.61	0.61	0.84
2603-12-12-20	1.75	0.61	0.61	1.08
2603-14-14-14	1.25	0.72	0.72	0.72
2603-14-14-14-FG	1.31	0.72	0.72	0.72
2603-16-12-12	1.38	0.84	0.61	0.61
2603-16-12-16	1.38	0.84	0.61	0.84
2603-16-16-12	1.38	0.84	0.84	0.61
2603-16-16-12-FG	1.31	0.84	0.84	0.61

2603 UNION TEE (Con't)

SAE J514 070401
MS51510

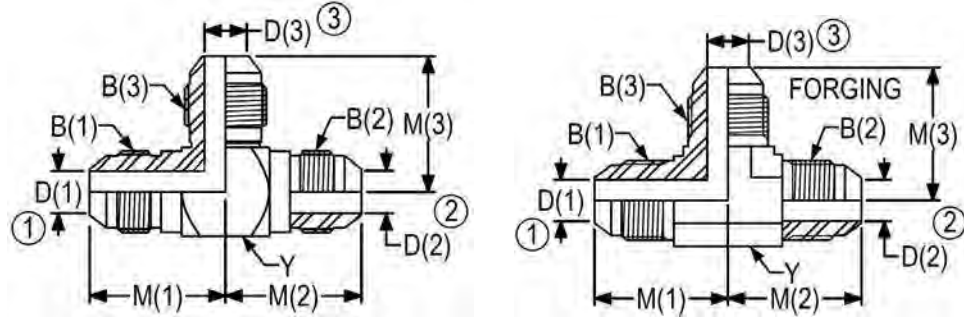

*Non forging parts are brazed construction

PART NO	TUBE OD	B (1) UN/UNF-2A	B (2) UN/UNF-2A	B (3) UN/UNF-2A	M (1)	M (2)	M (3)
2603-16-16-16	1-1-1	1 5/16-12	1 5/16-12	1 5/16-12	1.81	1.81	1.81
2603-16-16-16-FG	1-1-1	1 5/16-12	1 5/16-12	1 5/16-12	1.81	1.81	1.81
2603-16-16-20	1-1-1 1/4	1 5/16-12	1 5/16-12	1 5/8-12	2.00	2.00	2.06
2603-20-12-16	1 1/4-3/4-1	1 5/8-12	1 1/16-12	1 5/16-12	2.06	1.97	2.00
2603-20-16-12	1 1/4-1-3/4	1 5/8-12	1 5/16-12	1 1/16-12	2.06	2.00	1.97
2603-20-16-16	1 1/4-1-1	1 5/8-12	1 5/16-12	1 5/16-12	2.06	2.00	2.00
2603-20-20-08	1 1/4-1 1/4-1/2	1 5/8-12	1 5/8-12	3/4-16	2.06	2.06	1.72
2603-20-20-12	1 1/4-1 1/4-3/4	1 5/8-12	1 5/8-12	1 1/16-12	2.06	2.06	1.97
2603-20-20-20	1 1/4-1 1/4-1 1/4	1 5/8-12	1 5/8-12	1 5/8-12	2.06	2.06	2.06
2603-20-20-20-FG	1 1/4-1 1/4-1 1/4	1 5/8-12	1 5/8-12	1 5/8-12	2.06	2.06	2.06
2603-24-10-16	1 1/2-5/8-1	1 7/8-12	7/8-14	1 5/16-12	2.33	1.98	2.13
2603-24-10-24	1 1/2-5/8-1 1/2	1 7/8-12	7/8-14	1 7/8-12	2.33	1.98	2.33
2603-24-24-24	1 1/2-1 1/2-1 1/2	1 7/8-12	1 7/8-12	1 7/8-12	2.33	2.33	2.33
2603-24-24-24-FG	1 1/2-1 1/2-1 1/2	1 7/8-12	1 7/8-12	1 7/8-12	2.33	2.33	2.33
2603-32-32-32	2-02-2	2 1/2-12	2 1/2-12	2 1/2-12	3.06	3.06	3.06
2603-32-32-32-FG	2-02-2	2 1/2-12	2 1/2-12	2 1/2-12	3.06	3.06	3.06

PART NO	Y	D (1)	D (2)	D (3)
2603-16-16-16	1.38	0.84	0.84	0.84
2603-16-16-16-FG	1.31	0.84	0.84	0.84
2603-16-16-20	1.75	0.84	0.84	1.08
2603-20-12-16	1.75	1.08	0.61	0.84
2603-20-16-12	1.75	1.08	0.84	0.61
2603-20-16-16	1.75	1.08	0.84	0.84
2603-20-20-08	1.75	1.08	1.08	0.39
2603-20-20-12	1.75	1.08	1.08	0.61
2603-20-20-20	1.75	1.08	1.08	1.08
2603-20-20-20-FG	1.63	1.08	1.08	1.08
2603-24-10-16	2.00	1.31	0.48	0.84
2603-24-10-24	2.00	1.31	0.48	1.31
2603-24-24-24	2.00	1.31	1.31	1.31
2603-24-24-24-FG	1.88	1.31	1.31	1.31
2603-32-32-32	2.63	1.78	1.78	1.78
2603-32-32-32-FG	2.50	1.78	1.78	1.78

2605 MALE RUN TEE

SAE J514 070424
MS51511

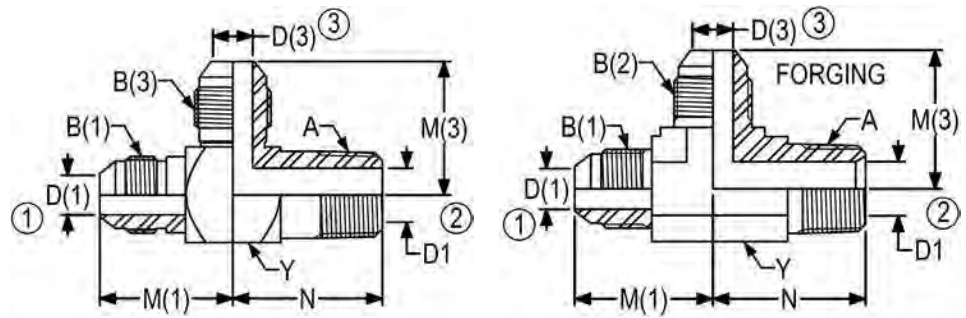

*Non forging parts are brazed construction

PART NO	TUBE OD	B (1) UN/UNF-2A	A NPTF	B (3) UN/UNF-2A	M (1)	N	M (3)
2605-03-02-03	3/16-3/16	3/8-24	1/8-27	3/8-24	0.83	0.75	0.83
2605-04-02-04	1/4-1/4	7/16-20	1/8-27	7/16-20	0.89	0.78	0.89
2605-04-02-04-FG	1/4-1/4	7/16-20	1/8-27	7/16-20	0.89	0.78	0.89
2605-04-04-04	1/4-1/4	7/16-20	1/4-18	7/16-20	0.95	1.09	0.95
2605-04-04-04-FG	1/4-1/4	7/16-20	1/4-18	7/16-20	1.05	1.09	1.05
2605-05-02-05	5/16-5/16	1/2-20	1/8-27	1/2-20	0.95	0.78	0.95
2605-05-04-05	5/16-5/16	1/2-20	1/4-18	1/2-20	0.95	1.06	0.95
2605-06-02-06	3/8-3/8	9/16-18	1/8-27	9/16-18	1.06	0.84	1.06
2605-06-04-06	3/8-3/8	9/16-18	1/4-18	9/16-18	1.06	1.09	1.06
2605-06-04-06-FG	3/8-3/8	9/16-18	1/4-18	9/16-18	1.06	1.09	1.06
2605-06-06-04	3/8-1/4	9/16-18	3/8-18	7/16-20	1.16	1.22	1.05
2605-06-06-06	3/8-3/8	9/16-18	3/8-18	9/16-18	1.16	1.22	1.16
2605-06-06-06-FG	3/8-3/8	9/16-18	3/8-18	9/16-18	1.06	1.22	1.06
2605-06-08-06	3/8-3/8	9/16-18	1/2-14	9/16-18	1.22	1.47	1.22
2605-06-16-16	3/8-1	9/16-18	1-11 1/2	1 5/16-12	1.44	1.97	1.81
2605-06-20-16	3/8-1	9/16-18	1 1/4-11 1/2	1 5/16-12	1.63	2.38	2.00

PART NO	Y	D (1)	D1	D (3)
2605-03-02-03	0.44	0.13	0.19	0.13
2605-04-02-04	0.50	0.17	0.19	0.17
2605-04-02-04-FG	0.44	0.17	0.19	0.17
2605-04-04-04	0.63	0.17	0.28	0.17
2605-04-04-04-FG	0.56	0.17	0.28	0.17
2605-05-02-05	0.56	0.23	0.19	0.23
2605-05-04-05	0.56	0.23	0.28	0.23
2605-06-02-06	0.63	0.30	0.19	0.30
2605-06-04-06	0.63	0.30	0.28	0.30
2605-06-04-06-FG	0.56	0.30	0.28	0.30
2605-06-06-04	0.81	0.30	0.41	0.17
2605-06-06-06	0.81	0.30	0.41	0.30
2605-06-06-06-FG	0.75	0.30	0.41	0.30
2605-06-08-06	0.94	0.30	0.53	0.30
2605-06-16-16	1.38	0.30	0.94	0.84
2605-06-20-16	1.75	0.30	1.25	0.84

2605 MALE RUN TEE

(Con't)

SAE J514 070424

MS51511

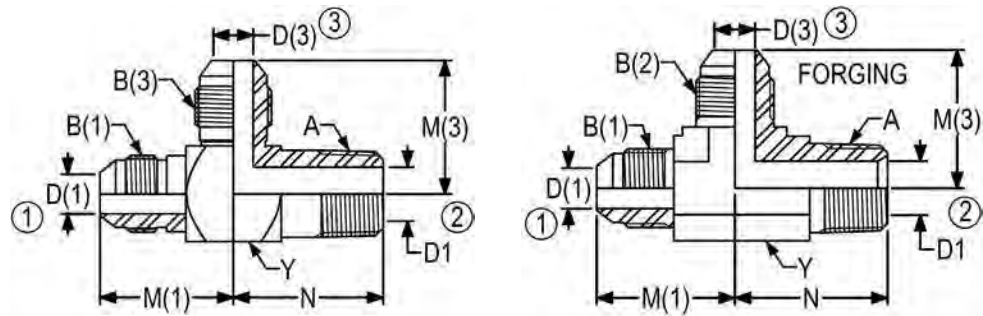

*Non forging parts are brazed construction

PART NO	TUBE OD	B (1) UN/UNF-2A	A NPTF	B (3) UN/UNF-2A	M (1)	N	M (3)
2605-08-04-08	1/2-1/2	3/4-16	1/4-18	3/4-16	1.25	1.19	1.25
2605-08-06-06	1/2-3/8	3/4-16	3/8-18	9/16-18	1.25	1.22	1.16
2605-08-06-08	1/2-1/2	3/4-16	3/8-18	3/4-16	1.25	1.22	1.25
2605-08-06-08-FG	1/2-1/2	3/4-16	3/8-18	3/4-16	1.25	1.22	1.25
2605-08-08-06	1/2-3/8	3/4-16	1/2-14	9/16-18	1.31	1.47	1.22
2605-08-08-08	1/2-1/2	3/4-16	1/2-14	3/4-16	1.31	1.47	1.31
2605-08-08-08-FG	1/2-1/2	3/4-16	1/2-14	3/4-16	1.33	1.47	1.33
2605-08-12-08	1/2-1/2	3/4-16	3/4-14	3/4-16	1.41	1.59	1.41
2605-10-08-10	5/8-5/8	7/8-14	1/2-14	7/8-14	1.45	1.47	1.45
2605-10-12-10	5/8-5/8	7/8-14	3/4-14	7/8-14	1.55	1.59	1.55
2605-12-08-08	3/4-1/2	1 1/16-12	1/2-14	3/4-16	1.66	1.56	1.41
2605-12-08-12	3/4-3/4	1 1/16-12	1/2-14	1 1/16-12	1.66	1.56	1.66
2605-12-12-04	3/4-1/4	1 1/16-12	3/4-14	7/16-20	1.66	1.59	1.20
2605-12-12-12	3/4-3/4	1 1/16-12	3/4-14	1 1/16-12	1.66	1.59	1.66
2605-12-12-12-FG	3/4-3/4	1 1/16-12	3/4-14	1 1/16-12	1.66	1.59	1.66

PART NO	Y	D (1)	D1	D (3)
2605-08-04-08	0.81	0.39	0.28	0.39
2605-08-06-06	0.81	0.39	0.41	0.30
2605-08-06-08	0.81	0.39	0.41	0.39
2605-08-06-08-FG	0.75	0.39	0.41	0.39
2605-08-08-06	0.94	0.39	0.53	0.30
2605-08-08-08	0.94	0.39	0.53	0.39
2605-08-08-08-FG	0.88	0.39	0.53	0.39
2605-08-12-08	1.13	0.39	0.72	0.39
2605-10-08-10	0.94	0.48	0.53	0.48
2605-10-12-10	1.13	0.48	0.72	0.48
2605-12-08-08	1.13	0.61	0.53	0.39
2605-12-08-12	1.13	0.61	0.53	0.61
2605-12-12-04	1.13	0.61	0.72	0.17
2605-12-12-12	1.13	0.61	0.72	0.61
2605-12-12-12-FG	1.06	0.61	0.72	0.61

2605 MALE RUN TEE

(Con't)

SAE J514 070424

MS51511

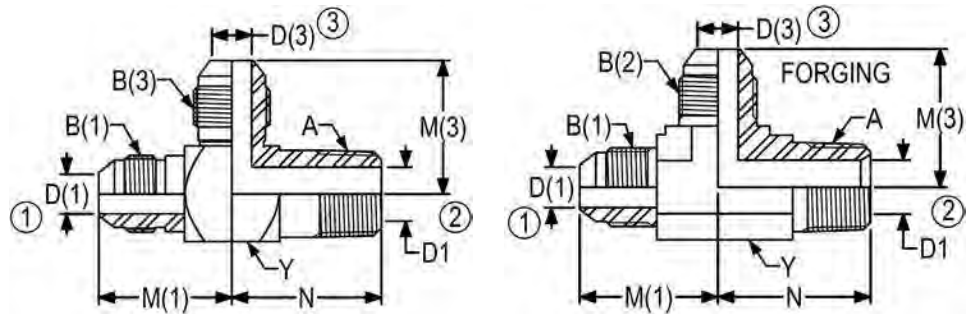

*Non forging parts are brazed construction

PART NO	TUBE OD	B (1) UN/UNF-2A	A NPTF	B (3) UN/UNF-2A	M (1)	N	M (3)
2605-12-16-12	3/4-3/4	1 1/16-12	1-11 1/2	1 1/16-12	1.78	1.97	1.78
2605-12-20-12	3/4-3/4	1 1/16-12	1 1/4-11 1/2	1 1/16-12	1.97	2.38	1.97
2605-14-12-14	7/8-7/8	1 3/16-12	3/4-14	1 3/16-12	1.80	1.66	1.80
2605-16-12-16	1-1	1 5/16-12	3/4-14	1 5/16-12	1.81	1.72	1.81
2605-16-16-10	1-5/8	1 5/16-12	1-11 1/2	7/8-14	1.81	1.97	1.67
2605-16-16-16	1-1	1 5/16-12	1-11 1/2	1 5/16-12	1.81	1.97	1.81
2605-16-16-16-FG	1-1	1 5/16-12	1-11 1/2	1 5/16-12	1.81	1.97	1.81
2605-16-20-10	1-5/8	1 5/16-12	1 1/4-11 1/2	7/8-14	2.00	2.38	1.86
2605-20-20-20	1 1/4-1 1/4	1 5/8-12	1 1/4-11 1/2	1 5/8-12	2.06	2.38	2.06
2605-20-20-20-FG	1 1/4-1 1/4	1 5/8-12	1 1/4-11 1/2	1 5/8-12	2.06	2.38	2.06
2605-24-24-24	1 1/2-1 1/2	1 7/8-12	1 1/2-11 1/2	1 7/8-12	2.33	2.64	2.33
2605-24-24-24-FG	1 1/2-1 1/2	1 7/8-12	1 1/2-11 1/2	1 7/8-12	2.33	2.64	2.33
2605-32-32-32	2-2	2 1/2-12	2-11 1/2	2 1/2-12	3.06	3.00	3.06
2605-32-32-32-FG	2-2	2 1/2-12	2-11 1/2	2 1/2-12	3.06	3.00	3.06

PART NO	Y	D (1)	D1	D (3)
2605-12-16-12	1.38	0.61	0.94	0.61
2605-12-20-12	1.75	0.61	1.25	0.61
2605-14-12-14	1.25	0.72	0.72	0.72
2605-16-12-16	1.38	0.84	0.72	0.84
2605-16-16-10	1.38	0.84	0.94	0.48
2605-16-16-16	1.38	0.84	0.94	0.84
2605-16-16-16-FG	1.31	0.84	0.94	0.84
2605-16-20-10	1.75	0.84	1.25	0.48
2605-20-20-20	1.75	1.08	1.25	1.08
2605-20-20-20-FG	1.63	1.08	1.25	1.08
2605-24-24-24	2.00	1.31	1.50	1.31
2605-24-24-24-FG	1.88	1.31	1.50	1.31
2605-32-32-32	2.63	1.78	1.94	1.78
2605-32-32-32-FG	2.50	1.78	1.94	1.78

2606 FEMALE RUN TEE

SAE J514 070426
MS51514

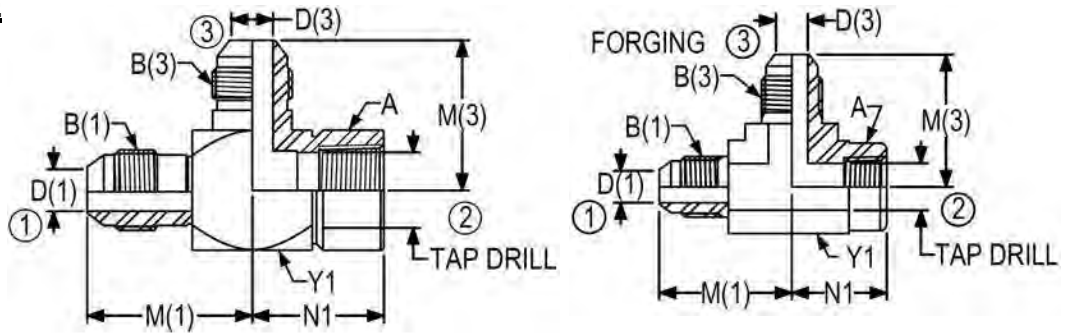

PART NO	TUBE OD	B (1) UN/UNF-2A	A NPTF	B (3) UN/UNF-2A	M1 (1)	N1	M1 (3)	Y1	D (1)	TAP DRILL	D (3)
2606-04-02-04	1/4-1/4	7/16-20	1/8-27	7/16-20	1.08	0.66	1.08	0.63	0.17	0.33	0.17
2606-04-04-04	1/4-1/4	7/16-20	1/4-18	7/16-20	1.02	0.88	1.02	0.75	0.17	0.43	0.17
2606-05-02-05	5/16-5/16	1/2-20	1/8-27	1/2-20	1.08	0.66	1.08	0.63	0.23	0.33	0.23
2606-06-04-06	3/8-3/8	9/16-18	1/4-18	9/16-18	1.23	0.88	1.23	0.75	0.30	0.43	0.30
2606-06-04-06-FG	3/8-3/8	9/16-18	14-18	9/16-18	1.23	0.88	1.23	0.75	0.30	0.43	0.30
2606-06-06-06	3/8-3/8	9/16-18	3/8-18	9/16-18	1.30	1.02	1.30	0.88	0.30	0.57	0.30
2606-08-06-08	1/2-1/2	3/4-16	3/8-18	3/4-16	1.42	1.02	1.42	0.88	0.39	0.57	0.39
2606-08-08-08	1/2-1/2	3/4-16	1/2-14	3/4-16	1.55	1.23	1.55	1.13	0.39	0.70	0.39
2606-10-08-10	5/8-5/8	7/8-14	1/2-14	7/8-14	1.64	1.23	1.64	1.13	0.48	0.70	0.48
2606-12-12-12	3/4-3/4	1 1/16-12	3/4-14	1 1/16-12	1.89	1.36	1.89	1.38	0.61	0.91	0.61
2606-14-12-14	7/8-7/8	1 3/16-12	3/4-14	1 3/16-12	1.86	1.42	1.86	1.38	0.72	0.91	0.72
2606-16-16-16	1-1	1 5/16-12	1-11 1/2	1 5/16-12	2.17	1.62	2.17	1.63	0.84	1.14	0.84
2606-20-20-20	1 1/4-1 1/4	1 5/8-12	1 1/4-11 1/2	1 5/8-12	2.33	1.70	2.33	2.00	1.08	1.48	1.08

2607 MALE RUN/BRANCH TEE

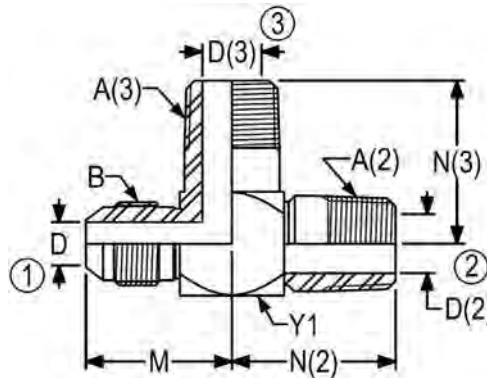

PART NO	TUBE OD	B UN/UNF-2A	A (2) NPTF	A (3) NPTF	M	N (2)	N (3)	Y	D	D1 (2)	D1 (3)
2607-04-02-02	1/4	7/16-20	1/8-27	1/8-27	0.89	0.78	0.78	0.50	0.17	0.19	0.19
2607-06-04-04	3/8	9/16-18	1/4-18	1/4-18	1.06	1.09	1.09	0.63	0.30	0.28	0.28
2607-06-06-06	3/8	9/16-18	3/8-18	3/8-18	1.16	1.22	1.22	0.81	0.30	0.41	0.41
2607-08-08-08	1/2	3/4-16	1/2-14	1/2-14	1.31	1.47	1.47	0.94	0.39	0.53	0.53
2607-10-08-08	5/8	7/8-14	1/2-14	1/2-14	1.45	1.47	1.47	0.94	0.48	0.53	0.53
2607-12-12-08	3/4	1-1/16-12	3/4-14	1/2-14	1.10	1.03	1.56	1.13	0.61	0.72	0.53
2607-12-12-12	3/4	1 1/16-12	3/4-14	3/4-14	1.66	1.59	1.59	1.13	0.61	0.72	0.72
2607-16-16-16	1	1 5/16-12	1-11 1/2	1-11 1/2	1.81	1.97	1.97	1.38	0.84	0.94	0.94

2608 FEMALE RUN/MALE BRANCH TEE

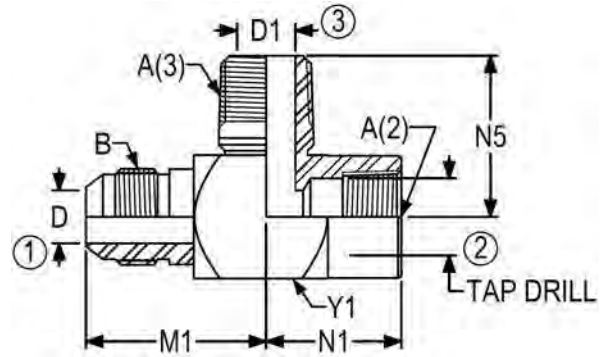

PART NO	TUBE OD	B UN/UNF-2A	A (2) NPTF	A (3) NPTF	M1	N1	N5	Y1	D	TAP DRILL	D1
2608-04-02-02	1/4	7/16-20	1/8-27	1/8-27	1.08	0.66	0.84	0.63	0.17	0.33	0.19
2608-04-04-06	1/4	7/16-20	1/4-18	3/8-18	1.05	0.91	1.22	0.81	0.17	0.43	0.41
2608-06-04-04	3/8	9/16-18	1/4-18	1/4-18	1.23	0.88	1.16	0.75	0.30	0.43	0.28
2608-06-06-06	3/8	9/16-18	3/8-18	3/8-18	1.30	1.02	1.25	0.88	0.30	0.57	0.41
2608-08-06-06	1/2	3/4-16	3/8-18	3/8-18	1.42	1.02	1.25	0.88	0.39	0.57	0.41
2608-10-08-08	5/8	7/8-14	1/2-14	1/2-14	1.64	1.23	1.47	1.13	0.48	0.70	0.53
2608-12-12-12	3/4	1 1/16-12	3/4-14	3/4-14	1.89	1.36	1.72	1.38	0.61	0.91	0.72
2608-16-16-16	1	1 5/16-12	1-11 1/2	1-11 1/2	2.17	1.62	2.09	1.63	0.84	1.14	0.94

2609 FEMALE RUN/BRANCH TEE

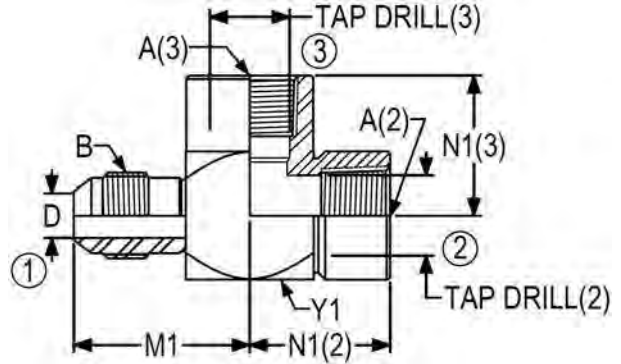

PART NO	TUBE OD	B UN/UNF-2A	A (2) NPTF	A (3) NPTF	M1	N1 (2)	N1 (3)	Y1	D	TAP DRILL (2)	TAP DRILL (3)
2609-04-02-02	1/4	7/16-20	1/8-27	1/8-27	1.08	0.66	0.66	0.63	0.17	0.33	0.33
2609-04-04-04	1/4	7/16-20	1/4-18	1/4-18	1.14	0.88	0.88	0.75	0.17	0.43	0.43
2609-05-04-04	5/16	1/2-20	1/4-18	1/4-18	1.14	0.88	0.88	0.75	0.23	0.43	0.43
2609-06-04-04	3/8	9/16-18	1/4-18	1/4-18	1.23	0.88	0.88	0.75	0.30	0.43	0.43
2609-08-06-06	1/2	3/4-16	3/8-18	3/8-18	1.42	1.02	1.02	0.88	0.39	0.57	0.57
2609-10-08-08	5/8	7/8-14	1/2-14	1/2-14	1.64	1.23	1.23	1.13	0.48	0.70	0.70
2609-12-12-12	3/4	1 1/16-12	3/4-14	3/4-14	1.89	1.36	1.36	1.38	0.61	0.91	0.91
2609-16-12-08	1	1 5/16-12	3/4-14	1/2-14	2.05	1.36	1.36	1.38	0.84	0.91	0.70
2609-16-16-16	1	1 5/16-12	1-11 1/2	1-11 1/2	2.17	1.62	1.63	1.63	0.84	1.14	1.14
2609-20-20-20	1 1/4	1 5/8-12	1 1/4-11 1/2	1 1/4-11 1/2	2.32	1.70	1.70	2.00	1.08	1.48	1.48

2610 MALE RUN/RUN TEE

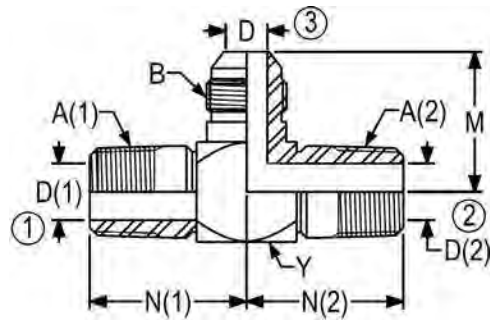

PART NO	TUBE OD	A (1) NPTF	A (2) NPTF	B UN/UNF-2A	N (1)	N (2)	M	Y	D1 (1)	D1 (2)	D
2610-04-04-04	1/4	1/4-18	1/4-18	7/16-20	1.09	1.09	0.95	0.63	0.28	0.28	0.17
2610-04-04-06	3/8	1/4-18	1/4-18	9/16-18	1.09	1.09	1.06	0.63	0.28	0.28	0.30
2610-06-06-06	3/8	3/8-18	3/8-18	9/16-18	1.22	1.22	1.16	0.81	0.41	0.41	0.30
2610-06-06-08	1/2	3/8-18	3/8-18	3/4-16	1.22	1.22	1.25	0.81	0.41	0.41	0.39
2610-08-08-08	1/2	1/2-14	1/2-14	3/4-16	1.47	1.47	1.31	0.94	0.53	0.53	0.39
2610-08-08-10	5/8	1/2-14	1/2-14	7/8-14	1.47	1.47	1.45	0.94	0.53	0.53	0.48
2610-12-12-12	3/4	3/4-14	3/4-14	1 1/16-12	1.59	1.59	1.66	1.13	0.72	0.72	0.61
2610-12-12-16	1	3/4-14	3/4-14	1 5/16-12	1.72	1.72	1.81	1.38	0.72	0.72	0.84
2610-16-16-16	1	1-11 1/2	1 11 1/2	1 5/16-12	1.97	1.97	1.81	1.38	0.94	0.94	0.84
2610-20-20-16	1	1 1/4-11 1/2	1 1/4-11 1/2	1 5/16-12	2.38	2.38	2.00	1.75	1.25	1.25	0.84
2610-20-20-20	1 1/4	1 1/4-11 1/2	1 1/4-11 1/2	1 5/8-12	2.38	2.38	2.00	1.75	1.25	1.25	1.08

2611 MALE RUN/FEMALE BRANCH TEE

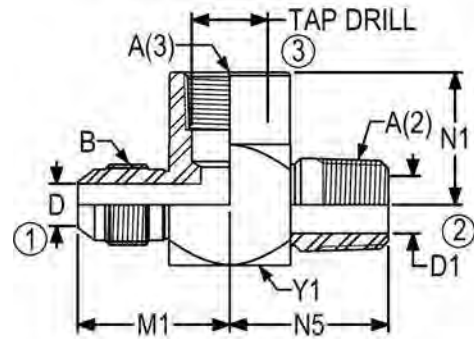

PART NO	TUBE OD	B UN/UNF-2A	A (2) NPTF	A (3) NPTF	M1	N5	N1	Y1	D	D1	TAP DRILL
2611-04-02-02	1/4	7/16-20	1/8-27	1/8-27	0.95	0.84	0.66	0.63	0.17	0.19	0.33
2611-04-04-02	1/4	7/16-20	1/4-18	1/8-27	0.95	1.03	0.66	0.63	0.17	0.28	0.33
2611-04-04-04	1/4	7/16-20	1/4-18	1/4-18	1.01	1.09	0.88	0.75	0.17	0.28	0.43
2611-05-04-02	5/16	1/2-20	1/4-18	1/8-27	1.08	1.03	0.66	0.63	0.23	0.28	0.33
2611-05-04-06	5/16	1/2-20	1/4-18	3/8-18	1.11	1.22	1.02	0.88	0.23	0.28	0.57
2611-06-04-04	3/8	9/16-18	1/4-18	1/4-18	1.13	1.16	0.88	0.75	0.30	0.28	0.43
2611-06-06-06	3/8	9/16-18	3/8-18	3/8-18	1.19	1.25	1.02	0.88	0.30	0.41	0.57
2611-08-06-06	1/2	3/4-16	3/8-18	3/8-18	1.28	1.25	1.02	0.88	0.39	0.41	0.57
2611-08-08-08	1/2	3/4-16	1/2-14	1/2-14	1.41	1.47	1.23	1.13	0.39	0.53	0.70
2611-08-12-12	1/2	3/4-16	3/4-14	3/4-14	1.53	1.72	1.36	1.38	0.39	0.72	0.91
2611-10-08-08	5/8	7/8-14	1/2-14	1/2-14	1.55	1.56	1.23	1.13	0.48	0.53	0.70
2611-12-12-12	3/4	1 1/16-12	3/4-14	3/4-14	1.89	1.59	1.36	1.38	0.61	0.72	0.91
2611-16-16-16	1	1 5/16-12	1-11 1/2	1-11 1/2	1.94	1.97	1.62	1.63	0.84	0.94	1.14

2612 FEMALE RUN/RUN TEE

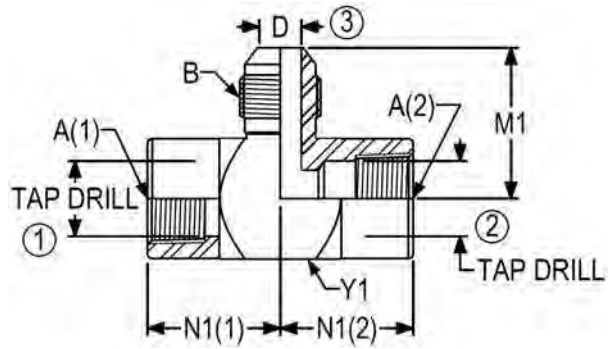

PART NO	TUBE OD	A (1) NPTF	A (2) NPTF	B UN/UNF-2A	N1 (1)	N1 (2)	M1	Y1	TAP DRILL (1)	TAP DRILL (2)	D
2612-02-02-04	1/4	1/8-27	1/8-27	7/16-20	0.66	0.66	1.08	0.63	0.33	0.33	0.17
2612-02-02-05	5/16	1/8-27	1/8-27	1/2-20	0.66	0.66	1.08	0.63	0.33	0.33	0.23
2612-04-04-06	3/8	1/4-18	1/4-18	9/16-18	0.88	0.88	1.23	0.75	0.43	0.43	0.30
2612-06-06-08	1/2	3/8-18	3/8-18	3/4-16	1.02	1.02	1.42	0.88	0.57	0.57	0.39
2612-08-08-08	1/2	1/2-14	1/2-14	3/4-16	1.23	1.23	1.41	1.13	0.70	0.70	0.39
2612-08-08-10	5/8	1/2-14	1/2-14	7/8-14	1.23	1.23	1.64	1.13	0.70	0.70	0.48
2612-12-12-12	3/4	3/4-14	3/4-14	1 1/16-12	1.36	1.36	1.89	1.38	0.91	0.91	0.61
2612-16-16-16	1	1-11 1/2	1-11 1/2	1 5/16-12	1.62	1.62	2.17	1.63	1.14	1.14	0.84

2613 MALE RUN/FEMALE RUN TEE

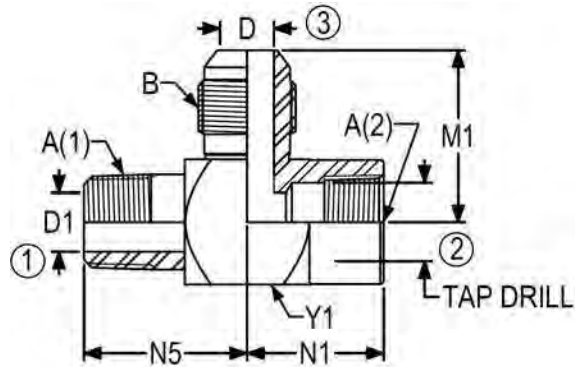

PART NO	TUBE OD	A (1) NPTF	A (2) NPTF	B UN/UNF-2A	N5	N1	M1	Y1	D1	TAP DRILL	D
2613-02-02-04	1/4	1/8-27	1/8-27	7/16-20	0.78	0.66	0.95	0.63	0.19	0.33	0.17
2613-02-02-05	5/16	1/8-27	1/8-27	1/2-20	0.78	0.66	0.98	0.63	0.19	0.33	0.23
2613-04-04-04	1/4	1/4-18	1/4-18	7/16-20	1.09	0.88	1.01	0.75	0.28	0.43	0.17
2613-04-04-06	3/8	1/4-18	1/4-18	9/16-18	1.09	0.88	1.13	0.75	0.28	0.43	0.30
2613-06-04-06	3/8	3/8-18	1/4-18	9/16-18	1.22	0.90	1.16	0.81	0.41	0.43	0.30
2613-06-06-06	3/8	3/8-18	3/8-18	9/16-18	1.22	1.02	1.19	0.88	0.41	0.57	0.30
2613-06-06-08	1/2	3/8-18	3/8-18	3/4-16	1.22	1.02	1.28	0.88	0.41	0.57	0.39
2613-08-08-10	5/8	1/2-14	1/2-14	7/8-14	1.47	1.23	1.55	1.13	0.53	0.70	0.48
2613-12-04-08	1/2	3/4-14	1/4-18	3/4-16	1.59	1.06	1.40	1.13	0.72	0.43	0.39
2613-12-12-12	3/4	3/4-14	3/4-14	1 1/16-12	1.59	1.36	1.89	1.38	0.72	0.91	0.61
2613-16-16-16	1	1-11 1/2	1-11 1/2	1 5/16-12	1.97	1.62	2.17	1.63	0.94	1.14	0.84
2613-20-20-20	1 1/4	1 1/4-11 1/2	1 1/4-11 1/2	1 5/8-12	2.38	1.70	2.33	2.00	1.25	1.48	1.08

2650 UNION CROSS

SAE J514 070501
MS51517

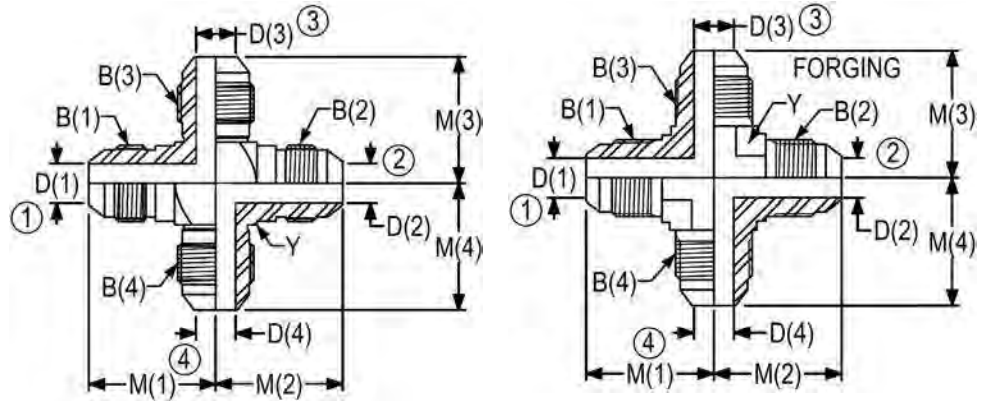

*Non forging parts are brazed construction

PART NO	TUBE OD	B (1) UN/UNF-2A	B (2) UN/UNF-2A	B (3) UN/UNF-2A	B (4) UN/UNF-2A	M (1)	M (2)
2650-04-04-04-04	1/4-1/4-1/4-1/4	7/16-20	7/16-20	7/16-20	7/16-20	0.89	0.89
2650-04-04-04-04-FG	1/4-1/4-1/4-1/4	7/16-20	7/16-20	7/16-20	7/16-20	0.89	0.89
2650-05-05-05-05	5/16-5/16-5/16-5/16	1/2-20	1/2-20	1/2-20	1/2-20	0.95	0.95
2650-06-06-06-06	3/8-3/8-3/8-3/8	9/16-18	9/16-18	9/16-18	9/16-18	1.06	1.06
2650-06-06-06-06-FG	3/8-3/8-3/8-3/8	9/16-18	9/16-18	9/16-18	9/16-18	1.06	1.06
2650-08-08-06-06	1/2-1/2-3/8-3/8	3/4-16	3/4-16	9/16-18	9/16-18	1.25	1.25
2650-08-08-08-08	1/2-1/2-1/2-1/2	3/4-16	3/4-16	3/4-16	3/4-16	1.25	1.25
2650-08-08-08-08-FG	1/2-1/2-1/2-1/2	3/4-16	3/4-16	3/4-16	3/4-16	1.25	1.25
2650-10-10-06-06	5/8-5/8-3/8-3/8	7/8-14	7/8-14	9/16-18	9/16-18	1.45	1.45
2650-10-10-08-08	5/8-5/8-1/2-1/2	7/8-14	7/8-14	3/4-16	3/4-16	1.45	1.45
2650-10-10-10-08	5/8-5/8-5/8-1/2	7/8-14	7/8-14	7/8-14	3/4-16	1.45	1.45
2650-10-10-10-10	5/8-5/8-5/8-5/8	7/8-14	7/8-14	7/8-14	7/8-14	1.45	1.45
2650-10-10-10-10-FG	5/8-5/8-5/8-5/8	7/8-14	7/8-14	7/8-14	7/8-14	1.45	1.45

PART NO	M (3)	M (4)	Y	D (1)	D (2)	D (3)	D (4)
2650-04-04-04-04	0.89	0.89	0.50	0.17	0.17	0.17	0.17
2650-04-04-04-04-FG	0.89	0.89	0.44	0.17	0.17	0.17	0.17
2650-05-05-05-05	0.95	0.95	0.56	0.23	0.23	0.23	0.23
2650-06-06-06-06	1.06	1.06	0.63	0.30	0.30	0.30	0.30
2650-06-06-06-06-FG	1.06	1.06	0.56	0.30	0.30	0.30	0.30
2650-08-08-06-06	1.15	1.15	0.81	0.39	0.39	0.30	0.30
2650-08-08-08-08	1.25	1.25	0.81	0.39	0.39	0.39	0.39
2650-08-08-08-08-FG	1.25	1.25	0.75	0.39	0.39	0.39	0.39
2650-10-10-06-06	1.22	1.22	0.94	0.48	0.48	0.30	0.30
2650-10-10-08-08	1.31	1.31	0.94	0.48	0.48	0.39	0.39
2650-10-10-10-08	1.45	1.31	0.94	0.48	0.48	0.48	0.39
2650-10-10-10-10	1.45	1.45	0.94	0.48	0.48	0.48	0.48
2650-10-10-10-10-FG	1.45	1.45	0.88	0.48	0.48	0.48	0.48

2650 UNION CROSS

(Con't)

SAE J514 070501
MS51517

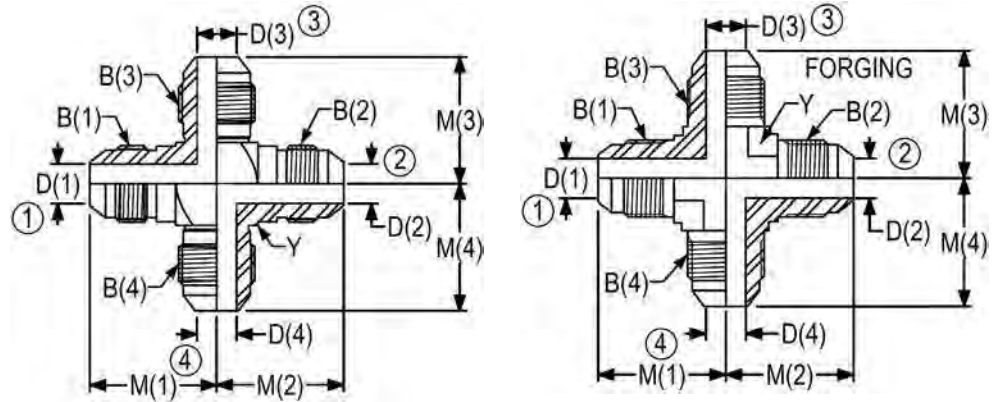

*Non forging parts are brazed construction

PART NO	TUBE OD	B (1) UN/UNF-2A	B (2) UN/UNF-2A	B (3) UN/UNF-2A	B (4) UN/UNF-2A	M (1)	M (2)
2650-12-08-08-08	3/4-1/2-1/2-1/2	1 1/16-12	3/4-16	3/4-16	3/4-16	1.66	1.40
2650-12-12-12-12	3/4-3/4-3/4-3/4	1 1/16-12	1 1/16-12	1 1/16-12	1 1/16-12	1.66	1.66
2650-12-12-12-12-FG	3/4-3/4-3/4-3/4	1 1/16-12	1 1/16-12	1 1/16-12	1 1/16-12	1.66	1.66
2650-14-14-14-14	7/8-7/8-7/8-7/8	1 3/16-12	1 3/16-12	1 3/16-12	1 3/16-12	1.80	1.80
2650-16-16-12-12	1-1-3/4-3/4	1 5/16-12	1 5/16-12	1 1/16-12	1 1/16-12	1.81	1.81
2650-16-16-16-16	1-1-1-1	1 5/16-12	1 5/16-12	1 5/16-12	1 5/16-12	1.81	1.81
2650-16-16-16-16-FG	1-1-1-1	1 5/16-12	1 5/16-12	1 5/16-12	1 5/16-12	1.81	1.81
2650-20-20-20-20	1 1/4-1 1/4-1 1/4-1 1/4	1 5/8-12	1 5/8-12	1 5/8-12	1 5/8-12	2.06	2.06
2650-24-24-24-24	1 1/2-1 1/2-1 1/2-1 1/2	1 7/8-14	1 7/8-14	1 7/8-14	1 7/8-14	2.33	2.33
2650-32-32-32-32	2-02-02-2	2 1/2-12	2 1/2-12	2 1/2-12	2 1/2-12	3.06	3.06

PART NO	M (3)	M (4)	Y	D (1)	D (2)	D (3)	D (4)
2650-12-08-08-08	1.40	1.40	1.13	0.61	0.39	0.39	0.39
2650-12-12-12-12	1.66	1.66	1.13	0.61	0.61	0.61	0.61
2650-12-12-12-12-FG	1.66	1.66	1.06	0.61	0.61	0.61	0.61
2650-14-14-14-14	1.80	1.80	1.25	0.72	0.72	0.72	0.72
2650-16-16-12-12	1.78	1.78	1.38	0.84	0.84	0.61	0.61
2650-16-16-16-16	1.81	1.81	1.38	0.84	0.84	0.84	0.84
2650-16-16-16-16-FG	1.81	1.81	1.31	0.84	0.84	0.84	0.84
2650-20-20-20-20	2.06	2.06	1.75	1.08	1.08	1.08	1.08
2650-24-24-24-24	2.33	2.33	2.00	1.31	1.31	1.31	1.31
2650-32-32-32-32	3.06	3.06	2.63	1.78	1.78	1.78	1.78

2651 MALE BRANCH CROSS

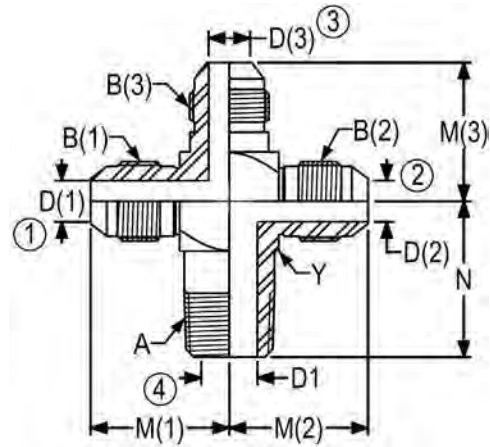

PART NO	TUBE OD	B (1) UN/UNF-2A	B (2) UN/UNF-2A	B (3) UN/UNF-2A	A NPTF	M (1)	M (2)	M (3)
2651-05-05-05-04	5/16-5/16-5/16	1/2-20	1/2-20	1/2-20	1/4-18	0.95	0.95	0.95
2651-06-06-06-04	3/8-3/8-3/8	9/16-18	9/16-18	9/16-18	1/4-18	1.06	1.06	1.06
2651-06-06-06-06	3/8-3/8-3/8	9/16-18	9/16-18	9/16-18	3/8-18	1.16	1.16	1.16
2651-08-08-08-06	1/2-1/2-1/2	3/4-16	3/4-16	3/4-16	3/8-18	1.25	1.25	1.25
2651-08-08-08-08	1/2-1/2-1/2	3/4-16	3/4-16	3/4-16	1/2-14	1.31	1.31	1.31
2651-12-12-12-12	3/4-3/4-3/4	1 1/16-12	1 1/16-12	1 1/16-12	3/4-14	1.66	1.66	1.66
2651-16-06-16-16	1-3/8-1	1 5/16-12	9/16-18	1 5/16-12	1-11 1/2	1.81	1.44	1.81
2651-16-12-12-16	1-3/4-3/4	1 5/16-12	1 1/16-12	1 1/16-12	1-11 1/2	1.81	1.78	1.78
2651-16-16-16-16	1-1-1	1 5/16-12	1 5/16-12	1 5/16-12	1-11 1/2	1.81	1.81	1.81

PART NO	N	Y	D (1)	D (2)	D (3)	D1
2651-05-05-05-04	1.06	0.56	0.23	0.23	0.23	0.28
2651-06-06-06-04	1.09	0.63	0.30	0.30	0.30	0.28
2651-06-06-06-06	1.22	0.81	0.30	0.30	0.30	0.41
2651-08-08-08-06	1.22	0.81	0.39	0.39	0.39	0.41
2651-08-08-08-08	1.47	0.94	0.39	0.39	0.39	0.53
2651-12-12-12-12	1.59	1.13	0.61	0.61	0.61	0.72
2651-16-06-16-16	1.97	1.38	0.84	0.30	0.84	0.94
2651-16-12-12-16	1.97	1.38	0.84	0.61	0.61	0.94
2651-16-16-16-16	1.97	1.38	0.84	0.84	0.84	0.94

2652 FEMALE BRANCH CROSS

INFORMATION AVAILABLE UPON REQUEST.
CALL CUSTOMER SERVICE FOR DETAILS.

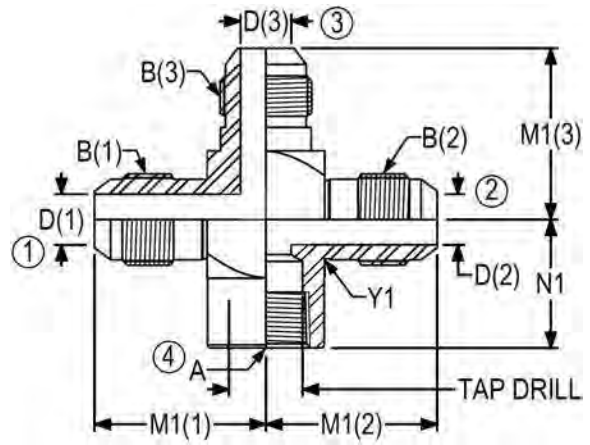

2653 MALE BRANCH/BRANCH CROSS

INFORMATION AVAILABLE UPON REQUEST.
CALL CUSTOMER SERVICE FOR DETAILS.

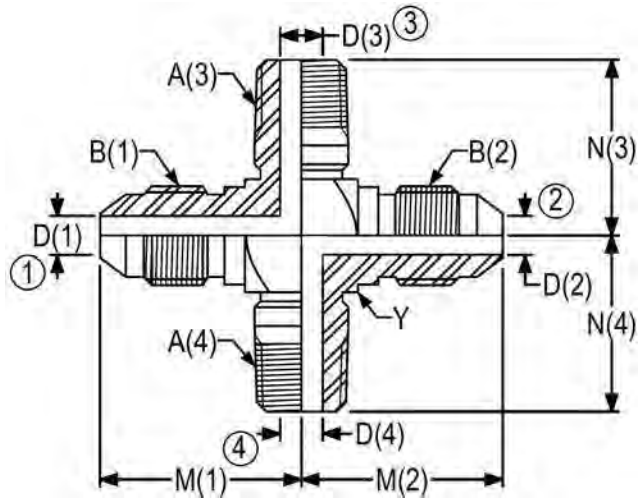

2654 MALE RUN/BRANCH CROSS

INFORMATION AVAILABLE UPON REQUEST.
CALL CUSTOMER SERVICE FOR DETAILS.

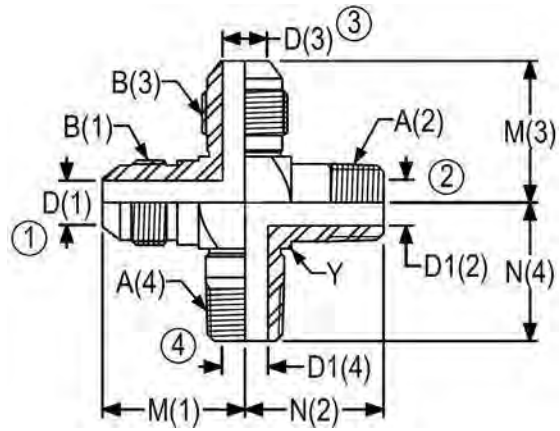

2658 FEMALE RUN/BRANCH/BRANCH CROSS

INFORMATION AVAILABLE UPON REQUEST.
CALL CUSTOMER SERVICE FOR DETAILS.

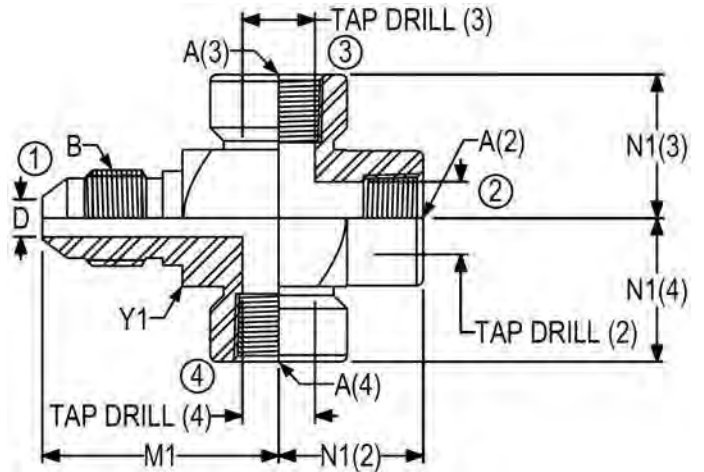

2700-LN BULKHEAD UNION

SAE J514 070601
MS51520

BASE PART DOES NOT INCLUDE LOCKNUT.
TO ORDER WITH LOCKNUT, ADD -LN TO PART
NUMBER.

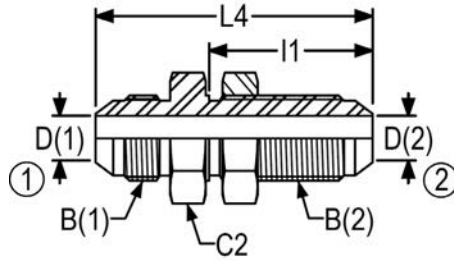

PART NO	TUBE OD	B (1) UN/UNF-2A	B (2) UN/UNF-2A	L4	I1	C2	D (1)	D (2)
2700-02-02-LN	1/8-1/8	5/16-24	5/16-24	1.87	1.11	0.56	0.08	0.08
2700-04-04-LN	1/4-1/4	7/16-20	7/16-20	2.07	1.20	0.69	0.17	0.17
2700-05-05-LN	5/16-5/16	1/2-20	1/2-20	2.07	1.20	0.75	0.23	0.23
2700-05-06-LN	5/16-3/8	1/2-20	9/16-18	2.17	1.28	0.81	0.23	0.30
2700-06-04-LN	3/8-1/4	9/16-18	7/16-20	2.10	1.20	0.69	0.30	0.17
2700-06-06-LN	3/8-3/8	9/16-18	9/16-18	2.18	1.28	0.81	0.30	0.30
2700-08-08-LN	1/2-1/2	3/4-16	3/4-16	2.44	1.44	1.00	0.39	0.39
2700-10-10-LN	5/8-5/8	7/8-14	7/8-14	2.74	1.58	1.13	0.48	0.48
2700-12-12-LN	3/4-3/4	1 1/16-12	1 1/16-12	3.09	1.75	1.38	0.61	0.61
2700-14-14-LN	7/8-7/8	1 3/16-12	1 3/16-12	3.12	1.75	1.50	0.72	0.72
2700-16-12-LN	1-3/4	1 5/16-12	1 1/16-12	3.14	1.75	1.63	0.84	0.61
2700-16-16-LN	1-1	1 5/16-12	1 5/16-12	3.14	1.75	1.63	0.84	0.84
2700-20-20-LN	1 1/4-1 1/4	1 5/8-12	1 5/8-12	3.31	1.80	1.88	1.08	1.08
2700-24-24-LN	1 1/2-1 1/2	1 7/8-12	1 7/8-12	3.52	1.81	2.13	1.31	1.31

**2701-LN 90 DEGREE BULKHEAD
ELBOW**

SAE J514 070701
MS51507

BASE PART DOES NOT INCLUDE LOCKNUT.
TO ORDER WITH LOCKNUT, ADD -LN TO
PART

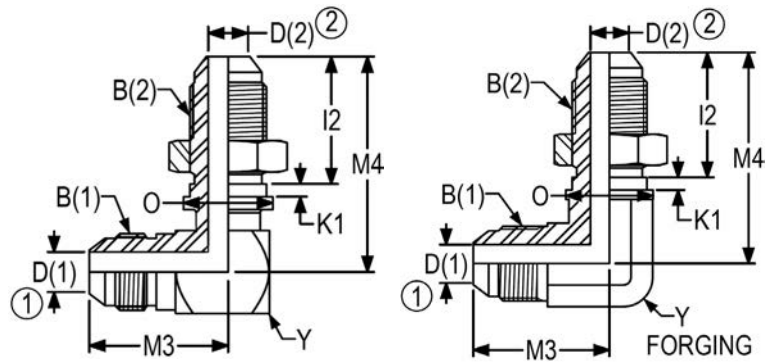

*Non forging parts are brazed construction

PART NO	TUBE OD	B (1) UN/UNF-2A	B (2) UN/UNF-2A	M3	M4	I2	K1	O	Y	D (1)	D (2)
2701-02-02-LN	1/8-1/8	5/16-24	5/16-24	0.88	1.50	0.92	0.09	0.44	0.44	0.06	0.06
2701-04-04-LN	1/4-1/4	7/16-20	7/16-20	0.97	1.59	1.02	0.09	0.56	0.50	0.17	0.17
2701-04-04-LN-FG	1/4-1/4	7/16-20	7/16-20	0.97	1.59	1.02	0.09	0.56	0.44	0.17	0.17
2701-05-05-LN	5/16-5/16	1/2-20	1/2-20	1.03	1.61	1.02	0.09	0.63	0.56	0.23	0.23
2701-05-05-LN-FG	5/16-5/16	1/2-20	1/2-20	1.06	1.72	1.02	0.09	0.63	0.56	0.23	0.23
2701-06-05-LN	3/8-5/16	9/16-18	1/2-20	1.09	1.64	1.02	0.09	0.63	0.63	0.30	0.23
2701-06-06-LN	3/8-3/8	9/16-18	9/16-18	1.09	1.81	1.09	0.09	0.69	0.63	0.30	0.30
2701-06-06-LN-FG	3/8-3/8	9/16-18	9/16-18	1.09	1.81	1.09	0.09	0.56	0.56	0.30	0.30
2701-08-06-LN	1/2-3/8	3/4-16	9/16-18	1.36	1.91	1.09	0.09	0.69	0.81	0.39	0.30
2701-08-08-LN	1/2-1/2	3/4-16	3/4-16	1.36	2.11	1.25	0.13	0.88	0.81	0.39	0.39
2701-08-08-LN-FG	1/2-1/2	3/4-16	3/4-16	1.36	2.11	1.25	0.09	0.88	0.75	0.39	0.39
2701-10-08-LN-FG	5/8-1/2	7/8-14	3/4-16	1.56	2.27	1.25	0.13	0.88	0.88	0.48	0.39
2701-10-10-LN	5/8-5/8	7/8-14	7/8-14	1.56	2.39	1.39	0.13	1.00	0.94	0.48	0.48
2701-10-10-LN-FG	5/8-5/8	7/8-14	7/8-14	1.56	2.39	1.39	0.13	0.88	0.88	0.48	0.48
2701-12-10-LN	3/4-5/8	1 1/16-12	7/8-14	1.78	2.47	1.39	0.13	1.00	1.13	0.61	0.48
2701-12-12-LN	3/4-3/4	1 1/16-12	1 1/16-12	1.78	2.67	1.56	0.13	1.19	1.13	0.61	0.61
2701-12-12-LN-FG	3/4-3/4	1 1/16-12	1 1/16-12	1.78	2.67	1.56	0.13	1.06	1.06	0.61	0.61
2701-16-16-LN	1-1	1 5/16-12	1 5/16-12	1.94	2.80	1.56	0.13	1.44	1.38	0.84	0.84
2701-16-16-LN-FG	1-1	1 5/16-12	1 5/16-12	1.94	2.80	1.56	0.13	1.30	1.31	0.84	0.84
2701-20-20-LN	1 1/4-1 1/4	1 5/8-12	1 5/8-12	2.17	3.12	1.61	0.13	1.75	1.75	1.08	1.08
2701-20-20-LN-FG	1 1/4-1 1/4	1 5/8-12	1 5/8-12	2.17	3.12	1.61	0.13	1.62	1.63	1.08	1.08
2701-24-24-LN	1 1/2-1 1/2	1 7/8-12	1 7/8-12	2.34	3.42	1.62	0.13	2.00	2.00	1.31	1.31
2701-32-32-LN	2-2	2 1/2-12	2 1/2-12	2.89	4.11	1.91	0.13	2.63	2.63	1.78	1.78

**2702-LN 45 DEGREE BULKHEAD
ELBOW**

SAE J514 070801
MS51509

BASE PART DOES NOT INCLUDE LOCKNUT.
TO ORDER WITH LOCKNUT, ADD -LN TO
PART NUMBER

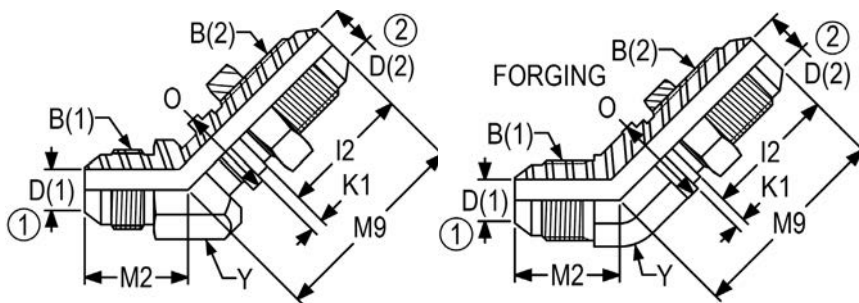

*Non forging parts are brazed construction

PART NO	TUBE OD	B (1) UN/UNF-2A	B (2) UN/UNF-2A	M2	M9	I2	K1	O	Y	D (1)	D (2)
2702-02-02-LN	1/8-1/8	5/16-24	5/16-24	0.69	1.42	0.92	0.09	0.44	0.44	0.06	0.06
2702-04-04-LN	1/4-1/4	7/16-20	7/16-20	0.72	1.53	1.02	0.09	0.56	0.50	0.17	0.17
2702-04-04-LN-FG	1/4-1/4	7/16-20	7/16-20	0.72	1.53	1.02	0.09	0.56	0.44	0.17	0.17
2702-05-05-LN	5/16-5/16	1/2-20	1/2-20	0.80	1.53	1.02	0.09	0.63	0.56	0.23	0.23
2702-05-05-LN-FG	5/16-5/16	1/2-20	1/2-20	0.77	1.66	1.02	0.09	0.63	0.56	0.23	0.23
2702-06-06-LN	3/8-3/8	9/16-18	9/16-18	0.83	1.67	1.09	0.09	0.69	0.63	0.30	0.30
2702-06-06-LN-FG	3/8-3/8	9/16-18	9/16-18	0.83	1.67	1.09	0.09	0.69	0.56	0.30	0.30
2702-08-08-LN	1/2-1/2	3/4-16	3/4-16	0.98	1.94	1.25	0.13	0.88	0.81	0.39	0.39
2702-08-08-LN-FG	1/2-1/2	3/4-16	3/4-16	0.98	1.94	1.25	0.09	0.88	0.75	0.39	0.39
2702-10-10-LN	5/8-5/8	7/8-14	7/8-14	1.11	2.17	1.39	0.13	1.00	0.94	0.48	0.48
2702-10-10-LN-FG	5/8-5/8	7/8-14	7/8-14	1.11	2.17	1.39	0.13	1.00	0.88	0.48	0.48
2702-12-12-LN	3/4-3/4	1 1/16-12	1 1/16-12	1.28	2.44	1.56	0.13	1.19	1.13	0.61	0.61
2702-12-12-LN-FG	3/4-3/4	1 1/16-12	1 1/16-12	1.28	2.44	1.56	0.13	1.19	1.06	0.61	0.61
2702-14-14-LN	7/8-7/8	1 3/16-12	1 3/16-12	1.39	2.50	1.56	0.13	1.31	1.25	0.72	0.72
2702-16-16-LN	1-1	1 5/16-12	1 5/16-12	1.47	2.53	1.56	0.13	1.44	1.38	0.84	0.84
2702-16-16-LN-FG	1-1	1 5/16-12	1 5/16-12	1.47	2.56	1.56	0.13	1.44	1.31	0.84	0.84
2702-20-20-LN	1 1/4-1 1/4	1 5/8-12	1 5/8-12	1.59	2.65	1.61	0.13	1.75	1.75	1.08	1.08
2702-24-24-LN	1 1/2-1 1/2	1 7/8-12	1 7/8-12	1.78	2.67	1.62	0.13	2.00	2.00	1.31	1.31

2703-LN BULKHEAD BRANCH TEE

SAE J514 070959
MS51515

BASE PART DOES NOT INCLUDE LOCKNUT.
TO ORDER WITH LOCKNUT, ADD -LN TO
PART NUMBER

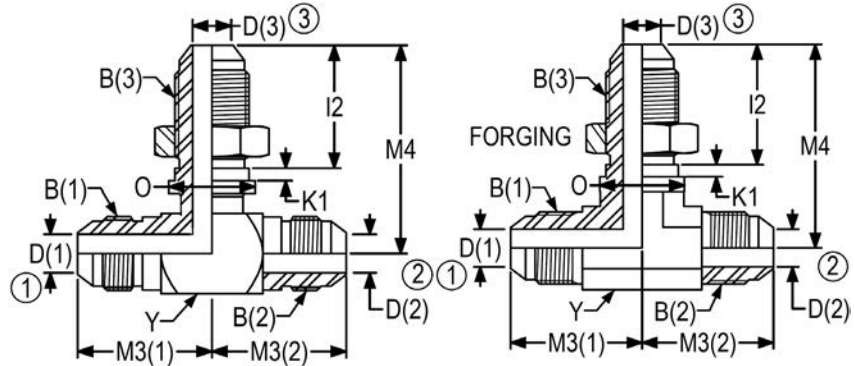

*Non forging parts are brazed construction

PART NO	TUBE OD	B (1) UN/UNF-2A	B (2) UN/UNF-2A	B (3) UN/UNF-2A	M3 (1)	M3 (2)	M4	I2
2703-04-04-04-LN	1/4-1/4-1/4	7/16-20	7/16-20	7/16-20	0.97	0.97	1.59	1.02
2703-04-04-04-LN-FG	1/4-1/4-1/4	7/16-20	7/16-20	7/16-20	0.97	0.97	1.59	1.02
2703-05-05-05-LN	5/16-5/16-5/16	1/2-20	1/2-20	1/2-20	1.06	1.06	1.61	1.02
2703-06-06-06-LN	3/8-3/8-3/8	9/16-18	9/16-18	9/16-18	1.09	1.09	1.81	1.09
2703-06-06-06-LN-FG	3/8-3/8-3/8	9/16-18	9/16-18	9/16-18	1.09	1.09	1.81	1.09
2703-08-08-08-LN	1/2-1/2-1/2	3/4-16	3/4-16	3/4-16	1.36	1.36	2.11	1.25
2703-08-08-08-LN-FG	1/2-1/2-1/2	3/4-16	3/4-16	3/4-16	1.36	1.36	2.11	1.25
2703-10-10-10-LN	5/8-5/8-5/8	7/8-14	7/8-14	7/8-14	1.56	1.56	2.39	1.39
2703-10-10-10-LN-FG	5/8-5/8-5/8	7/8-14	7/8-14	7/8-14	1.56	1.56	2.39	1.39
2703-12-12-12-LN	3/4-3/4-3/4	1 1/16-12	1 1/16-12	1 1/16-12	1.78	1.78	2.67	1.56
2703-12-12-12-LN-FG	3/4-3/4-3/4	1 1/16-12	1 1/16-12	1 1/16-12	1.78	1.78	2.67	1.56
2703-16-16-16-LN	1-1-1	1 5/16-12	1 5/16-12	1 5/16-12	1.94	1.94	2.80	1.56
2703-16-16-16-LN-FG	1-1-1	1 5/16-12	1 5/16-12	1 5/16-12	1.94	1.94	2.80	1.56
2703-20-20-20-LN	1 1/4-1 1/4-1 1/4	1 5/8-12	1 5/8-12	1 5/8-12	2.17	2.17	3.12	1.61
2703-24-24-24-LN	1 1/2-1 1/2-1 1/2	1 7/8-12	1 7/8-12	1 7/8-12	2.34	2.34	3.42	1.62

PART NO	K1	O	Y	D (1)	D (2)	D (3)
2703-04-04-04-LN	0.09	0.56	0.50	0.17	0.17	0.17
2703-04-04-04-LN-FG	0.09	0.56	0.44	0.17	0.17	0.17
2703-04-04-06-LN	0.09	0.69	0.63	0.17	0.17	0.30
2703-05-05-05-LN	0.09	0.63	0.56	0.23	0.23	0.23
2703-06-06-06-LN	0.09	0.69	0.63	0.30	0.30	0.30
2703-06-06-06-LN-FG	0.09	0.69	0.56	0.30	0.30	0.30
2703-08-08-08-LN	0.13	0.88	0.81	0.39	0.39	0.39
2703-08-08-08-LN-FG	0.09	0.88	0.75	0.39	0.39	0.39
2703-10-10-10-LN	0.13	1.00	0.94	0.48	0.48	0.48
2703-10-10-10-LN-FG	0.13	0.87	0.88	0.48	0.48	0.48
2703-12-12-12-LN	0.13	1.19	1.13	0.61	0.61	0.61
2703-12-12-12-LN-FG	0.13	1.19	1.06	0.61	0.61	0.61
2703-16-16-16-LN	0.13	1.44	1.38	0.84	0.84	0.84
2703-16-16-16-LN-FG	0.13	1.44	1.31	0.84	0.84	0.84
2703-20-20-20-LN	0.13	1.75	1.75	1.08	1.08	1.08
2703-24-24-24-LN	0.13	2.00	2.00	1.31	1.31	1.31

2704-LN BULKHEAD RUN TEE

SAE J514 070958
MS51516

BASE PART DOES NOT INCLUDE
LOCKNUT. TO ORDER WITH LOCKNUT,
ADD -LN TO PART NUMBER

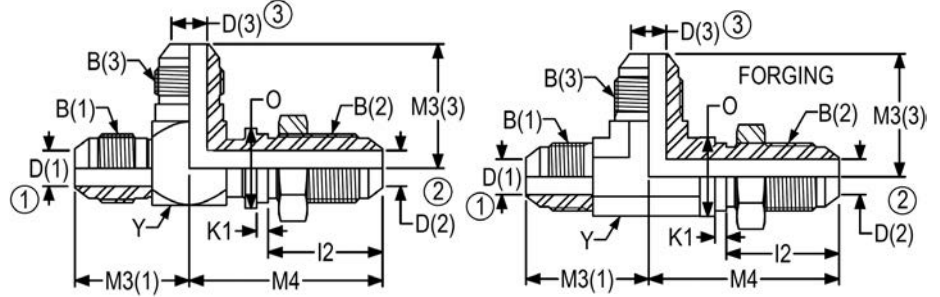

*Non forging parts are brazed construction

PART NO	TUBE OD	B (1) UN/UNF-2A	B (2) UN/UNF-2A	B (3) UN/UNF-2A	M3 (1)	M4	M3 (3)	I2
2704-04-04-04-LN	1/4-1/4-1/4	7/16-20	7/16-20	7/16-20	0.89	1.59	0.97	1.02
2704-04-04-04-LN-FG	1/4-1/4-1/4	7/16-20	7/16-20	7/16-20	0.97	1.59	0.97	1.02
2704-06-06-06-LN	3/8-3/8-3/8	9/16-18	9/16-18	9/16-18	1.06	1.81	1.09	1.09
2704-06-06-06-LN-FG	3/8-3/8-3/8	9/16-18	9/16-18	9/16-18	1.09	1.81	1.09	1.09
2704-08-08-08-LN	1/2-1/2-1/2	3/4-16	3/4-16	3/4-16	1.25	2.11	1.36	1.25
2704-08-08-08-LN-FG	1/2-1/2-1/2	3/4-16	3/4-16	3/4-16	1.36	2.11	1.36	1.25
2704-08-10-08-LN	1/2-5/8-1/2	3/4-16	7/8-14	3/4-16	1.31	2.39	1.31	1.39
2704-10-10-10-LN	5/8-5/8-5/8	7/8-14	7/8-14	7/8-14	1.55	2.39	1.56	1.39
2704-10-10-10-LN-FG	5/8-5/8-5/8	7/8-14	7/8-14	7/8-14	1.56	2.39	1.56	1.39
2704-12-12-12-LN	3/4-3/4-3/4	1 1/16-12	1 1/16-12	1 1/16-12	1.78	2.67	1.78	1.56
2704-12-12-12-LN-FG	3/4-3/4-3/4	1 1/16-12	1 1/16-12	1 1/16-12	1.78	2.67	1.78	1.56
2704-12-12-16-LN	3/4-3/4-1	1 1/16-12	1 1/16-12	1 5/16-12	1.89	2.8	1.94	1.56
2704-16-12-12-LN	1-3/4-3/4	1 5/16-12	1 1/16-12	1 1/16-12	1.81	2.80	1.78	1.56
2704-16-16-16-LN	1-1-1	1 5/16-12	1 5/16-12	1 5/16-12	1.81	2.80	1.94	1.56
2704-16-16-16-LN-FG	1-1-1	1 5/16-12	1 5/16-12	1 5/16-12	1.94	2.80	1.94	1.56
2704-20-20-20-LN	1 1/4-1 1/4-1 1/4	1 5/8-12	1 5/8-12	1 5/8-12	2.06	3.12	2.17	1.61
2704-24-24-24-LN	1 1/2-1 1/2-1 1/2	1 7/8-12	1 7/8-12	1 7/8-12	2.34	3.42	2.34	1.62

PART NO	K1	O	Y	D (1)	D (2)	D (3)
2704-04-04-04-LN	0.09	0.56	0.50	0.17	0.17	0.17
2704-04-04-04-LN-FG	0.09	0.56	0.44	0.17	0.17	0.17
2704-06-06-06-LN	0.09	0.69	0.63	0.30	0.30	0.30
2704-06-06-06-LN-FG	0.09	0.69	0.56	0.30	0.30	0.30
2704-08-08-08-LN	0.13	0.88	0.81	0.39	0.39	0.39
2704-08-08-08-LN-FG	0.13	0.88	0.75	0.39	0.39	0.39
2704-08-10-08-LN	0.13	1.00	0.94	0.39	0.48	0.39
2704-10-10-10-LN	0.13	1.00	0.94	0.48	0.48	0.48
2704-10-10-10-LN-FG	0.13	1.00	0.88	0.48	0.48	0.48
2704-12-12-12-LN	0.13	1.19	1.13	0.61	0.61	0.61
2704-12-12-12-LN-FG	0.13	1.19	1.06	0.61	0.61	0.61
2704-12-12-16-LN	0.13	1.19	1.38	0.61	0.61	0.84
2704-16-12-12-LN	0.13	1.19	1.38	0.84	0.61	0.61
2704-16-16-16-LN	0.13	1.44	1.38	0.84	0.84	0.84
2704-16-16-16-LN-FG	0.13	1.44	1.31	0.84	0.84	0.84
2704-20-20-20-LN	0.13	1.75	1.75	1.08	1.08	1.08
2704-24-24-24-LN	0.13	2.00	2.00	1.31	1.31	1.31

2705-LN FEMALE PIPE/BULKHEAD CONNECTOR

BASE PART DOES NOT INCLUDE LOCKNUT.
TO ORDER WITH LOCKNUT, ADD -LN TO PART NUMBER

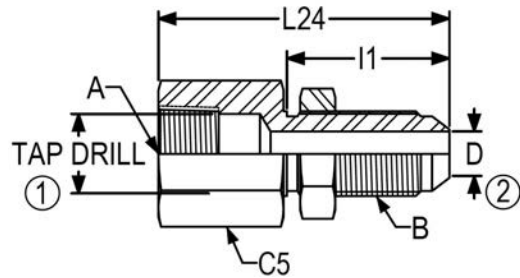

PART NO	TUBE OD	A NPTF	B UN/UNF-2A	L24	I1	C5	TAP DRILL	D
2705-02-04-LN	1/4	1/8-27	7/16-20	1.84	1.20	0.69	0.33	0.17
2705-04-04-LN	1/4	1/4-18	7/16-20	2.00	1.20	0.75	0.43	0.17
2705-04-06-LN	3/8	1/4-18	9/16-18	2.08	1.28	0.81	0.43	0.30
2705-06-06-LN	3/8	3/8-18	9/16-18	2.18	1.28	1.00	0.57	0.30
2705-06-08-LN	1/2	3/8-18	3/4-16	2.34	1.44	1.00	0.57	0.39
2705-08-08-LN	1/2	1/2-14	3/4-16	2.58	1.44	1.13	0.70	0.39
2705-08-10-LN	5/8	1/2-14	7/8-14	2.66	1.58	1.13	0.70	0.48
2705-12-12-LN	3/4	3/4-14	1 1/16-12	2.92	1.75	1.38	0.91	0.61
2705-16-16-LN	1	1-11 1/2	1 5/16-12	3.09	1.75	1.63	1.14	0.84
2705-20-20-LN	1 1/4	1 1/4-11 1/2	1 5/8-12	3.22	1.61	2.00	1.48	1.08
2705-24-24-LN	1 1/2	1 1/2-11 1/2	1 7/8-12	3.33	1.84	2.38	1.72	1.31

2706-LN MALE PIPE/BULKHEAD CONNECTOR

BASE PART DOES NOT INCLUDE LOCKNUT.
TO ORDER WITH LOCKNUT, ADD -LN TO PART NUMBER

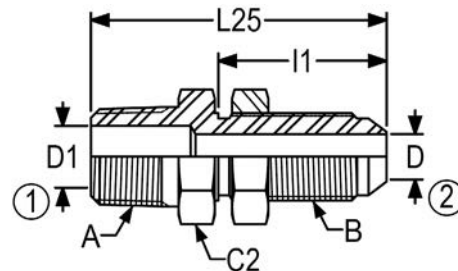

PART NO	TUBE OD	A NPTF	B UN/UNF-2A	L25	I1	C2	D1	D
2706-02-04-LN	1/4	1/8-27	7/16-20	1.84	1.20	0.69	0.19	0.17
2706-04-04-LN	1/4	1/4-18	7/16-20	2.03	1.20	0.69	0.28	0.17
2706-04-06-LN	3/8	1/4-18	9/16-18	2.19	1.28	0.81	0.28	0.30
2706-06-06-LN	3/8	3/8-18	9/16-18	2.19	1.28	0.81	0.41	0.30
2706-06-08-LN	1/2	3/8-18	3/4-16	2.36	1.44	1.00	0.41	0.39
2706-08-08-LN	1/2	1/2-14	3/4-16	2.53	1.44	1.00	0.53	0.39
2706-08-10-LN	5/8	1/2-14	7/8-14	2.72	1.58	1.13	0.53	0.48
2706-08-12-LN	3/4	1/2-14	1 1/16-12	2.93	1.75	1.38	0.53	0.61
2706-12-12-LN	3/4	3/4-14	1 1/16-12	2.92	1.75	1.38	0.72	0.61
2706-16-16-LN	1	1-11 1/2	1 5/16-12	3.11	1.75	1.63	0.94	0.84
2706-20-20-LN	1 1/4	1 1/4-11	1 5/8-12	3.25	1.80	1.88	1.25	1.08
2706-24-24-LN	1 1/2	1 1/2-11	1 7/8-12	3.44	1.81	2.13	1.50	1.31

**4305 BARBED HOSE/SWIVEL
CONNECTOR**

*C=Round Stock Size

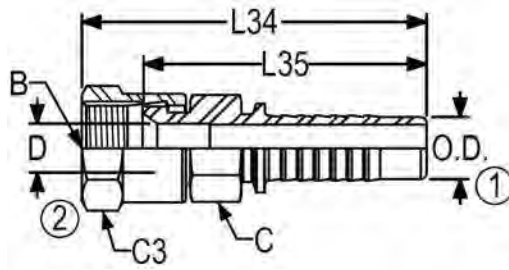

PART NO	TUBE OD	B UN/UNF-2B	L34	L35	C	C3	D1	D
4305-04-04	1/4	7/16-20	2.26	1.90	0.44	0.56	0.16	0.17
4305-04-06	1/4	9/16-18	2.40	2.01	0.56	0.69	0.16	0.30
4305-06-06	3/8	9/16-18	2.49	2.10	0.56	0.69	0.28	0.30
4305-06-08	3/8	3/4-16	2.59	2.11	0.69	0.88	0.28	0.39
4305-08-06	1/2	9/16-18	2.62	2.23	0.75	0.69	0.38	0.30
4305-08-08	1/2	3/4-16	2.78	2.29	0.75	0.88	0.38	0.39
4305-08-10	1/2	7/8-14	2.92	2.43	0.81	1.00	0.38	0.48
4305-12-12	3/4	1 1/16-12	3.38	2.82	1.00	1.25	0.57	0.61
4305-16-16	1	1 5/16-12	4.12	3.53	1.25	1.50	0.78	0.84
4305-20-20*	1 1/4	1 5/8-12	3.26	2.63	1.63	2.00	1.08	1.08
4305-24-24*	1 1/2	1 7/8-12	3.63	2.91	2.00	2.25	1.31	1.31
4305-32-32*	2	2 1/2-12	4.14	3.19	2.50	2.88	1.66	1.66

6500 90 DEGREE SWIVEL ELBOW

SAE J514 070221
MS51521

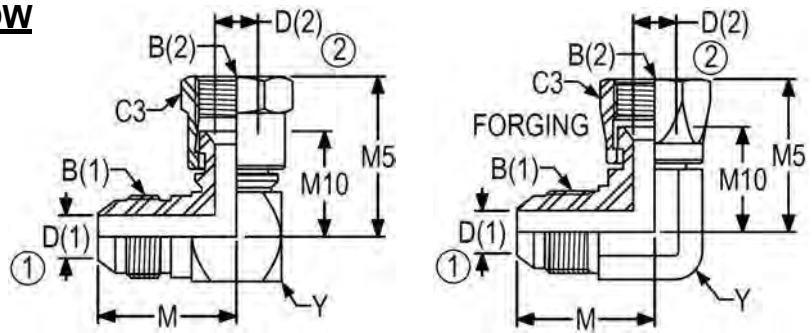

*Non forging parts are brazed construction

PART NO	TUBE OD	B (1) UN/UNF-2A	B (2) UN/UNF-2B	M	M5	M10	C3	Y	D (1)	D (2)
6500-03-03-FG	3/16-3/16	3/8-24	3/8-24	0.83	0.96	0.64	0.56	0.44	0.13	0.13
6500-04-04	1/4-1/4	7/16-20	7/16-20	0.89	1.00	0.66	0.56	0.50	0.17	0.17
6500-04-04-FG	1/4-1/4	7/16-20	7/16-20	0.89	1.00	0.66	0.56	0.44	0.17	0.17
6500-04-06	1/4-3/8	7/16-20	9/16-18	0.95	1.25	0.88	0.69	0.63	0.17	0.30
6500-05-05	5/16-5/16	1/2-20	1/2-20	0.95	1.06	0.69	0.63	0.56	0.23	0.23
6500-05-05-FG	5/16-5/16	1/2-20	1/2-20	0.95	1.06	0.69	0.63	0.56	0.23	0.23
6500-05-06	5/16-3/8	1/2-20	9/16-18	0.95	1.22	0.84	0.69	0.56	0.23	0.30
6500-06-04	3/8-1/4	9/16-18	7/16-20	1.06	1.06	0.72	0.56	0.63	0.30	0.17
6500-06-05	3/8-5/16	9/16-18	1/2-20	1.06	1.09	0.72	0.63	0.63	0.30	0.23
6500-06-06	3/8-3/8	9/16-18	9/16-18	1.06	1.25	0.88	0.69	0.63	0.30	0.30
6500-06-06-FG	3/8-3/8	9/16-18	9/16-18	1.06	1.25	0.88	0.69	0.56	0.30	0.30
6500-06-08	3/8-1/2	9/16-18	3/4-16	1.16	1.38	0.96	0.88	0.81	0.30	0.39
6500-06-08-FG	3/8-1/2	9/16-18	3/4-16	1.14	1.38	0.96	0.88	0.75	0.30	0.39
6500-08-06	1/2-3/8	3/4-16	9/16-18	1.25	1.35	0.97	0.69	0.81	0.39	0.30
6500-08-06-FG	1/2-3/8	3/4-16	9/16-18	1.25	1.33	0.95	0.69	0.75	0.39	0.30
6500-08-08	1/2-1/2	3/4-16	3/4-16	1.25	1.38	0.96	0.88	0.81	0.39	0.39
6500-08-08-FG	1/2-1/2	3/4-16	3/4-16	1.25	1.38	0.96	0.88	0.75	0.39	0.39
6500-08-10	1/2-5/8	3/4-16	7/8-14	1.31	1.62	1.12	1.00	0.94	0.39	0.48
6500-08-10-FG	1/2-5/8	3/4-16	7/8-14	1.33	1.62	1.12	1.00	0.88	0.39	0.48
6500-08-12	1/2-3/4	3/4-16	1 1/16-12	1.41	1.75	1.19	1.25	1.13	0.39	0.61
6500-08-12-FG	1/2-3/4	3/4-16	1 1/16-12	1.42	1.75	1.19	1.25	1.06	0.39	0.85
6500-10-08	5/8-1/2	7/8-14	3/4-16	1.45	1.44	1.02	0.88	0.94	0.48	0.39
6500-10-08-FG	5/8-1/2	7/8-14	3/4-16	1.45	1.51	1.09	0.88	0.88	0.48	0.39
6500-10-10	5/8-5/8	7/8-14	7/8-14	1.45	1.62	1.12	1.00	0.94	0.48	0.48
6500-10-10-FG	5/8-5/8	7/8-14	7/8-14	1.45	1.62	1.12	1.00	0.88	0.48	0.48

6500 90 DEGREE SWIVEL ELBOW

(Con't)

SAE J514 070221

MS51521

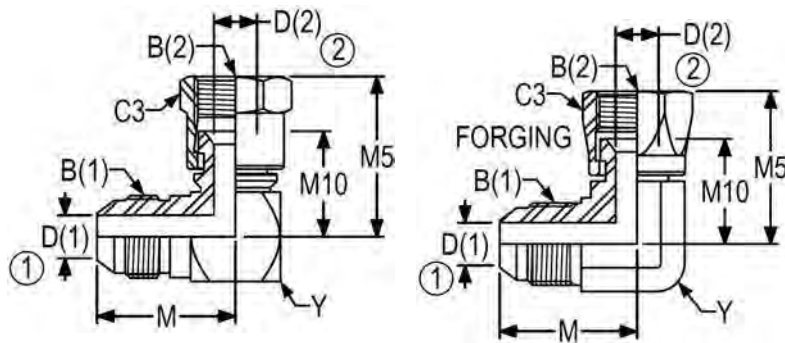

*Non forging parts are brazed construction

PART NO	TUBE OD	B (1) UN/UNF-2A	B (2) UN/UNF-2B	M	M5	M10	C3	Y	D (1)	D (2)
6500-10-12	5/8-3/4	7/8-14	1 1/16-12	1.55	1.75	1.19	1.25	1.13	0.48	0.61
6500-10-12-FG	5/8-3/4	7/8-14	1 1/16-12	1.54	1.75	1.19	1.25	1.06	0.48	0.61
6500-12-08	3/4-1/2	1 1/16-12	3/4-16	1.66	1.53	1.11	0.88	1.13	0.61	0.39
6500-12-10	3/4-5/8	1 1/16-12	7/8-14	1.66	1.71	1.21	1.00	1.13	0.61	0.48
6500-12-10-FG	3/4-5/8	1 1/16-12	7/8-14	1.66	1.69	1.19	1.00	1.06	0.61	0.48
6500-12-12	3/4-3/4	1 1/16-12	1 1/16-12	1.66	1.75	1.19	1.25	1.13	0.61	0.61
6500-12-12-FG	3/4-3/4	1 1/16-12	1 1/16-12	1.66	1.75	1.19	1.25	1.06	0.61	0.61
6500-12-16	3/4-1	1 1/16-12	1 5/16-12	1.78	2.00	1.41	1.50	1.38	0.61	0.84
6500-14-14	7/8-7/8	1 3/16-12	1 3/16-12	1.80	1.78	1.22	1.38	1.25	0.72	0.72
6500-14-14-FG	7/8-7/8	1 3/16-12	1 3/16-12	1.80	1.81	1.23	1.38	1.31	0.72	0.72
6500-16-12	1-3/4	1 5/16-12	1 1/16-12	1.81	1.88	1.31	1.25	1.38	0.84	0.61
6500-16-16	1-1	1 5/16-12	1 5/16-12	1.81	2.00	1.41	1.50	1.38	0.84	0.84
6500-16-16-FG	1-1	1 5/16-12	1 5/16-12	1.81	2.00	1.41	1.50	1.31	0.84	0.84
6500-16-20	1-1 1/4	1 5/16-12	1 5/8-12	2.00	2.31	1.68	2.00	1.75	0.84	1.08
6500-20-20	1 1/4-1 1/4	1 5/8-12	1 5/8-12	2.06	2.31	1.68	2.00	1.75	1.08	1.08
6500-20-20-FG	1 1/4-1 1/4	1 5/8-12	1 5/8-12	2.06	2.31	1.69	2.00	1.62	1.08	1.08
6500-24-20	1 1/2-1 1/4	1 7/8-12	1 5/8-12	2.33	2.44	1.81	2.00	2.00	1.31	1.08
6500-24-24	1 1/2-1 1/2	1 7/8-12	1 7/8-12	2.33	2.59	1.86	2.25	2.00	1.31	1.31
6500-24-24-FG	1 1/2-1 1/2	1 7/8-12	1 7/8-12	2.33	2.59	1.86	2.25	1.88	1.31	1.31
6500-32-32	2-2	2 1/2-12	2 1/2-12	3.06	3.38	2.44	2.88	2.63	1.78	1.78
6500-32-32-FG	2-2	2 1/2-12	2 1/2-12	3.06	3.38	2.44	2.88	2.50	1.78	1.78

6500-L 90 DEGREE LONG SWIVEL ELBOW

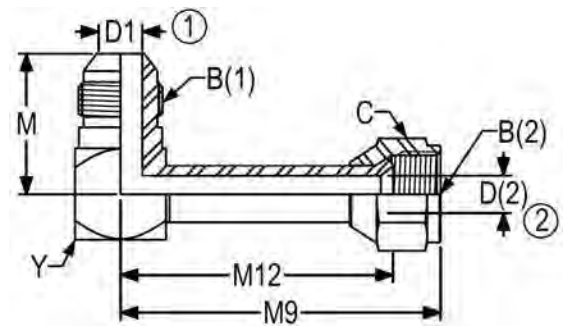

PART NO	TUBE OD	B (1) UN/UNF-2A	B (2) UN/UNF-2B	M	M9	M12	C	Y	D (1)	D (2)
6500-L-04-04	1/4	7/16-20	7/16-20	0.89	2.17	1.80	0.56	0.50	0.17	0.12
6500-L-06-06	3/8	9/16-18	9/16-18	1.06	2.54	2.18	0.69	0.63	0.30	0.25
6500-L-08-08	1/2	3/4-16	3/4-16	1.25	2.87	2.43	0.88	0.81	0.39	0.33
6500-L-10-10	5/8	7/8-14	7/8-14	1.45	3.03	2.57	1.00	0.94	0.48	0.46
6500-L-12-12	3/4	1 1/16-12	1 1/16-12	1.66	4.31	3.73	1.25	1.13	0.61	0.58
6500-L-16-16	1	1 5/16-12	1 5/16-12	1.81	4.94	4.33	1.50	1.38	0.84	0.81

**6501 90 DEGREE MALE PIPE/SWIVEL
ELBOW**

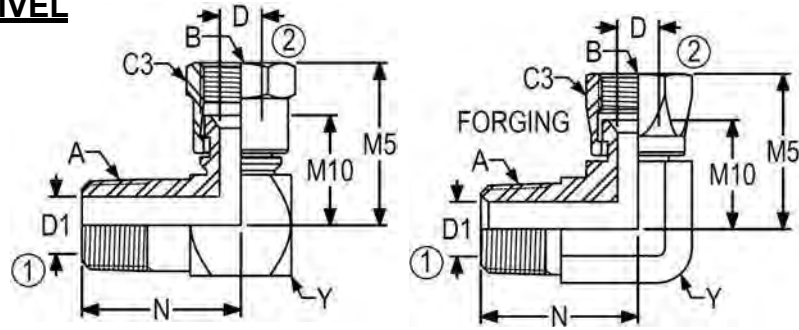

*Non forging parts are brazed construction

PART NO	TUBE OD	A NPTF	B UN/UNF-2B	N	M5	M10	C3	Y	D1	D
6501-02-04	1/4	1/8-27	7/16-20	0.78	1.00	0.66	0.56	0.50	0.19	0.17
6501-02-04-FG	1/4	1/8-27	7/16-20	0.78	1.00	0.66	0.56	0.44	0.19	0.17
6501-02-05	5/16	1/8-27	1/2-20	0.78	1.03	0.66	0.63	0.50	0.19	0.23
6501-04-04	1/4	1/4-18	7/16-20	1.09	1.06	0.72	0.56	0.63	0.28	0.17
6501-04-04-FG	1/4	1/4-18	7/16-20	1.09	1.11	0.77	0.56	0.56	0.28	0.17
6501-04-05	5/16	1/4-18	1/2-20	1.09	1.09	0.72	0.63	0.63	0.28	0.23
6501-04-06	3/8	1/4-18	9/16-18	1.09	1.25	0.88	0.69	0.63	0.28	0.30
6501-06-06	3/8	3/8-18	9/16-18	1.22	1.34	0.97	0.69	0.81	0.41	0.30
6501-06-08	1/2	3/8-18	3/4-16	1.22	1.38	0.96	0.88	0.81	0.41	0.39
6501-08-06	3/8	1/2-14	9/16-18	1.47	1.41	1.03	0.69	0.94	0.53	0.30
6501-08-08	1/2	1/2-14	3/4-16	1.47	1.44	1.02	0.88	0.94	0.53	0.39
6501-08-10	5/8	1/2-14	7/8-14	1.47	1.62	1.12	1.00	0.94	0.53	0.48
6501-08-12	3/4	1/2-14	1 1/16-12	1.56	1.78	1.22	1.25	1.13	0.53	0.61
6501-12-08	1/2	3/4-14	3/4-16	1.59	1.54	1.11	0.88	1.13	0.72	0.39
6501-12-12	3/4	3/4-14	1 1/16-12	1.59	1.75	1.19	1.25	1.13	0.72	0.61
6501-12-14	7/8	3/4-14	1 3/16-12	1.59	1.74	1.16	1.38	1.13	0.72	0.72
6501-16-16	1	1 -11 1/2	1 5/16-12	1.97	2.00	1.41	1.50	1.38	0.94	0.84
6501-20-20	1 1/4	1 1/4-11 1/2	1 5/8-12	2.38	2.31	1.68	2.00	1.75	1.25	1.08
6501-24-24	1 1/2	1 1/2-11 1/2	1 7/8-14	2.64	2.59	1.86	2.25	2.00	1.50	1.31
6501-32-32-FG	2	2-11 1/2	2 1/2-12	2.44	3.94	3.00	2.88	2.50	1.94	1.78

6502 45 DEGREE SWIVEL ELBOW

SAE J514 070321

MS51522

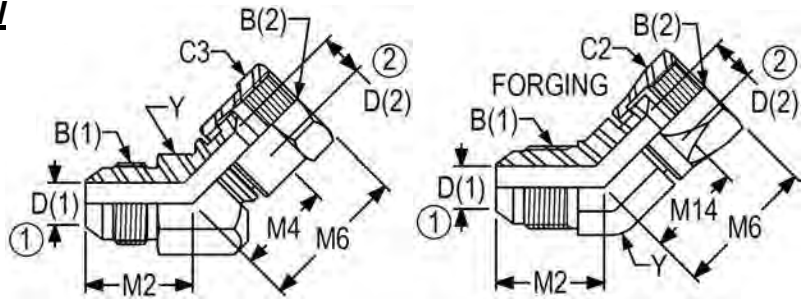

*Non forging parts are brazed construction

PART NO	TUBE OD	B (1) UN/UNF-2A	B (2) UN/UNF-2B	M2	M6	M14	C3	Y	D (1)	D (2)
6502-04-04	1/4-1/4	7/16-20	7/16-20	0.72	0.94	0.60	0.56	0.50	0.17	0.17
6502-04-04-FG	1/4-1/4	7/16-20	7/16-20	0.72	0.94	0.60	0.56	0.44	0.17	0.17
6502-05-05	5/16-5/16	1/2-20	1/2-20	0.77	1.00	0.63	0.63	0.56	0.23	0.23
6502-05-05-FG	5/16-5/16	1/2-20	1/2-20	0.77	1.00	0.63	0.63	0.56	0.23	0.23
6502-06-04	3/8-1/4	9/16-18	7/16-20	0.83	0.98	0.64	0.56	0.63	0.30	0.17
6502-06-06	3/8-3/8	9/16-18	9/16-18	0.83	1.12	0.75	0.69	0.63	0.30	0.30
6502-06-06-FG	3/8-3/8	9/16-18	9/16-18	0.83	1.12	0.75	0.69	0.56	0.30	0.30
6502-08-08	1/2-1/2	3/4-16	3/4-16	0.98	1.28	0.86	0.88	0.81	0.39	0.39
6502-08-08-FG	1/2-1/2	3/4-16	3/4-16	0.98	1.25	0.86	0.88	0.75	0.39	0.39
6502-10-08	5/8-1/2	7/8-14	3/4-16	1.11	1.23	0.81	0.88	0.94	0.48	0.39
6502-10-10	5/8-5/8	7/8-14	7/8-14	1.11	1.44	0.94	1.00	0.94	0.48	0.48
6502-10-10-FG	5/8-5/8	7/8-14	7/8-14	1.11	1.44	0.94	1.00	0.88	0.48	0.48
6502-12-12	3/4-3/4	1 1/16-12	1 1/16-12	1.28	1.50	0.94	1.25	1.13	0.61	0.61
6502-12-12-FG	3/4-3/4	1 1/16-12	1 1/16-12	1.28	1.50	0.94	1.25	1.06	0.61	0.61
6502-14-12	7/8-3/4	1 3/16-12	1 1/16-12	1.39	1.59	1.03	1.25	1.25	0.72	0.61
6502-14-14	7/8-7/8	1 3/16-12	1 3/16-12	1.39	1.59	1.01	1.38	1.25	0.72	0.72
6502-16-16	1-1	1 5/16-12	1 5/16-12	1.47	1.75	1.16	1.50	1.38	0.84	0.84
6502-16-16-FG	1-1	1 5/16-12	1 5/16-12	1.47	1.75	1.16	1.50	1.31	0.84	0.84
6502-16-20	1-1 1/4	1 5/8-12	1 5/8-12	1.54	2.03	1.40	2.00	1.75	0.84	1.08
6502-20-20	1 1/4-1 1/4	1 5/8-12	1 5/8-12	1.59	1.96	1.34	2.00	1.75	1.08	1.08
6502-20-20-FG	1 1/4-1 1/4	1 5/8-12	1 5/8-12	1.59	2.03	1.40	2.00	1.63	1.08	1.08
6502-20-32	1 1/4-2	1 5/8-12	2 1/2-12	1.84	2.71	1.77	2.88	2.63	1.08	1.78
6502-24-24	1 1/2-1 1/2	1 7/8-14	1 7/8-14	1.78	2.25	1.52	2.25	2.00	1.31	1.31
6502-24-24-FG	1 1/2-1 1/2	1 7/8-14	1 7/8-14	1.78	2.25	1.52	2.25	1.88	1.31	1.31
6502-32-32	2-2	2 1/2-12	2 1/2-12	2.22	2.91	1.97	2.88	2.63	1.78	1.78
6502-32-32-FG	2-2	2 1/2-12	2 1/2-12	2.22	2.91	1.97	2.88	2.50	1.78	1.78

6503 90 DEGREE FEMALE PIPE/SWIVEL ELBOW

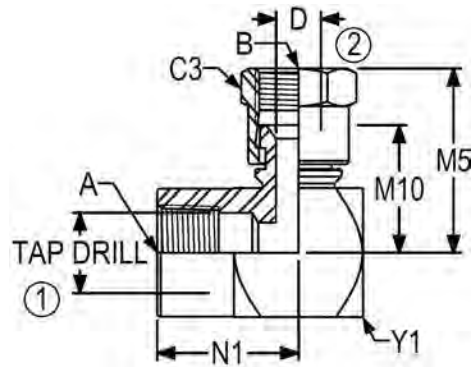

PART NO	TUBE OD	A NPTF	B UN/UNF-2B	N1	M5	M10	C3	Y1	TAP DRILL	D
6503-02-04	1/4	1/8-27	7/16-20	0.66	1.06	0.72	0.56	0.63	0.33	0.17
6503-04-04	1/4	1/4-18	7/16-20	0.88	1.13	0.78	0.56	0.75	0.43	0.17
6503-04-06	3/8	1/4-18	9/16-18	0.88	1.31	0.94	0.69	0.75	0.43	0.30
6503-06-06	3/8	3/8-18	9/16-18	1.02	1.38	1.00	0.69	0.88	0.57	0.30
6503-06-08	1/2	3/8-18	3/4-16	1.02	1.41	0.99	0.88	0.88	0.57	0.39
6503-08-06	3/8	1/2-14	9/16-18	1.23	1.50	1.13	0.69	1.13	0.70	0.30
6503-08-08	1/2	1/2-14	3/4-16	1.23	1.53	1.11	0.88	1.13	0.70	0.39
6503-08-10	5/8	1/2-14	7/8-14	1.23	1.71	1.21	1.00	1.13	0.70	0.48
6503-12-12	3/4	3/4-14	1 1/16-12	1.36	1.88	1.31	1.25	1.38	0.91	0.61
6503-16-16	1	1-11 1/2	1 5/16-12	1.62	2.15	1.56	1.50	1.63	1.14	0.84

6504 TUBE/SWIVEL UNION

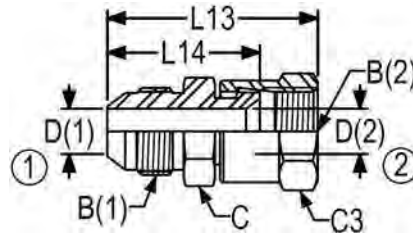

PART NO	TUBE OD	B (1) UN/UNF-2A	B (2) UN/UNF-2B	L13	L14	C	C3	D (1)	D (2)
6504-04-04	1/4-1/4	7/16-20	7/16-20	1.42	1.08	0.50	0.56	0.17	0.17
6504-05-05	5/16-5/16	1/2-20	1/2-20	1.48	1.10	0.56	0.63	0.23	0.23
6504-06-06	3/8-3/8	9/16-18	9/16-18	1.60	1.23	0.63	0.69	0.30	0.30
6504-08-08	1/2-1/2	3/4-16	3/4-16	1.73	1.31	0.81	0.88	0.39	0.39
6504-10-10	5/8-5/8	7/8-14	7/8-14	2.16	1.66	0.94	1.00	0.48	0.48
6504-12-10	3/4-5/8	1 1/16-12	7/8-14	2.24	1.74	1.13	1.00	0.61	0.48
6504-12-12	3/4-3/4	1 1/16-12	1 1/16-12	2.33	1.77	1.13	1.25	0.61	0.61
6504-12-14	3/4-7/8	1 1/16-12	1 3/16-12	2.31	1.74	1.38	1.38	0.61	0.72
6504-16-16	1-1	1 5/16-12	1 5/16-12	2.48	1.89	1.38	1.50	0.84	0.84
6504-20-20	1 1/4-1 1/4	1 5/8-12	1 5/8-12	2.69	2.07	1.69	2.00	1.08	1.08
6504-24-24	1 1/2-1 1/2	1 7/8-12	1 7/8-12	3.09	2.36	2.00	2.25	1.38	1.31
6504-32-32	2-2	2 1/2-12	2 1/2-12	3.46	2.70	2.75	2.88	1.78	1.78

6505 MALE PIPE/SWIVEL CONNECTOR

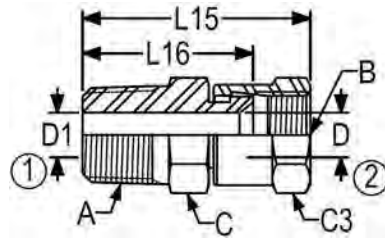

PART NO	TUBE OD	A NPTF	B UN/UNF-2B	L15	L16	C	C3	D1	D
6505-02-04	1/4	1/8-27	7/16-20	1.34	1.00	0.44	0.56	-----	0.17
6505-04-04	1/4	1/4-18	7/16-20	1.53	1.19	0.56	0.56	-----	0.17
6505-04-05	5/16	1/4-18	1/2-20	1.63	1.26	0.56	0.63	-----	0.23
6505-04-06	3/8	1/4-18	9/16-18	1.72	1.34	0.56	0.69	0.28	0.30
6505-06-06	3/8	3/8-18	9/16-18	1.72	1.34	0.75	0.69	-----	0.30
6505-06-08	1/2	3/8-18	3/4-16	1.73	1.31	0.81	0.88	-----	0.39
6505-06-10	5/8	3/8-18	7/8-14	1.91	1.41	0.88	1.00	0.41	0.48
6805-08-06	3/8	1/2-14	9/16-18	1.86	1.48	0.88	0.69	0.53	0.30
6505-08-08	1/2	1/2-14	3/4-16	1.90	1.48	0.88	0.88	-----	0.39
6505-08-10	5/8	1/2-14	7/8-14	2.28	1.78	0.94	1.00	-----	0.48
6505-08-12	3/4	1/2-14	1 1/16-12	2.26	1.70	1.13	1.25	0.53	0.61
6505-12-12	3/4	3/4-14	1 1/16-12	2.26	1.70	1.13	1.25	-----	0.61
6505-16-16	1	1-11 1/2	1 5/16-12	2.56	1.97	1.38	1.50	-----	0.84
6505-20-20	1 1/4	1 1/4-11 1/2	1 5/8-12	2.66	2.03	1.69	2.00	-----	1.08
6505-24-24	1 1/2	1 1/2-11 1/2	1 7/8-12	2.94	2.21	2.00	2.25	-----	1.31
6505-32-32	2	2-11 1/2	2 1/2-12	3.59	2.65	2.50	2.88	-----	1.78

6506 FEMALE PIPE/SWIVEL CONNECTOR

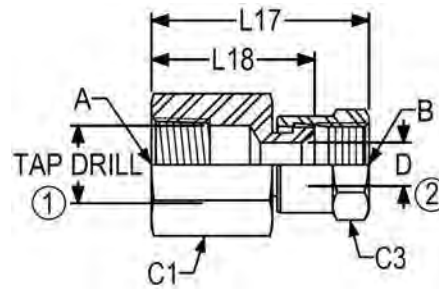

PART NO	TUBE OD	A NPTF	B UN/UNF-2B	L17	L18	C1	C3	TAP DRILL	D
6506-02-04	1/4	1/8-27	7/16-20	1.19	0.85	0.56	0.56	0.33	0.17
6506-04-04	1/4	1/4-18	7/16-20	1.44	1.09	0.75	0.56	0.43	0.17
6506-04-06	3/8	1/4-18	9/16-18	1.50	1.13	0.75	0.69	0.43	0.30
6506-04-08	1/2	1/4-18	3/4-16	1.60	1.18	0.88	0.88	0.43	0.39
6506-06-06	3/8	3/8-18	9/16-18	1.63	1.25	0.88	0.69	0.57	0.30
6506-06-08	1/2	3/8-18	3/4-16	1.61	1.19	0.88	0.88	0.57	0.39
6506-08-06	3/8	1/2-14	9/16-18	1.87	1.49	1.13	0.69	0.70	0.30
6506-08-08	1/2	1/2-14	3/4-16	1.91	1.49	1.13	0.88	0.70	0.39
6506-08-10	5/8	1/2-14	7/8-14	2.08	1.58	1.13	1.00	0.70	0.48
6506-08-12	3/4	1/2-14	1 1/16-12	2.08	1.51	1.13	1.25	0.70	0.61
6506-08-16	1	1/2-14	1 5/16-12	2.19	1.60	1.38	1.50	0.70	1.10
6506-12-10	5/8	3/4-14	7/8-14	2.11	1.62	1.38	1.00	0.91	0.48
6506-12-12	3/4	3/4-14	1 1/16-12	2.13	1.57	1.38	1.25	0.91	0.61
6506-12-14	7/8	3/4-14	1 3/16-12	2.09	1.51	1.38	1.38	0.91	0.72
6506-12-16	1	3/4-14	1 5/16-12	2.20	1.61	1.38	1.50	0.91	0.84
6506-16-16	1	1-11 1/2	1 5/16-12	2.63	2.03	1.63	1.50	1.14	0.84
6506-20-20	1 1/4	1 1/4-11 1/2	1 5/8-12	2.76	2.13	2.00	2.00	1.48	1.08
6506-24-24	1 1/2	1 1/2-11 1/2	1 7/8-12	2.98	2.25	2.38	2.25	1.72	1.31

6507 45 DEGREE FEMALE PIPE/SWIVEL ELBOW

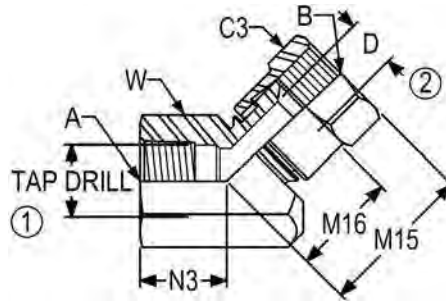

PART NO	TUBE OD	A NPTF	B UN/UNF-2B	N3	M15	M16	C3	W	TAP DRILL	D
6507-04-04	1/4	1/4-18	7/16-20	0.62	1.03	0.69	0.56	0.75	0.43	0.17
6507-04-06	3/8	1/4-18	9/16-18	0.62	1.21	0.83	0.69	0.75	0.43	0.30
6507-08-06	3/8	1/2-14	9/16-18	0.91	1.43	1.05	0.69	1.13	0.70	0.30
6507-08-10	5/8	1/2-14	7/8-14	0.91	1.48	0.98	1.00	1.13	0.70	0.48

6509 SWIVEL/ FEMALE STRAIGHT THREAD CONNECTOR

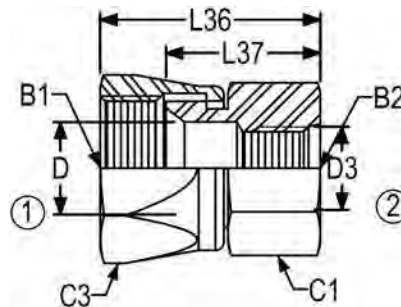

PART NO	B (1) UN/UNF-2B	B (2) UN/UNF-2B	L36	L37	C1	C3	D	D3
6509-16-08	3/4-16	1 5/16-12	2.00	1.40	1.38	1.50	0.84	0.813
6509-24-20	1 5/8-12	1 7/8-12	2.86	2.13	2.00	2.25	1.72	1.312

6565 DOUBLE SWIVEL UNION

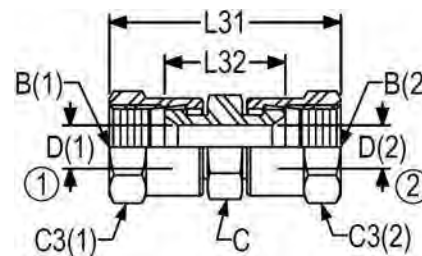

PART NO	TUBE OD	B(1) UN/UNF-2B	B(2) UN/UNF-2B	L31	L32	C	C3 (1)	C3 (2)	D (1)	D (2)
6565-04-04	1/4-1/4	7/16-20	7/16-20	1.51	0.83	0.43	0.56	0.56	0.17	0.17
6565-06-06	3/8-3/8	9/16-18	9/16-18	1.78	1.03	0.56	0.69	0.69	0.29	0.29
6565-08-08	1/2-1/2	3/4-16	3/4-16	1.92	1.08	0.81	0.88	0.88	0.39	0.39
6565-10-10	5/8-5/8	7/8-14	7/8-14	2.40	1.40	0.87	0.94	0.94	0.48	0.48
6565-12-12	3/4-3/4	1 1/16-12	1 1/16-12	2.54	1.42	1.12	1.25	1.25	0.60	0.60
6565-16-16	1-1	1 5/16-12	1 5/16-12	2.72	1.54	1.37	1.50	1.50	0.84	0.84
6565-20-20	1 1/4-1 1/4	1 5/8-12	1 5/8-12	2.89	1.64	1.68	2.00	2.00	1.07	1.07

6600 SWIVEL BRANCH TEE

SAE J514 070433
MS51524

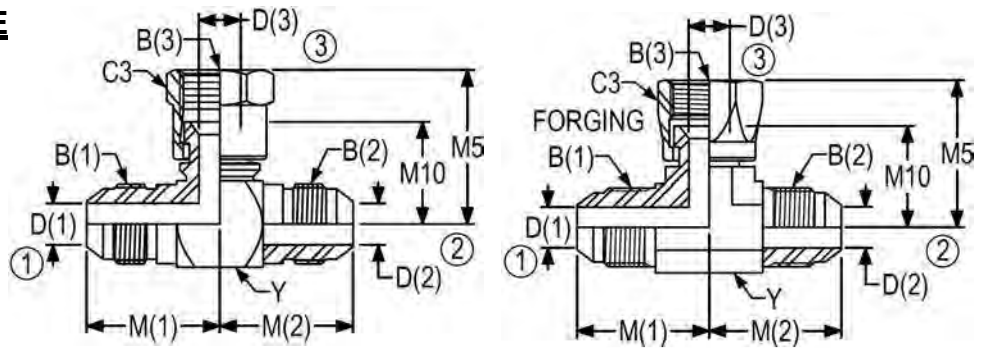

*Non forging parts are brazed construction

PART NO	TUBE OD	B (1) UN/UNF-2A	B (2) UN/UNF-2A	B (3) UN/UNF-2B	M (1)	M (2)	M5	M10
6600-04-04-04	1/4-1/4-1/4	7/16-20	7/16-20	7/16-20	0.89	0.89	1.00	0.66
6600-04-04-04-FG	1/4-1/4-1/4	7/16-20	7/16-20	7/16-20	0.89	0.89	1.00	0.66
6600-05-05-05	5/16-5/16-5/16	1/2-20	1/2-20	1/2-20	0.95	0.95	1.06	0.69
6600-05-05-05-FG	5/16-5/16-5/16	1/2-20	1/2-20	1/2-20	0.95	0.95	1.06	0.69
6600-06-06-06	3/8-3/8-3/8	9/16-18	9/16-18	9/16-18	1.06	1.06	1.25	0.88
6600-06-06-06-FG	3/8-3/8-3/8	9/16-18	9/16-18	9/16-18	1.06	1.06	1.25	0.88
6600-06-06-08	3/8-3/8-1/2	9/16-18	9/16-18	3/4-16	1.16	1.16	1.38	0.96
6600-08-08-08	1/2-1/2-1/2	3/4-16	3/4-16	3/4-16	1.25	1.25	1.38	0.96
6600-08-08-10	1/2-1/2-5/8	3/4-16	3/4-16	7/8-14	1.31	1.31	1.62	1.12
6600-08-08-12	1/2-1/2-3/4	3/4-16	3/4-16	1 1/16-12	1.40	1.40	1.75	1.19
6600-08-08-16	1/2-1/2-1	3/4-16	3/4-16	1 5/16-12	1.53	1.53	2.02	1.43
6600-10-08-10	5/8-1/2-5/8	7/8-14	3/4-16	7/8-14	1.45	1.31	1.62	1.12
6600-10-10-10	5/8-5/8-5/8	7/8-14	7/8-14	7/8-14	1.45	1.45	1.62	1.12
6600-10-10-10-FG	5/8-5/8-5/8	7/8-14	7/8-14	7/8-14	1.45	1.45	1.62	1.12
6600-12-12-10	3/4-3/4-5/8	1 1/16-12	1 1/16-12	7/8-14	1.66	1.66	1.71	1.21
6600-12-12-12	3/4-3/4-3/4	1 1/16-12	1 1/16-12	1 1/16-12	1.66	1.66	1.75	1.19
6600-12-12-12-FG	3/4-3/4-3/4	1 1/16-12	1 1/16-12	1 1/16-12	1.66	1.66	1.75	1.19
6600-12-12-16	3/4-3/4-1	1 1/16-12	1 1/16-12	1 5/16-12	1.78	1.78	2.02	1.43
6600-14-14-14	7/8-7/8-7/8	1 3/16-12	1 3/16-12	1 3/16-12	1.80	1.80	1.78	1.22
6600-16-12-12	1-3/4-3/4	1 5/16-12	1 1/16-12	1 1/16-12	1.81	1.78	1.88	1.31
6600-16-12-16	1-3/4-1	1 5/16-12	1 1/16-12	1 5/16-12	1.81	1.78	2.00	1.41
6600-16-16-08	1-1-1/2	1 5/16-12	1 5/16-12	3/4-16	1.81	1.81	1.66	1.24
6600-16-16-16	1-1-1	1 5/16-12	1 5/16-12	1 5/16-12	1.81	1.81	2.00	1.41
6600-16-16-16-FG	1-1-1	1 5/16-12	1 5/16-12	1 5/16-12	1.81	1.81	2.00	1.41
6600-20-12-16	1 1/4-3/4-1	1 5/8-12	1 1/16-12	1 5/16-12	2.06	1.97	2.21	1.62
6600-20-20-20	1 1/4-1 1/4-1 1/4	1 5/8-12	1 5/8-12	1 5/8-12	2.06	2.06	2.31	1.68
6600-20-20-20-FG	1 1/4-1 1/4-1 1/4	1 5/8-12	1 5/8-12	1 5/8-12	2.06	2.06	2.31	1.69
6600-24-24-24	1 1/2-1 1/2-1 1/2	1 7/8-12	1 7/8-12	1 7/8-12	2.33	2.33	2.59	1.86
6600-24-24-24-FG	1 1/2-1 1/2-1 1/2	1 7/8-12	1 7/8-12	1 7/8-12	2.33	2.33	2.59	1.86
6600-32-32-32	2-02-2	2 1/2-12	2 1/2-12	2 1/2-12	3.06	3.06	3.38	2.44
6600-32-32-32-FG	2-02-2	2 1/2-12	2 1/2-12	2 1/2-12	3.06	3.06	3.38	2.44

6600 SWIVEL BRANCH TEE

(Con't)

SAE J514 070433

MS51524

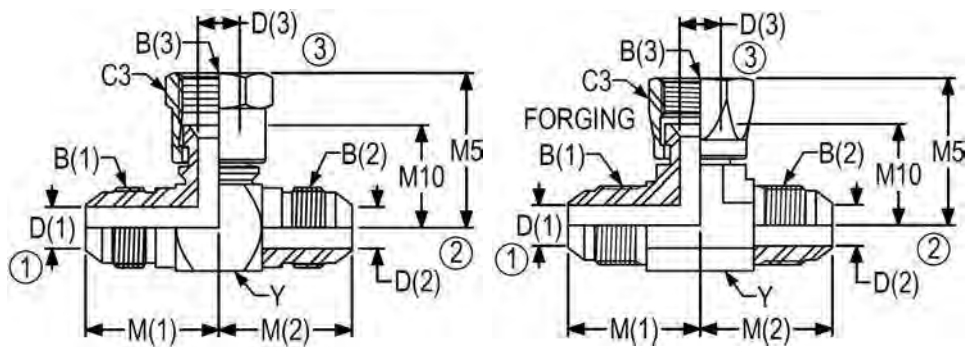

*Non forging parts are brazed construction

PART NO	C3	Y	D (1)	D (2)	D (3)
6600-04-04-04	0.56	0.50	0.17	0.17	0.17
6600-04-04-04-FG	0.56	0.44	0.17	0.17	0.17
6600-05-05-05	0.63	0.56	0.23	0.23	0.23
6600-05-05-05-FG	0.63	0.56	0.23	0.23	0.23
6600-06-06-06	0.69	0.63	0.30	0.30	0.30
6600-06-06-06-FG	0.69	0.56	0.30	0.30	0.30
6600-06-06-08	0.88	0.81	0.30	0.30	0.39
6600-08-08-08	0.88	0.81	0.39	0.39	0.39
6600-08-08-08-FG	0.88	0.75	0.39	0.39	0.39
6600-08-08-10	1.00	0.94	0.39	0.39	0.48
6600-08-08-12	1.25	1.13	0.39	0.39	0.61
6600-08-08-16	1.50	1.38	0.39	0.39	0.84
6600-10-08-10	1.00	0.94	0.48	0.39	0.48
6600-10-10-10	1.00	0.94	0.48	0.48	0.48
6600-10-10-10-FG	1.00	0.88	0.48	0.48	0.48
6600-12-12-10	1.00	1.13	0.61	0.61	0.48
6600-12-12-12	1.25	1.13	0.61	0.61	0.61
6600-12-12-12-FG	1.25	1.06	0.61	0.61	0.61
6600-12-12-16	1.50	1.38	0.61	0.61	0.84
6600-14-14-14	1.38	1.25	0.72	0.72	0.72
6600-16-12-12	1.25	1.38	0.84	0.61	0.61
6600-16-12-16	1.50	1.38	0.84	0.61	0.84
6600-16-16-08	0.88	1.38	0.84	0.84	0.39
6600-16-16-16	1.50	1.38	0.84	0.84	0.84
6600-16-16-16-FG	1.50	1.31	0.84	0.84	0.84
6600-20-12-16	1.50	1.75	1.08	0.61	0.84
6600-20-20-20	2.00	1.75	1.08	1.08	1.08
6600-20-20-20-FG	2.00	1.63	1.08	1.08	1.08
6600-24-24-24	2.25	2.00	1.31	1.31	1.31
6600-24-24-24-FG	2.25	1.88	1.31	1.31	1.31
6600-32-32-32	2.88	2.50	1.78	1.78	1.78
6600-32-32-32-FG	2.88	2.50	1.78	1.78	1.78

6602 SWIVEL RUN TEE

SAE J514 070432
MS51523

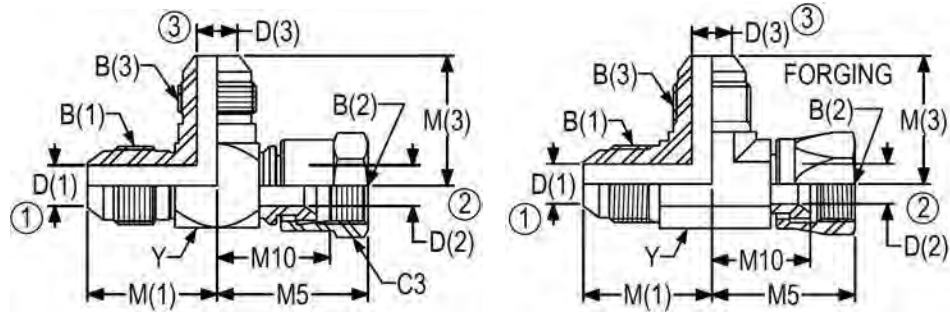

*Non forging parts are brazed construction

PART NO	TUBE OD	B (1) UN/UNF-2A	B (2) UN/UNF-2B	B (3) UN/UNF-2A	M (1)	M5	M10	M (3)
6602-04-04-04	1/4-1/4-1/4	7/16-20	7/16-20	7/16-20	0.89	1.00	0.66	0.89
6602-04-04-04-FG	1/4-1/4-1/4	7/16-20	7/16-20	7/16-20	0.89	1.00	0.66	0.89
6602-04-04-06	1/4-1/4-3/8	7/16-20	7/16-20	9/16-18	0.95	1.06	0.72	1.06
6602-04-06-04	1/4-3/8-1/4	7/16-20	9/16-18	7/16-20	0.95	1.25	0.88	0.95
6602-04-20-20	1/4-1 1/4-1 1/4	7/16-20	1 5/8-12	1 5/8-12	1.51	2.31	1.68	2.06
6602-05-05-05	5/16-5/16-5/16	1/2-20	1/2-20	1/2-20	0.95	1.06	0.69	0.95
6602-05-05-05-FG	5/16-5/16-5/16	1/2-20	1/2-20	1/2-20	0.95	1.06	0.69	0.95
6602-06-06-04	3/8-3/8-1/4	9/16-18	9/16-18	7/16-20	1.06	1.25	0.88	0.95
6602-06-06-06	3/8-3/8-3/8	9/16-18	9/16-18	9/16-18	1.06	1.25	0.88	1.06
6602-06-06-06-FG	3/8-3/8-3/8	9/16-18	9/16-18	9/16-18	1.06	1.25	0.88	1.06
6602-06-06-08-FG	3/8-3/8-1/2	9/16-18	9/16-18	3/4-16	1.22	1.33	0.95	1.22
6602-06-08-08	3/8-1/2-1/2	9/16-18	3/4-16	3/4-16	1.16	1.38	0.96	1.25
6602-08-08-04	1/2-1/2-1/4	3/4-16	3/4-16	7/16-20	1.25	1.38	0.96	1.05
6602-08-08-06	1/2-1/2-3/8	3/4-16	3/4-16	9/16-18	1.25	1.38	0.96	1.15
6602-08-08-06-FG	1/2-1/2-3/8	3/4-16	3/4-16	9/16-18	1.25	1.38	0.96	1.14

PART NO	C3	Y	D (1)	D (2)	D (3)
6602-04-04-04	0.56	0.50	0.17	0.17	0.17
6602-04-04-04-FG	0.56	0.44	0.17	0.17	0.17
6602-04-04-06	0.56	0.63	0.17	0.17	0.30
6602-04-06-04	0.69	0.63	0.17	0.30	0.17
6602-04-20-20	2.00	1.75	0.17	1.08	1.08
6602-05-05-05	0.63	0.56	0.23	0.23	0.23
6602-05-05-05-FG	0.63	0.56	0.23	0.23	0.23
6602-06-06-04	0.69	0.63	0.30	0.30	0.17
6602-06-06-06	0.69	0.63	0.30	0.30	0.30
6602-06-06-06-FG	0.69	0.56	0.30	0.30	0.30
6602-06-06-08-FG	0.69	0.75	0.32	0.30	0.39
6602-06-08-08	0.39	0.81	0.30	0.39	0.39
6602-08-08-04	0.88	0.81	0.39	0.39	0.17
6602-08-08-06	0.88	0.81	0.39	0.39	0.30
6602-08-08-06-FG	0.88	0.75	0.43	0.39	0.30

6602 SWIVEL RUN TEE

(Con't)

SAE J514 070432

MS51523

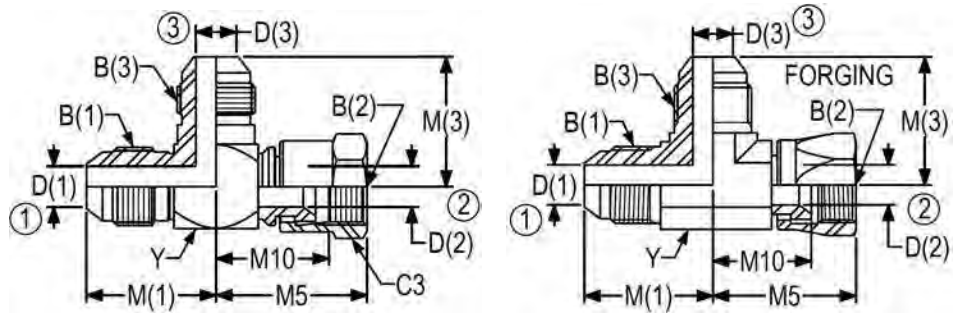

*Non forging parts are brazed construction

PART NO	TUBE OD	B (1) UN/UNF-2A	B (2) UN/UNF-2B	B (3) UN/UNF-2A	M (1)	M5	M10	M (3)
6602-08-08-08	1/2-1/2-1/2	3/4-16	3/4-16	3/4-16	1.25	1.38	0.96	1.25
6602-08-08-08-FG	1/2-1/2-1/2	3/4-16	3/4-16	3/4-16	1.25	1.38	0.96	1.25
6602-08-08-12	1/2-1/2-3/4	3/4-16	3/4-16	1 1/16-12	1.41	1.54	1.11	1.66
6602-08-12-08	1/2-3/4-1/2	3/4-16	1 1/16-12	3/4-16	1.40	1.75	1.19	1.40
6602-08-12-12	1/2-3/4-3/4	3/4-16	1 1/16-12	1 1/16-12	1.41	1.75	1.19	1.66
6602-10-08-08	5/8-1/2-1/2	7/8-14	3/4-16	3/4-16	1.45	1.44	1.02	1.31
6602-10-08-10	5/8-1/2-5/8	7/8-14	3/4-16	7/8-14	1.45	1.44	1.02	1.45
6602-10-08-10-FG	5/8-1/2-5/8	7/8-14	3/4-16	7/8-14	1.45	1.38	0.96	1.45
6602-10-10-04	5/8-5/8-1/4	7/8-14	7/8-14	7/16-20	1.45	1.62	1.12	1.11
6602-10-10-06	5/8-5/8-3/8	7/8-14	7/8-14	9/16-18	1.45	1.62	1.12	1.22
6602-10-10-06-FG	5/8-5/8-3/8	7/8-14	7/8-14	9/16-18	1.45	1.62	1.12	1.22
6602-10-10-08	5/8-5/8-1/2	7/8-14	7/8-14	3/4-16	1.45	1.62	1.12	1.31
6602-10-10-10	5/8-5/8-5/8	7/8-14	7/8-14	7/8-14	1.45	1.62	1.12	1.45
6602-10-10-10-FG	5/8-5/8-5/8	7/8-14	7/8-14	7/8-14	1.45	1.62	1.12	1.45
6602-10-10-12	5/8-5/8-3/4	7/8-14	7/8-14	1 1/16-12	1.55	1.71	1.21	1.66

PART NO	C3	Y	D (1)	D (2)	D (3)
6602-08-08-08	0.88	0.81	0.39	0.39	0.39
6602-08-08-08-FG	0.88	0.75	0.39	0.39	0.39
6602-08-08-12	0.88	1.13	0.39	0.39	0.61
6602-08-12-08	1.25	1.13	0.39	0.61	0.39
6602-08-12-12	1.25	1.13	0.39	0.61	0.61
6602-10-08-08	0.88	0.94	0.48	0.39	0.39
6602-10-08-10	0.88	0.94	0.48	0.39	0.48
6602-10-08-10-FG	0.88	0.88	0.48	0.39	0.48
6602-10-10-04	1.00	0.94	0.48	0.48	0.17
6602-10-10-06	1.00	0.94	0.48	0.48	0.30
6602-10-10-06-FG	1.00	0.88	0.48	0.48	0.30
6602-10-10-08	1.00	0.94	0.48	0.48	0.39
6602-10-10-10	1.00	0.94	0.48	0.48	0.48
6602-10-10-10-FG	1.00	0.88	0.48	0.48	0.48
6602-10-10-12	1.00	1.13	0.48	0.48	0.61

6602 SWIVEL RUN TEE

(Con't)

SAE J514 070432

MS51523

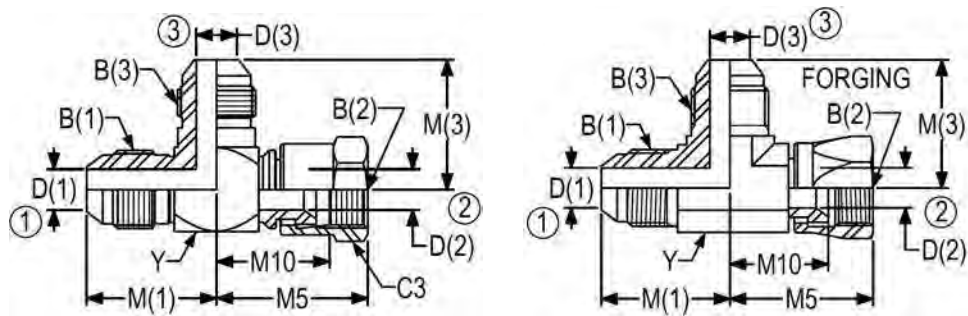

*Non forging parts are brazed construction

PART NO	TUBE OD	B (1) UN/UNF-2A	B (2) UN/UNF-2B	B (3) UN/UNF-2A	M (1)	M5	M10	M (3)
6602-10-12-10	5/8-3/4-5/8	7/8-14	1 1/16-12	7/8-14	1.55	1.75	1.19	1.55
6602-12-08-08	3/4-1/2-1/2	1 1/16-12	3/4-16	3/4-16	1.66	1.54	1.11	1.41
6602-12-12-04	3/4-3/4-1/4	1 1/16-12	1 1/16-12	7/16-20	1.66	1.75	1.19	1.20
6602-12-12-05	3/4-3/4-5/16	1 1/16-12	1 1/16-12	1/2-20	1.66	1.75	1.19	1.23
6602-12-12-08	3/4-3/4-1/2	1 1/16-12	1 1/16-12	3/4-16	1.66	1.75	1.19	1.41
6602-12-12-10	3/4-3/4-5/8	1 1/16-12	1 1/16-12	7/8-14	1.66	1.75	1.19	1.55
6602-12-12-12	3/4-3/4-3/4	1 1/16-12	1 1/16-12	1 1/16-12	1.66	1.75	1.19	1.66
6602-12-12-12-FG	3/4-3/4-3/4	1 1/16-12	1 1/16-12	1 1/16-12	1.66	1.75	1.19	1.66
6602-12-12-16	3/4-3/4-1	1 1/16-12	1 1/16-12	1 5/16-12	1.78	1.88	1.31	1.81
6602-12-16-12-FG	3/4-1-3/4	1 1/16-12	1 5/16-12	1 1/16-12	1.76	2.00	1.41	1.76
6602-12-16-12	3/4-1-3/4	1 1/16-12	1 5/16-12	1 1/16-12	1.78	2.00	1.41	1.78
6602-14-14-14	7/8-7/8-7/8	1 3/16-12	1 3/16-12	1 3/16-12	1.80	1.78	1.22	1.80
6602-16-10-06	1-5/8-3/8	1 5/16-18	7/8-14	9/16-18	1.81	1.83	1.33	1.44
6602-16-12-12	1-3/4-3/4	1 5/16-12	1 1/16-12	1 1/16-12	1.81	1.88	1.31	1.78
6602-16-16-04	1-1-1/4	1 5/16-12	1 5/16-12	7/16-20	1.81	2.00	1.41	1.33

PART NO	C3	Y	D (1)	D (2)	D (3)
6602-10-12-10	1.25	1.13	0.48	0.61	0.48
6602-12-08-08	0.88	1.13	0.61	0.39	0.39
6602-12-12-04	1.25	1.13	0.61	0.61	0.17
6602-12-12-05	1.25	1.13	0.61	0.61	0.23
6602-12-12-08	1.25	1.13	0.61	0.61	0.39
6602-12-12-10	1.25	1.13	0.61	0.61	0.48
6602-12-12-12	1.25	1.13	0.61	0.61	0.61
6602-12-12-12-FG	1.25	1.06	0.61	0.61	0.61
6602-12-12-16	1.25	1.38	0.61	0.61	0.84
6602-12-16-12	1.50	1.38	0.61	0.84	0.61
6602-12-16-12-FG	1.50	1.31	0.61	0.84	0.61
6602-14-14-14	1.38	1.25	0.72	0.72	0.72
6602-16-10-06	1.00	1.38	0.84	0.48	0.30
6602-16-12-12	1.25	1.38	0.84	0.61	0.61
6602-16-16-04	1.50	1.38	0.84	0.84	0.17

6602 SWIVEL RUN TEE

(Con't)

SAE J514 070432

MS51523

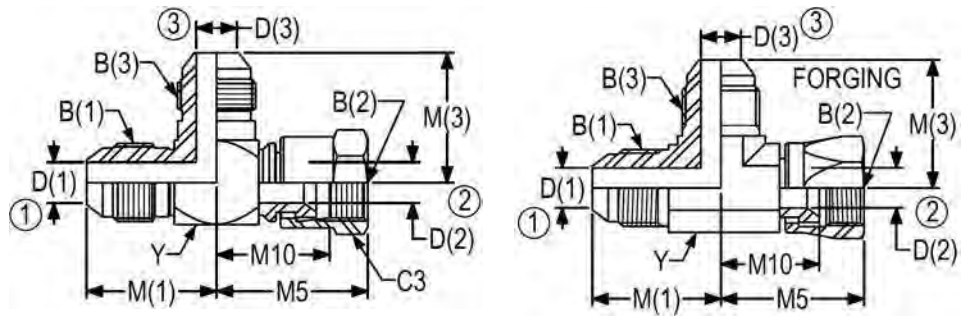

*Non forging parts are brazed construction

PART NO	TUBE OD	B (1) UN/UNF-2A	B (2) UN/UNF-2B	B (3) UN/UNF-2A	M (1)	M5	M10	M (3)
6602-16-16-08	1-1-1/2	1 5/16-12	1 5/16-12	3/4-16	1.81	1.86	1.44	1.53
6602-16-16-10	1-1-5/8	1 5/16-12	1 5/16-12	7/8-14	1.81	2.00	1.41	1.67
6602-16-16-10-FG	1-1-5/8	1 5/16-12	1 5/16-12	7/8-14	1.82	2.04	1.44	1.64
6602-16-16-12	1-1-3/4	1 5/16-12	1 5/16-12	1 1/16-12	1.81	2.00	1.41	1.78
6602-16-16-16	1-1-1	1 5/16-12	1 5/16-12	1 5/16-12	1.81	2.00	1.41	1.81
6602-16-16-16-FG	1-1-1	1 5/16-12	1 5/16-12	1 5/16-12	1.81	2.00	1.41	1.81
6602-20-20-12	1 1/4-1 1/4-3/4	1 5/8-12	1 5/8-12	1 1/16-12	2.06	2.31	1.68	1.97
6602-20-20-20	1 1/4-1 1/4-1 1/4	1 5/8-12	1 5/8-12	1 5/8-12	2.06	2.31	1.68	2.06
6602-24-24-24	1 1/2-1 1/2-1 1/2	1 7/8-12	1 7/8-12	1 7/8-12	2.33	2.59	1.86	2.33
6602-24-24-24-FG	1 1/2-1 1/2-1 1/2	1 7/8-12	1 7/8-12	1 7/8-12	2.30	2.59	1.86	2.33
6602-32-32-32	2-02-2	2 1/2-12	2 1/2-12	2 1/2-12	3.06	3.38	2.44	3.06
6602-32-32-32-FG	2-02-2	2 1/2-12	2 1/2-12	2 1/2-12	3.06	3.38	2.44	3.06

PART NO	C3	Y	D (1)	D (2)	D (3)
6602-16-16-08	0.88	1.38	0.84	0.84	0.39
6602-16-16-10	1.50	1.38	0.84	0.84	0.48
6602-16-16-10-FG	1.50	1.31	0.84	0.84	0.48
6602-16-16-12	1.50	1.38	0.84	0.84	0.61
6602-16-16-16	1.50	1.38	0.84	0.84	0.84
6602-16-16-16-FG	1.50	1.31	0.84	0.84	0.84
6602-20-20-12	2.00	1.75	1.08	1.08	0.61
6602-20-20-20	2.00	1.75	1.08	1.08	1.08
6602-24-24-24	2.25	2.00	1.31	1.31	1.31
6602-24-24-24-FG	2.25	1.85	1.31	1.31	1.31
6602-32-32-32	2.88	2.50	1.78	1.78	1.78
6602-32-32-32-FG	2.88	2.50	1.78	1.78	1.78

6603 SWIVEL RUN/RUN TEE

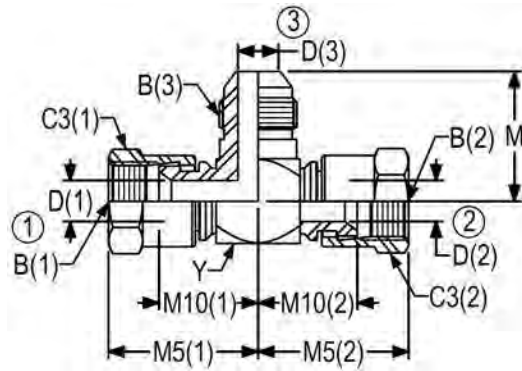

PART NO	TUBE OD	B (1) UN/UNF-2B	B (2) UN/UNF-2B	B (3) UN/UNF-2A	M5 (1)	M10 (1)	M5 (2)	M10 (2)
6603-04-04-04	1/4-1/4-1/4	7/16-20	7/16-20	7/16-20	1.00	0.66	1.00	0.66
6603-06-06-06	3/8-3/8-3/8	9/16-18	9/16-18	9/16-18	1.25	0.88	1.25	0.88
6603-08-08-08	1/2-1/2-1/2	3/4-16	3/4-16	3/4-16	1.38	0.96	1.38	0.96
6603-10-10-10	5/8-5/8-5/8	7/8-14	7/8-14	7/8-14	1.62	1.12	1.62	1.12
6603-12-12-12	3/4-3/4-3/4	1 1/16-12	1 1/16-12	1 1/16-12	1.75	1.19	1.75	1.19
6603-16-16-16	1-1-1	1 5/16-12	1 5/16-12	1 5/16-12	2.00	1.41	2.00	1.41
6603-20-20-20	1 1/4-1 1/4-1 1/4	1 5/8-12	1 5/8-12	1 5/8-12	2.31	1.69	2.31	1.69

PART NO	M	C3 (1)	C3 (2)	Y	D (1)	D (2)	D (3)
6603-04-04-04	0.89	0.56	0.56	0.50	0.17	0.17	0.17
6603-06-06-06	1.06	0.69	0.69	0.63	0.30	0.30	0.30
6603-08-08-08	1.25	0.88	0.88	0.81	0.39	0.39	0.39
6603-10-10-10	1.45	1.00	1.00	0.94	0.48	0.48	0.48
6603-12-12-12	1.66	1.25	1.25	1.13	0.61	0.61	0.61
6603-16-16-16	1.81	1.50	1.50	1.38	0.84	0.84	0.84
6603-20-20-20	2.06	2.00	2.00	1.75	1.08	1.08	1.08

6604 MALE PIPE/SWIVEL RUN/RUN TEE

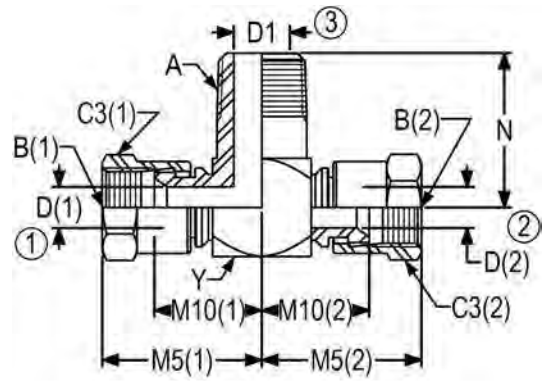

PART NO	TUBE OD	B (1) UN/UNF-2B	B (2) UN/UNF-2B	A NPTF	M5 (1)	M10 (1)	M5 (2)	M10 (2)
6604-04-04-04	1/4-1/4	7/16-20	7/16-20	1/4-18	1.06	0.72	1.06	0.72
6604-06-06-06	3/8-3/8	9/16-18	9/16-18	3/8-18	1.34	0.97	1.34	0.97
6604-08-08-08	1/2-1/2	3/4-16	3/4-16	1/2-14	1.44	1.02	1.44	1.02
6604-12-12-12	3/4-3/4	1 1/16-12	1 1/16-12	3/4-14	1.75	1.19	1.75	1.19
6604-16-16-16	1-1	1 5/16-12	1 5/16-12	1-11 1/2	2.04	1.44	2.04	1.44
6604-20-20-20	1 1/4-1 1/4	1 5/8-12	1 5/8-12	1 1/4-11 1/2	2.31	1.68	2.31	1.68

PART NO	N	C3 (1)	C3 (2)	Y	D (1)	D (2)	D1
6604-04-04-04	1.09	0.56	0.56	0.63	0.17	0.17	0.28
6604-06-06-06	1.22	0.69	0.69	0.81	0.30	0.30	0.41
6604-08-08-08	1.47	0.88	0.88	0.94	0.39	0.39	0.53
6604-12-12-12	1.59	1.25	1.25	1.13	0.61	0.61	0.72
6604-16-16-16	1.97	1.50	1.50	1.38	0.84	0.84	0.94
6604-20-20-20	2.38	2.00	2.00	1.75	1.08	1.08	1.25

6605 FEMALE PIPE/SWIVEL RUN/RUN TEE

INFORMATION AVAILABLE UPON REQUEST.
CALL CUSTOMER SERVICE FOR DETAILS.

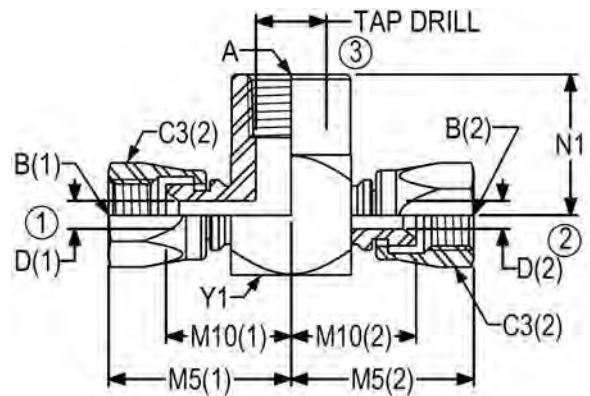

6606 SWIVEL TEE

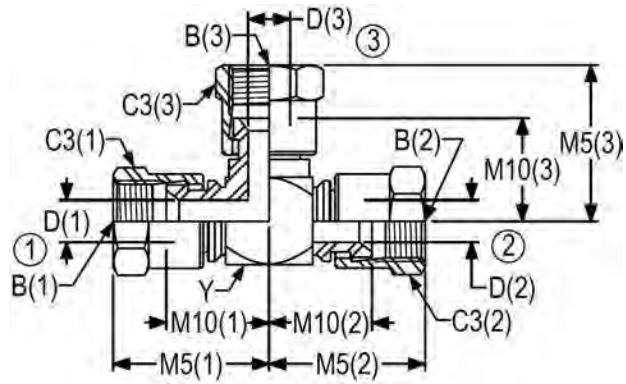

PART NO	TUBE OD	B (1) UN/UNF-2B	B (2) UN/UNF-2B	B (3) UN/UNF-2B	M5 (1)	M10 (1)	M5 (2)	M10 (2)	M5 (3)
6606-04-04-04	1/4-1/4-1/4	7/16-20	7/16-20	7/16-20	1.00	0.66	1.00	0.66	1.00
6606-06-06-06	3/8-3/8-3/8	9/16-18	9/16-18	9/16-18	1.25	0.88	1.25	0.88	1.25
6606-08-08-08	1/2-1/2-1/2	3/4-16	3/4-16	3/4-16	1.38	0.96	1.38	0.96	1.38
6606-12-12-12	3/4-3/4-3/4	1 1/16-12	1 1/16-12	1 1/16-12	1.75	1.19	1.75	1.19	1.75
6606-16-16-16	1-1-1	1 5/16-12	1 5/16-12	1 5/16-12	2.00	1.41	2.00	1.41	2.00

PART NO	M10 (3)	C3 (1)	C3 (2)	C3 (3)	Y	D (1)	D (2)	D (3)
6606-04-04-04	0.66	0.56	0.56	0.56	0.50	0.17	0.17	0.17
6606-06-06-06	0.88	0.69	0.69	0.69	0.63	0.30	0.30	0.30
6606-08-08-08	0.96	0.88	0.88	0.88	0.81	0.39	0.39	0.39
6606-12-12-12	1.19	1.25	1.25	1.25	1.13	0.61	0.61	0.61
6606-16-16-16	1.41	1.50	1.50	1.50	1.38	0.84	0.84	0.84

Features, Adjustable and O-Ring Fittings

O-Ring ports and stud ends per SAE J1926/ISO 11926 are the preferred port connection for use in hydraulic systems on industrial equipment and commercial products. The adjustable and O-Ring fittings described in this section provide a variety of options for connections between tube, hose or pipe ends to SAE J1926/1/ISO 11926-1 straight thread O-Ring ports or SAE J518 four-bolt flange ports. Fitting styles are available with male 37 degree tube ends, female 37 degree swivel ends, male or female NPTF pipe ends, female pipe swivels, adjustable and non-adjustable O-Ring studs, female O-Ring ports and low pressure beaded hose stem fittings.

The designs of the straight thread O-Ring stud per SAE J1926/3/ISO 11926-3 and the 37 degree flared fitting tube end per SAE J514/ISO 8434-2 are identical for either inch or metric tubing. With the exception of stock size, the flared tube fittings described in this section are interchangeable with the equivalent "inch" straight thread O-Ring stud fittings per ISO 8434-2. All 37 degree fitting styles are also available with the optional **FLARE-O®** tube end design.

Performance

Where applicable, fittings are designed and qualified to the requirements of SAE J514 and/or SAE J1926/3/ISO 11926-3. Beaded hose stem ends conform to SAE J1231 and are intended for suction or low pressure lines, typically less than 300 psi.

Construction

Unless otherwise specified, fittings are machined from cold drawn carbon steel barstock and forgings. Standard plating is electrodeposited zinc with a clear trivalent chromate conversion coating in accordance with ASTM B633 (Type V SC2). The minimum salt spray resistance is 240 hours to red corrosion when tested in accordance with ASTM B117

Threads

Straight Threads: Internal and external straight threads conform to the Unified National Class 2A and Class 2B Series respectively, with modified minor diameters where specified. Maximum diameters of plated external threads may conform to Class 3A maximum diameters after plating.

NPTF Threads: Male and female pipe threads conform to the Dryseal American Standard Taper Pipe Thread (SAE J476a, NPTF) Series which will provide pressure tight joints without the use of a lubricant or sealer. Use of these fittings with non-dryseal NPT pipe or hose ends is not recommended for high-pressure applications.

Note: Where not functionally objectionable, use of a compatible lubricant/sealant is recommended for either NPT or NPTF threads to minimize the possibility of galling in assembly.

Assembly Information

For assembly instructions, refer to the Technical Data Section for the appropriate fitting end. Also, refer to the Technical Data Section for recommendations regarding tubing pressure ratings, tube flares and hose/tube routing information. Please note the following:

Tubing for single flare tube ends should be either seamless or welded and drawn, fully annealed tubing per SAE J524 or J525. For double flaring, tubing per SAE J356, J524, J525 or J526 may be used.

For proper sealing with 37 degree flared fittings, flares for tubing should conform to the requirements of SAE J533. For heavy wall tubing, the optional tube preparation and single flare configuration specified in SAE J533 is also recommended. This optional configuration provides extended sealing surface contact area versus conventional flares.

In the design and fabrication of tubing or hose runs for any hydraulic system, precautions should be taken to allow for sufficient adjustment of the hose or tubing so that proper alignment can be attained at the fitting connections. Improper fit-up or misalignment should be corrected before final connections are made. Location of fitting connections should be planned to maximize accessibility. Whenever possible, use a torque wrench to tighten connections to the recommended torque.

Ordering Information

Size of fittings are indicated by dash number relating to sixteenths of an inch for the nominal O.D. of the tube size used. Example: 1/2 inch tube = 8/16 or (-8) size.

Order standard fittings from appropriate chart indicating required dash numbers. For example, 6405-08-06-O is 1/2" O-Ring stud end with 3/4-16 straight thread, and 3/8" female pipe thread. Jump size 6405-16-08-O is 1" O-Ring stud end with 1 5/16-12 straight thread and 1/2" female pipe thread. Pictorial views for each fitting style indicate the correct numbering sequence for fitting ends.

Adjustable and O-Ring fittings may be purchased in various stages of assembly. Catalog numbers include-NWO as standard. For example, 6801-10-10-NWO would be assembled with "N"- Nut, "W"- Washer and "O"- O-Ring. 6801-10-10NW would be assembled with "N"- Nut and "W"- Washer only.

If information is needed for jump sizes not shown, please contact customer service for engineering assistance.

Table JA1. Pressure Ratings for 37 Deg. Flared Tube Ends, 37 Deg. Female Swivels, O-Ring Port Plugs and Straight Thread Stud Ends (Inch)





Nominal Tube Size		Thread Size	Working Pressures							
Nom SAE Dash Size	Nom Inch Tube O.D.	SAE J514 Flared Tube End and SAE J1926/3/ISO 11926-3 O-Ring Port Thread Size (Notes 1&2)	37 Deg. Flared Tube Ends, Unions and Bulkheads		37 Deg. Female Swivels		SAE J514 (Inch) Port Plugs and Stud Ends Per SAE J1926/3/ISO 11926-3			
			MPa	psi	Mpa	psi	Port Plugs/Non-Adjustable Studs		Adjustable Studs	
			MPa	psi	Mpa	psi	MPa	psi	MPa	psi
-02	1/8	5/16-24 UNF	34.5	5,000	34.5	5,000	34.5	5,000	34.5	5,000
-03	3/16	3/8-24 UNF	34.5	5,000	34.5	5,000	34.5	5,000	34.5	5,000
-04	1/4	7/16-20 UNF	34.5	5,000	31	4,500	34.5	5,000	31.5	4,500
-05	5/16	1/2-20 UNF	34.5	5,000	27.5	4,000	34.5	5,000	27.5	4,000
-06	3/8	9/16-18 UNF	34.5	5,000	27.5	4,000	34.5	5,000	27.5	4,000
-08	1/2	3/4-16 UNF	31	4,500	27.5	4,000	31	4,500	27.5	4,000
-10	5/8	7/8-14 UNF	24	3,500	21	3,000	24	3,500	21	3,000
-12	3/4	1-1/16-12 UN	24	3,500	21	3,000	24	3,500	21	3,000
-14	7/8	1-3/16-12 UN	21	3,000	17	2,500	21	3,000	17	2,500
-16	1	1-5/16-12 UN	21	3,000	17	2,500	21	3,000	17	2,500
-20	1 1/4	1-5/8-12 UN	17	2,500	14	2,000	17	2,500	14	2,000
-24	1 1/2	1-7/8-12 UN	14	2,000	10.5	1,500	14	2,000	10.5	1,500
-32	2	2-1/2-12 UN	10.5	1,500	8	1,125	10.5	1,500	8	1,125

- 1) Threads per SAE J475 Class 2A ext. Class 2B int. (Ref. ISO-263/ISO-R725)
- 2) Unified class 2B threads apply to swivel nuts and with minor diameter modified to class 3B limits for locknuts

Table JA2. Pressure Ratings for Fittings With NPTF Pipe Threads and Adapter Unions

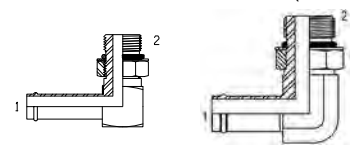
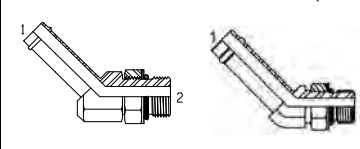
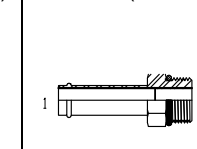
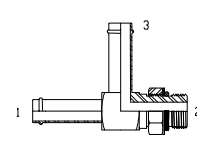
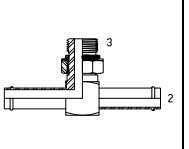
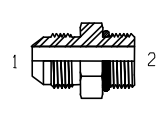
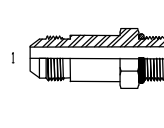
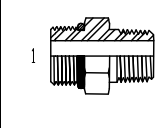
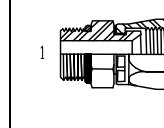
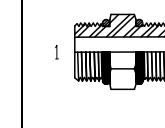
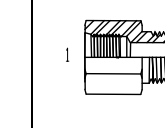
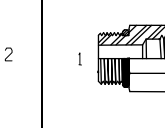
Nominal Pipe Size		Thread Size		Working Pressures			
Nom SAE Dash Size	Nom Inch Pipe O.D.	Dryseal Pipe Thread (NPTF ¹) Male and Female	Straight Pipe Thread (NPSM ²) Female Swivels	Fittings With NPTF Pipe Threads		Adapter Unions	
				MPa	psi	MPa	psi
-02	1/8	1/8-27	1/8-27	34.5	5,000	34.5	5,000
-04	1/4	1/4-18	1/4-18	27.5	4,000	34.5	5,000
-06	3/8	3/8-18	3/8-18	21	3,000	27.6	4,000
-08	1/2	1/2-14	1/2-14	21	3,000	24.1	3,500
-12	3/4	3/4-14	3/4-14	17	2,500	15.5	2,250
-16	1	1-11-1/2	1-11-1/2	14	2,000	13.8	2,000
-20	1 1/4	1-1/4-11-1/2	1-1/4-11-1/2	8	1,150	11.2	1,625
-24	1 1/2	1-1/2-11-1/2	1-1/2-11-1/2	7	1,000	8.6	1,250
-32	2	2-11-1/2	2-11-1/2	7	1,000	7.8	1,125

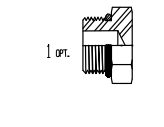
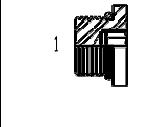
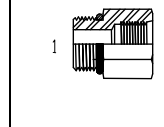
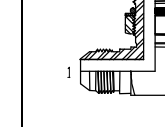
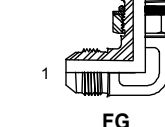
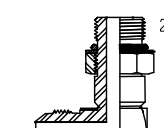
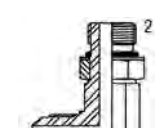
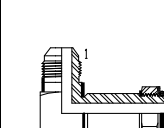
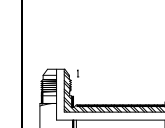
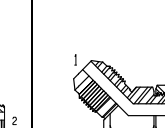
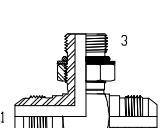
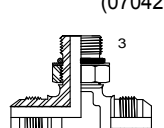
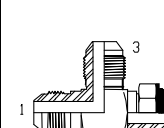
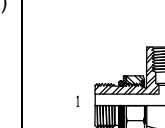
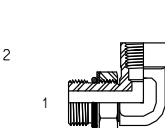
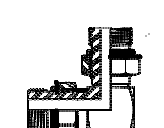
- 1) Dryseal American Standard Taper Pipe Thread
- 2) American Standard Straight Pipe Thread for Mechanical Joints

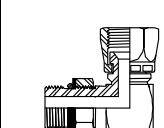
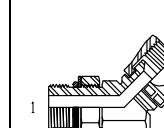
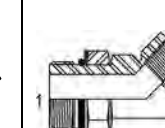
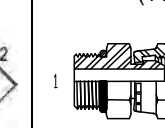
 <p>(430292)</p> <p>4601-NWO- (1)Beaded (2)Adjustable O-Ring</p>		 <p>(430392)</p> <p>4603-NWO- (1)Beaded (2)Adjustable O-Ring</p>		 <p>(430192)</p> <p>4604-O- (1)Beaded (2)Male O-Ring</p>		 <p>4605-NWO- (1&3)Beaded (2)Adjustable O-Ring</p>		 <p>4606-NWO- (1&2)Beaded (3)Adjustable O-Ring</p>					
 <p>(070120)</p> <p>6400-O- (1)Male Tube (2)Male O-Ring</p>		 <p>(070122)</p> <p>6400-L-O- (1)Male Tube (2)Male O-Ring-Long</p>		 <p>6401-O- (1)Male O-Ring (2)Male Pipe</p>		 <p>6402-O- (1)Male O-Ring (2)37° Female Swivel</p>		 <p>6403-O- (1&2)Male O-Ring</p>		 <p>6404- (1)Female O-Ring (2)Male Pipe</p>		 <p>6405-O- (1)Male O-Ring (2)Female Pipe</p>	
 <p>(090109A)</p> <p>6407-NWO- (1)Male O-Ring (2)Adjustable O-Ring</p>		 <p>(090109A)</p> <p>6408-O- (1)Male O-Ring</p>		 <p>(090109B)</p> <p>6409-O- (1)Male O-Ring</p>		 <p>(090109B)</p> <p>6410-O- (1)Male O-Ring (2)Female O-Ring</p>		 <p>(070220)</p> <p>6801-NWO- (1)Male Tube (2)Adjustable O-Ring</p>		 <p>6801-NWO- (1)Male Tube (2)Adjustable O-Ring</p>			
 <p>6801-L-NWO- (1)Male Tube (2)Adj. O-Ring-Long</p>		 <p>6801-LL-NWO- (1)Male Tube (2)Adj. O-Ring-XX-Long</p>		 <p>6801-LLL-NWO- (1)Male Tube (2)Adj. O-Ring-XX-Long</p>		 <p>(070320)</p> <p>6802-NWO- (1)Male Tube (2)Adjustable O-Ring</p>		 <p>6802-NWO- (1)Male Tube (2)Adjustable O-Ring</p>					
 <p>(070429)</p> <p>6803-NWO- (1&2)Male Tube (3)Adjustable O-Ring</p>		 <p>(070428)</p> <p>6804-NWO- (1&3)Male Tube (2)Adjustable O-Ring</p>		 <p>6805-NWO- (1)Adjustable O-Ring (2)Female Pipe</p>		 <p>6806-NWO- (1)Adjustable O-Ring (2)Male Pipe</p>							
 <p>6807-NWO- (1&2)Adjustable O-Ring</p>		 <p>6808-NWO- (1&2) Adjustable O-Ring</p>		 <p>6809-NWO- (1)Adjustable O-Ring (2)37° Female Swivel</p>		 <p>6810-NWO- (1)Adjustable O-Ring (2)37° Female Swivel</p>		 <p>6811-NWO- (1)Adjustable O-Ring (2)Female Pipe Elbow</p>		 <p>(140157)</p> <p>6900-O- (1)Male O-Ring (2)Female Pipe Swivel See adapter section</p>			

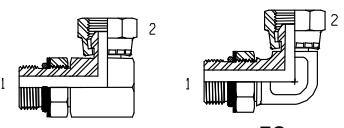
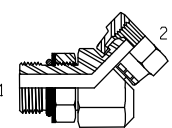
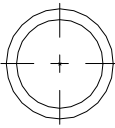
<p>(140257)</p>  <p>6901-NWO- (1)Adjustable O-Ring (2)Female Pipe Swivel See adapter section</p>	<p>(140357)</p>  <p>6902-NWO- (1)Adjustable O-Ring (2)Female Pipe Swivel See adapter section</p>				<p>(J515CH)</p>  <p>4000-O-Ring SAE J1926/2/3 Inch Stud Ends</p>
--	---	--	--	--	--

**4601 90 DEGREE STRAIGHT
THREAD HOSE FITTING**
SAE J1231 431492

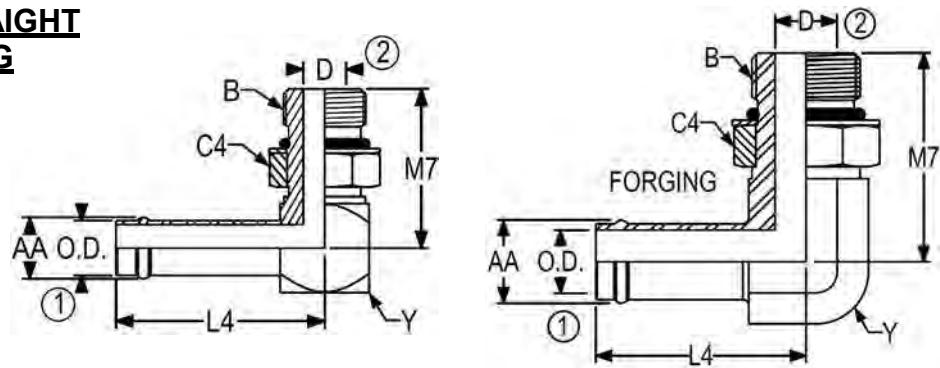

PART NO	TUBE OD	B UN/UNF-2A	L4	M7	C4	Y	AA	D
4601-04-02-NWO	1/4	5/16-24	1.75	0.94	0.44	0.50	0.29	0.06
4601-04-04-NWO	1/4	7/16-20	1.75	1.03	0.56	0.50	0.29	0.17
4601-04-05-NWO	1/4	1/2-20	1.78	1.13	0.63	0.56	0.29	0.23
4601-04-06-NWO	1/4	9/16-18	1.81	1.25	0.69	0.63	0.29	0.30
4601-05-04-NWO	5/16	7/16-20	1.75	1.03	0.56	0.50	0.36	0.17
4601-05-05-NWO	5/16	1/2-20	1.78	1.13	0.63	0.56	0.36	0.23
4601-05-06-NWO	5/16	9/16-18	1.81	1.25	0.69	0.63	0.36	0.30
4601-05-08-NWO	5/16	3/4-16	1.91	1.45	0.88	0.81	0.36	0.39
4601-06-04-NWO	3/8	7/16-20	1.75	1.03	0.56	0.50	0.43	0.17
4601-06-06-NWO	3/8	9/16-18	1.81	1.25	0.69	0.63	0.43	0.30
4601-06-08-NWO	3/8	3/4-16	1.91	1.45	0.88	0.81	0.43	0.39
4601-06-10-NWO	3/8	7/8-14	1.97	1.70	1.00	0.94	0.43	0.48
4601-06-12-NWO	3/8	1 1/16-12	2.06	1.94	1.25	1.13	0.43	0.61
4601-08-04-NWO	1/2	7/16-20	1.81	1.08	0.56	0.63	0.56	0.17
4601-08-06-NWO	1/2	9/16-18	1.81	1.25	0.69	0.63	0.56	0.30
4601-08-08-NWO	1/2	3/4-16	1.91	1.45	0.88	0.81	0.56	0.39
4601-08-10-NWO	1/2	7/8-14	1.97	1.70	1.00	0.94	0.56	0.48
4601-08-12-NWO	1/2	1 1/16-12	1.94	2.06	1.25	1.13	0.50	0.61
4601-08-16-NWO	1/2	1 5/16-12	2.19	2.05	1.50	1.38	0.56	0.84
4601-10-06-NWO	5/8	9/16-18	1.97	1.40	0.69	0.94	0.69	0.30
4601-10-08-NWO	5/8	3/4-16	1.91	1.45	0.88	0.81	0.69	0.39
4601-10-10-NWO	5/8	7/8-14	1.97	1.70	1.00	0.94	0.69	0.48
4601-10-12-NWO	5/8	1 1/16-12	2.06	1.94	1.25	1.13	0.69	0.61
4601-10-16-NWO	5/8	1 5/16-12	2.19	2.05	1.50	1.38	0.69	0.84
4601-12-08-NWO	3/4	3/4-16	1.91	1.45	0.88	0.81	0.82	0.39
4601-12-10-NWO	3/4	7/8-14	1.97	1.70	1.00	0.94	0.82	0.48
4601-12-12-NWO	3/4	1 1/16-12	2.06	1.94	1.25	1.13	0.82	0.61
4601-12-14-NWO	3/4	1 3/16-12	2.13	2.00	1.38	1.25	0.82	0.72
4601-12-20-NWO	3/4	1 5/8-12	2.38	2.25	1.88	1.75	0.82	1.08
4601-16-08-NWO	1	3/4-16	2.06	1.61	0.88	1.13	1.06	0.39
4601-16-10-NWO	1	7/8-14	2.06	1.80	1.00	1.13	1.06	0.48
4601-16-12-NWO	1	1 1/16-12	2.06	1.94	1.25	1.13	1.06	0.61
4601-16-14-NWO	1	1 3/16-12	2.12	2.00	1.38	1.25	1.06	0.72
4601-16-16-NWO	1	1 5/16-12	2.19	2.05	1.50	1.38	1.06	0.84
4601-16-20-NWO	1	1 5/8-12	2.38	2.25	1.88	1.75	1.06	1.08
4601-16-24-NWO	1	1 7/8-12	2.50	2.39	2.13	2.00	1.06	1.31

**4601 90 DEGREE STRAIGHT
THREAD HOSE FITTING (Con't)**

SAE J1231 431492

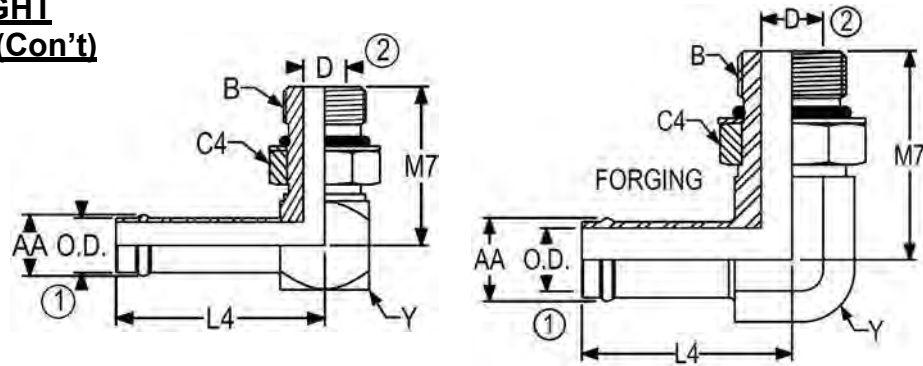

PART NO	TUBE OD	B UN/UNF-2A	L4	M7	C4	Y	AA	D
4601-18-12-NWO	1 1/8	1 1/16-12	2.19	2.06	1.25	1.38	1.23	0.61
4601-20-12-NWO	1 1/4	1 1/16-12	2.19	2.06	1.25	1.38	1.36	0.61
4601-20-16-NWO	1 1/4	1 5/16-12	2.19	2.05	1.50	1.38	1.36	0.84
4601-20-20-NWO	1 1/4	1 5/8-12	2.38	2.25	1.88	1.75	1.36	1.08
4601-20-20-NWO-FG	1 1/4	1 5/8-12	2.34	2.24	1.88	1.63	1.36	1.08
4601-20-24-NWO	1 1/4	1 7/8-12	2.50	2.39	2.13	2.00	1.36	1.31
4601-22-16-NWO	1 3/8	1 1/16-12	2.31	2.17	1.50	1.63	1.49	0.84
4601-24-12-NWO	1 1/2	1 1/16-12	2.31	2.19	1.25	1.63	1.62	0.61
4601-24-16-NWO	1 1/2	1 5/16-12	2.31	2.17	1.50	1.63	1.62	0.84
4601-24-20-NWO	1 1/2	1 5/8-12	2.38	2.25	1.88	1.75	1.62	1.08
4601-24-24-NWO	1 1/2	1 7/8-12	2.50	2.39	2.13	2.00	1.62	1.31
4601-32-32-NWO	2	2 1/2-12	2.81	2.89	2.75	2.63	2.15	1.78
4601-32-32-NWO-FG	2	2 1/2-12	2.81	2.89	2.75	2.50	2.15	1.78

**4603 45 DEGREE STRAIGHT
THREAD HOSE FITTING**
SAE J1231 430392

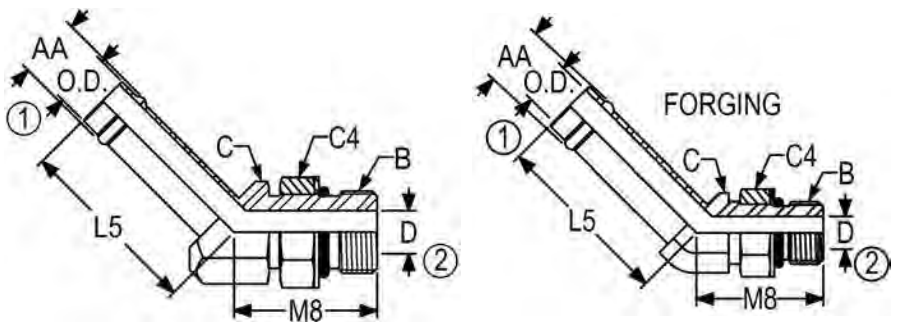

PART NO	TUBE OD	B UN/UNF-2A	L5	M8	C4	C	AA	D
4603-04-04-NWO	1/4	7/16-20	1.70	1.05	0.56	0.50	0.29	0.17
4603-04-04-NWO-FG	1/4	7/16-20	1.70	1.05	0.56	0.50	0.29	0.17
4603-04-06-NWO	1/4	9/16-18	1.70	1.14	0.69	0.63	0.29	0.30
4603-06-04-NWO	3/8	7/16-20	1.61	1.05	0.56	0.50	0.43	0.17
4603-06-06-NWO	3/8	9/16-18	1.69	1.14	0.69	0.63	0.43	0.30
4603-06-06-NWO-FG	3/8	9/16-18	1.69	1.14	0.69	0.63	0.43	0.30
4603-06-10-NWO	3/8	7/8-14	1.75	1.52	1.00	0.94	0.38	0.48
4603-08-06-NWO	1/2	9/16-18	1.61	1.14	0.69	0.63	0.56	0.30
4603-08-06-NWO-FG	1/2	9/16-18	1.61	1.14	0.69	0.63	0.56	0.30
4603-08-08-NWO	1/2	3/4-16	1.69	1.30	0.88	0.81	0.56	0.39
4603-08-10-NWO	1/2	7/8-14	1.76	1.52	1.00	0.94	0.56	0.48
4603-10-08-NWO	5/8	3/4-16	1.65	1.30	0.88	0.81	0.69	0.39
4603-10-10-NWO	5/8	7/8-14	1.70	1.52	1.00	0.94	0.69	0.48
4603-10-12-NWO	5/8	1 1/16-12	1.84	1.73	1.25	1.13	0.69	0.61
4603-10-16-NWO	5/8	1 5/16-12	1.96	1.86	1.50	1.38	0.69	0.84
4603-12-08-NWO	3/4	3/4-16	1.62	1.30	0.88	0.81	0.82	0.39
4603-12-10-NWO	3/4	7/8-14	1.66	1.52	1.00	0.94	0.82	0.48
4603-12-10-NWO-FG	3/4	7/8-14	1.66	1.52	1.00	0.94	0.82	0.48
4603-12-12-NWO	3/4	1 1/16-12	1.75	1.73	1.25	1.13	0.82	0.61
4603-12-16-NWO	3/4	1 5/16-12	1.90	1.86	1.50	1.38	0.82	0.84
4603-16-08-NWO	1	3/4-16	1.69	1.63	0.88	1.13	1.00	0.39
4603-16-10-NWO	1	7/8-14	1.64	1.59	1.00	1.13	1.06	0.48
4603-16-12-NWO	1	1 1/16-12	1.70	1.73	1.25	1.13	1.06	0.61
4603-16-14-NWO	1	1 3/16-12	1.78	1.80	1.38	1.25	1.06	0.72
4603-16-16-NWO	1	1 5/16-12	1.86	1.86	1.50	1.38	1.06	0.84
4603-16-20-NWO	1	1 5/8-12	1.92	1.91	1.88	1.75	1.06	1.08
4603-20-12-NWO	1 1/4	1 1/16-12	1.80	1.86	1.25	1.38	1.36	0.61
4603-20-14-NWO	1 1/4	1 3/16-12	1.85	1.86	1.38	1.38	1.36	0.72
4603-20-16-NWO	1 1/4	1 5/16-12	1.76	1.86	1.50	1.38	1.36	0.84
4603-20-20-NWO	1 1/4	1 5/8-12	1.92	1.91	1.88	1.75	1.36	1.08
4603-20-24-NWO	1 1/4	1 7/8-12	1.97	1.91	2.13	2.00	1.36	1.31
4603-24-16-NWO	1 1/2	1 5/16-12	1.80	1.91	1.50	1.75	1.62	0.84
4603-24-20-NWO	1 1/2	1 5/8-12	1.92	1.91	1.88	1.75	1.62	1.08
4603-24-24-NWO	1 1/2	1 7/8-12	1.97	1.91	2.13	2.00	1.62	1.31
4603-32-24-NWO	2	1 7/8-12	2.16	1.86	2.13	2.63	2.00	1.31
4603-32-32-NWO	2	2 1/2-12	2.14	1.86	2.75	2.63	2.15	1.78

4604 MALE STRAIGHT THREAD HOSE CONNECTOR

SAE J1231 430192

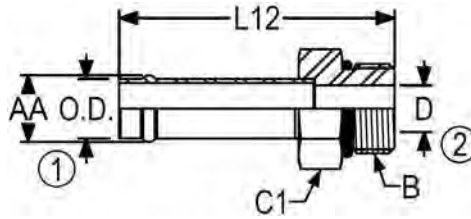

PART NO	TUBE OD	B UN/UNF-2A	L12	C1	AA	D
4604-04-03-O	1/4	3/8-24	2.07	0.50	0.29	0.13
4604-04-04-O	1/4	7/16-20	2.17	0.56	0.29	0.20
4604-04-06-O	1/4	9/16-18	2.23	0.69	0.29	0.21
4604-06-04-O	3/8	7/16-20	2.17	0.56	0.43	0.20
4604-06-06-O	3/8	9/16-18	2.23	0.69	0.43	0.30
4604-06-08-O	3/8	3/4-16	2.30	0.88	0.43	0.33
4604-08-06-O	1/2	9/16-18	2.23	0.69	0.56	0.30
4604-08-08-O	1/2	3/4-16	2.30	0.88	0.56	0.39
4604-08-10-O	1/2	7/8-14	2.43	1.00	0.56	0.43
4604-10-08-O	5/8	3/4-16	2.30	0.88	0.69	0.39
4604-10-10-O	5/8	7/8-14	2.43	1.00	0.69	0.50
4604-10-12-O	5/8	1 1/16-12	2.59	1.25	0.69	0.56
4604-10-16-O	5/8	1 5/16-12	2.63	1.50	0.69	0.56
4604-12-08-O	3/4	3/4-16	2.30	0.88	0.82	0.39
4604-12-10-O	3/4	7/8-14	2.43	1.00	0.82	0.50
4604-12-12-O	3/4	1 1/16-12	2.59	1.25	0.82	0.64
4604-12-16-O	3/4	1 5/16-12	2.62	1.50	0.82	0.64
4604-16-08-O	1	3/4-16	2.56	1.25	1.06	0.39
4604-16-10-O	1	7/8-14	2.62	1.25	1.06	0.50
4604-16-12-O	1	1 1/16-12	2.59	1.25	1.06	0.64
4604-16-16-O	1	1 5/16-12	2.62	1.50	1.06	0.89
4604-16-20-O	1	1 5/8-12	2.70	1.88	1.06	0.89
4604-16-24-O	1	1 7/8-12	2.77	2.13	1.06	0.89
4604-20-12-O	1 1/4	1 1/16-12	2.59	1.38	1.36	0.66
4604-20-14-O	1 1/4	1 3/16-12	2.59	1.38	1.36	0.72
4604-20-16-O	1 1/4	1 5/16-12	2.62	1.50	1.36	0.89
4604-20-20-O	1 1/4	1 5/8-12	2.70	1.88	1.36	1.09
4604-20-24-O	1 1/4	1 7/8-12	2.77	2.13	1.36	1.14
4604-22-12-O	1 3/8	1 1/16-12	2.62	1.63	1.49	0.61
4604-24-16-O	1 1/2	1 5/16-12	2.62	1.69	1.62	0.88
4604-24-20-O	1 1/2	1 5/8-12	2.70	1.88	1.62	1.09
4604-24-24-O	1 1/2	1 7/8-12	2.77	2.13	1.62	1.34
4604-32-20-O	2	1 5/8-12	2.86	2.25	2.15	1.09
4604-32-24-O	2	1 7/8-12	2.77	2.25	2.15	1.31
4604-32-32-O	2	2 1/2-12	2.93	2.75	2.15	1.78

4605 MALE STRAIGHT THREAD RUN HOSE CONNECTOR

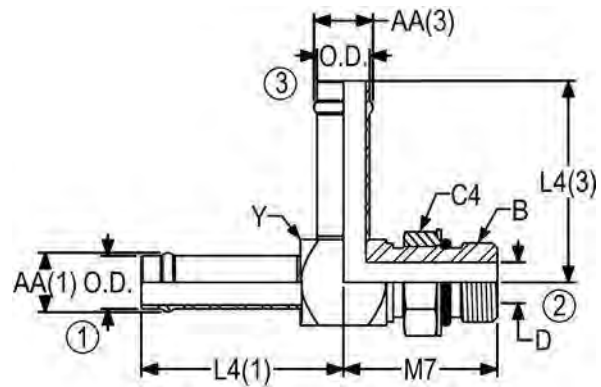

PART NO	TUBE OD	B UN/UNF-2A	L4 (1)	M7	L4 (3)	C4	Y	AA (1)	D	AA (3)
4605-05-06-06-NWO	5/16-3/8	9/16-18	1.81	1.25	1.81	0.69	0.63	0.36	0.30	0.43
4605-08-08-08-NWO	1/2-1/2	3/4-16	1.91	1.45	1.91	0.88	0.81	0.50	0.39	0.50
4605-10-10-10-NWO	5/8-5/8	7/8-14	1.97	1.70	1.97	1.00	0.94	0.69	0.48	0.69
4605-12-10-12-NWO	3/4-3/4	7/8-14	1.97	1.70	1.97	1.00	0.94	0.82	0.48	0.82
4605-12-12-12-NWO	3/4-3/4	1 1/16-12	2.06	1.94	2.06	1.25	1.13	0.82	0.61	0.82
4605-12-16-10-NWO	3/4-5/8	1 5/16-12	2.19	2.05	2.19	1.5	1.38	0.82	0.84	0.69
4605-16-12-16-NWO	1-1	1 1/16-12	2.20	2.05	2.19	1.25	1.38	1.06	0.61	1.06
4605-16-16-10-NWO	1-5/8	1 5/16-12	2.19	2.05	2.19	1.50	1.38	1.06	0.84	0.69
4605-16-16-16-NWO	1-1	1 5/16-12	2.19	2.05	2.19	1.50	1.38	1.06	0.84	1.06
4605-16-20-16-NWO	1-1	1 5/8-12	2.38	2.25	2.38	1.88	1.75	1.06	1.08	1.06
4605-20-16-20-NWO	1 1/4-1	1 5/16-12	2.31	2.17	2.31	1.50	1.63	1.36	0.84	1.36
4605-20-20-12-NWO	1 1/4-1 1/4	1 5/8-12	2.38	2.25	2.38	1.88	1.75	1.36	1.08	0.82
4605-20-20-16-NWO	1 1/4-1 1/4	1 5/8-12	2.38	2.25	2.38	1.88	1.75	1.36	1.08	1.06
4605-20-20-20-NWO	1 1/4-1 1/4	1 5/8-12	2.38	2.25	2.38	1.88	1.75	1.36	1.08	1.36
4605-24-24-24-NWO	1 1/2-1 1/2	1 7/8-12	2.50	2.39	2.50	2.13	2.00	1.62	1.31	1.62

4606 MALE STRAIGHT THREAD BRANCH HOSE

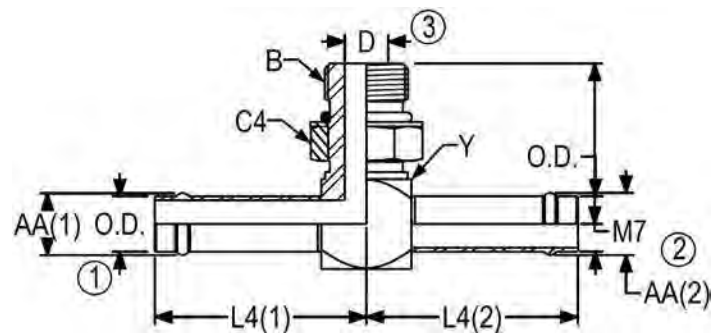

PART NO	TUBE OD	B UN/UNF-2A	L4 (1)	L4 (2)	M7	C4	Y	AA (1)	AA (2)	D
4606-04-04-04-NWO	1/2-1/2	7/16-20	1.75	1.75	1.03	0.56	0.50	0.25	0.25	0.17
4606-06-06-06-NWO	3/8-3/8	9/16-18	1.81	1.81	1.25	0.69	0.63	0.43	0.43	0.30
4606-08-08-06-NWO	1/2-1/2	9/16-18	1.81	1.81	1.25	0.69	0.63	0.50	0.50	0.30
4606-08-08-08-NWO	1/2-1/2	3/4-16	1.91	1.91	1.45	0.88	0.81	0.56	0.56	0.39
4606-10-10-10-NWO	5/8-5/8	7/8-14	1.97	1.97	1.70	1.00	0.94	0.69	0.69	0.48
4606-12-10-12-NWO	3/4-5/8	1 1/16-12	2.06	2.06	1.94	1.25	1.13	0.82	0.69	0.61
4606-12-12-12-NWO	3/4-3/4	1 1/16-12	2.06	2.06	1.94	1.25	1.13	0.82	0.82	0.61
4606-12-12-16-NWO	3/4-3/4	1 5/16-12	2.19	2.19	2.05	1.50	1.38	0.82	0.82	0.84
4606-16-12-12-NWO	1-3/4	1 1/16-12	2.06	2.06	1.94	1.25	1.13	1.00	0.75	0.61

6400 STRAIGHT THREAD CONNECTOR

SAE J514 070120
MS51525
MS39324

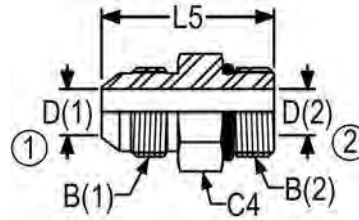

PART NO	TUBE OD	B (1) UN/UNF-2A	B (2) UN/UNF-2A	L5	C4	D (1)	D (2)
6400-02-02-O	1/8	5/16-24	5/16-24	1.06	0.44	0.06	0.06
6400-03-03-O	3/16	3/8-24	3/8-24	1.10	0.50	0.13	0.13
6400-03-04-O	3/16	3/8-24	7/16-20	1.16	0.56	0.13	0.17
6400-03-06-O	3/16	3/8-24	9/16-18	1.22	0.69	0.13	0.30
6400-04-02-O	1/4	7/16-20	5/16-24	1.17	0.50	0.17	0.06
6400-04-03-O	1/4	7/16-20	3/8-24	1.17	0.50	0.17	0.13
6400-04-04-O	1/4	7/16-20	7/16-20	1.23	0.56	0.17	0.17
6400-04-05-O	1/4	7/16-20	1/2-20	1.23	0.63	0.17	0.23
6400-04-06-O	1/4	7/16-20	9/16-18	1.29	0.69	0.17	0.30
6400-04-08-O	1/4	7/16-20	3/4-16	1.37	0.88	0.17	0.39
6400-04-10-O	1/4	7/16-20	7/8-14	1.49	1.00	0.17	0.48
6400-04-12-O	1/4	7/16-20	1 1/16-12	1.66	1.25	0.17	0.61
6400-05-04-O	5/16	1/2-20	7/16-20	1.23	0.56	0.23	0.17
6400-05-05-O	5/16	1/2-20	1/2-20	1.23	0.63	0.23	0.23
6400-05-06-O	5/16	1/2-20	9/16-18	1.29	0.69	0.23	0.30
6400-05-08-O	5/16	1/2-20	3/4-16	1.37	0.88	0.23	0.39
6400-05-10-O	5/16	1/2-20	7/8-14	1.49	1.00	0.23	0.48
6400-06-04-O	3/8	9/16-18	7/16-20	1.27	0.63	0.30	0.17
6400-06-05-O	3/8	9/16-18	1/2-20	1.27	0.63	0.30	0.23
6400-06-06-O	3/8	9/16-18	9/16-18	1.30	0.69	0.30	0.30
6400-06-08-O	3/8	9/16-18	3/4-16	1.38	0.88	0.30	0.39
6400-06-10-O	3/8	9/16-18	7/8-14	1.50	1.00	0.30	0.48
6400-06-12-O	3/8	9/16-18	1 1/16-12	1.66	1.25	0.30	0.61
6400-06-16-O	3/8	9/16-18	1 5/16-12	1.68	1.50	0.30	0.84
6400-08-04-O	1/2	3/4-16	7/16-20	1.49	0.81	0.39	0.17
6400-08-05-O	1/2	3/4-16	1/2-20	1.49	0.81	0.39	0.23
6400-08-06-O	1/2	3/4-16	9/16-18	1.44	0.81	0.39	0.30
6400-08-08-O	1/2	3/4-16	3/4-16	1.48	0.88	0.39	0.39
6400-08-10-O	1/2	3/4-16	7/8-14	1.60	1.00	0.39	0.48
6400-08-12-O	1/2	3/4-16	1 1/16-12	1.76	1.25	0.39	0.61
6400-08-14-O	1/2	3/4-16	1 3/16-12	1.76	1.38	0.39	0.72
6400-08-16-O	1/2	3/4-16	1 5/16-12	1.79	1.50	0.39	0.84
6400-10-06-O	5/8	7/8-14	9/16-18	1.71	0.94	0.48	0.30
6400-10-08-O	5/8	7/8-14	3/4-16	1.64	0.94	0.48	0.39
6400-10-10-O	5/8	7/8-14	7/8-14	1.70	1.00	0.48	0.48
6400-10-12-O	5/8	7/8-14	1 1/16-12	1.86	1.25	0.48	0.61

6400 STRAIGHT THREAD CONNECTOR

(Con't)

SAE J514 070120

MS51525

MS39324

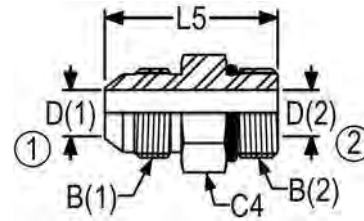

PART NO	TUBE OD	B (1) UN/UNF-2A	B (2) UN/UNF-2A	L5	C4	D (1)	D (2)
6400-10-14-O	5/8	7/8-14	1 3/16-12	1.86	1.38	0.48	0.72
6400-10-16-O	5/8	7/8-14	1 5/16-12	1.89	1.50	0.48	0.84
6400-10-20-O	5/8	7/8-14	1 5/8-12	1.97	1.88	0.48	1.08
6400-12-06-O	3/4	1 1/16-12	9/16-18	1.86	1.13	0.61	0.30
6400-12-08-O	3/4	1 1/16-12	3/4-16	1.94	1.13	0.61	0.39
6400-12-10-O	3/4	1 1/16-12	7/8-14	1.88	1.13	0.61	0.48
6400-12-12-O	3/4	1 1/16-12	1 1/16-12	1.97	1.25	0.61	0.61
6400-12-14-O	3/4	1 1/16-12	1 3/16-12	1.96	1.38	0.61	0.72
6400-12-16-O	3/4	1 1/16-12	1 5/16-12	1.99	1.50	0.61	0.84
6400-12-20-O	3/4	1 1/16-12	1 5/8-12	2.08	1.88	0.61	1.08
6400-12-24-O	3/4	1 1/16-12	1 7/8-12	2.15	2.13	0.61	1.31
6400-14-10-O	7/8	1 3/16-12	7/8-14	2.02	1.25	0.72	0.48
6400-14-12-O	7/8	1 3/16-12	1 1/16-12	1.99	1.25	0.72	0.61
6400-14-14-O	7/8	1 3/16-12	1 3/16-12	1.99	1.38	0.72	0.72
6400-14-16-O	7/8	1 3/16-12	1 5/16-12	2.02	1.50	0.72	0.84
6400-16-08-O	1	1 5/16-12	3/4-16	2.01	1.38	0.84	0.39
6400-16-10-O	1	1 5/16-12	7/8-14	2.07	1.38	0.84	0.48
6400-16-12-O	1	1 5/16-12	1 1/16-12	2.04	1.38	0.84	0.61
6400-16-14-O	1	1 5/16-12	1 3/16-12	2.04	1.38	0.84	0.72
6400-16-16-O	1	1 5/16-12	1 5/16-12	2.04	1.50	0.84	0.84
6400-16-20-O	1	1 5/16-12	1 5/8-12	2.12	1.88	0.84	1.08
6400-16-24-O	1	1 5/16-12	1 7/8-12	2.20	2.13	0.84	1.31
6400-20-12-O	1 1/4	1 5/8-12	1 1/16-12	2.30	1.69	1.08	0.61
6400-20-14-O	1 1/4	1 5/8-12	1 3/16-12	2.30	1.69	1.08	0.72
6400-20-16-O	1 1/4	1 5/8-12	1 5/16-12	2.33	1.69	1.08	0.84
6400-20-20-O	1 1/4	1 5/8-12	1 5/8-12	2.17	1.88	1.08	1.08
6400-20-24-O	1 1/4	1 5/8-12	1 7/8-12	2.24	2.13	1.08	1.31
6400-24-16-O	1 1/2	1 7/8-12	1 5/16-12	2.53	2.00	1.31	0.84
6400-24-20-O	1 1/2	1 7/8-12	1 5/8-12	2.53	2.00	1.31	1.08
6400-24-24-O	1 1/2	1 7/8-12	1 7/8-12	2.37	2.13	1.31	1.31
6400-24-32-O	1 1/2	1 7/8-12	2 1/2-12	2.53	2.75	1.31	1.78
6400-32-24-O	2	2 1/2-12	1 7/8-12	2.94	2.63	1.78	1.31
6400-32-32-O	2	2 1/2-12	2 1/2-12	2.78	2.75	1.78	1.78

6400-L STRAIGHT THREAD CONNECTOR**LONG**

SAE J514 071720 formally 070122

MS51526

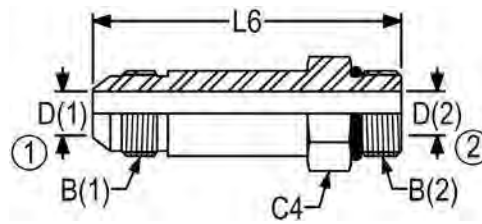

PART NO	TUBE OD	B (1) UN/UNF-2A	B (2) UN/UNF-2A	L6	C4	D (1)	D (2)
6400-L-04-04-O	1/4	7/16-20	7/16-20	2.08	0.56	0.17	0.17
6400-L-05-05-O	5/16	1/20-20	1/2-20	2.14	0.63	0.23	0.23
6400-L-06-06-O	3/8	9/16-18	9/16-18	2.31	0.69	0.30	0.30
6400-L-06-08-O	3/8	9/16-18	3/4-16	2.38	0.88	0.30	0.39
6400-L-06-10-O	3/8	9/16-18	7/8-14	2.51	1.00	0.30	0.48
6400-L-08-08-O	1/2	3/4-16	3/4-16	2.70	0.88	0.39	0.39
6400-L-08-10-O	1/2	3/4-16	7/8-14	2.83	1.00	0.39	0.48
6400-L-10-08-O	5/8	7/8-14	3/4-16	2.98	0.94	0.48	0.39
6400-L-10-10-O	5/8	7/8-14	7/8-14	3.04	1.00	0.48	0.48
6400-L-10-16-O	5/8	7/8-14	1 5/16-12	3.23	1.50	0.48	0.84
6400-L-12-10-O	3/4	1 1/16-12	7/8-14	3.52	1.13	0.61	0.48
6400-L-12-12-O	3/4	1 1/16-12	1 1/16-12	3.61	1.25	0.61	0.61
6400-L-12-16-O	3/4	1 1/16-12	1 5/16-12	3.64	1.50	0.61	0.84
6400-L-14-14-O	7/8	1 3/16-12	1 3/16-12	3.80	1.38	0.72	0.72
6400-L-16-16-O	1	1 5/16-12	1 5/16-12	3.98	1.50	0.84	0.84
6400-L-16-20-O	1	1 5/16-12	1 5/8-12	4.06	1.88	0.84	1.08
6400-L-20-16-O	1 1/4	1 5/8-12	1 5/16-12	4.85	1.69	1.08	0.84
6400-L-20-20-O	1 1/4	1 5/8-12	1 5/8-12	4.69	1.88	1.08	1.08
6400-L-24-24-O	1 1/2	1 7/8-12	1 7/8-12	5.17	2.13	1.31	1.31
6400-L-32-32-O	2	2 1/2-12	2 1/2-12	6.29	2.75	1.78	1.78

**6401 STRAIGHT THREAD/MALE PIPE
ADAPTER**

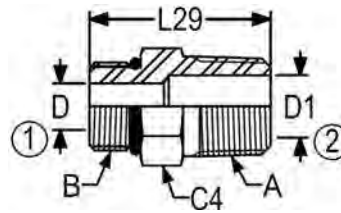

PART NO	B UN/UNF-2A	A NPTF	L29	C4	D	D1
6401-04-02-O	7/16-20	1/8-27	1.05	0.56	0.17	0.19
6401-04-04-O	7/16-20	1/4-18	1.23	0.56	0.17	0.28
6401-05-02-O	1/2-20	1/8-27	1.05	0.63	0.23	0.19
6401-05-04-O	1/2-20	1/4-18	1.16	0.63	0.23	0.28
6401-06-02-O	9/16-18	1/8-27	1.11	0.69	0.30	0.19
6401-06-04-O	9/16-18	1/4-18	1.30	0.69	0.30	0.28
6401-06-06-O	9/16-18	3/8-18	1.30	0.75	0.30	0.41
6401-06-08-O	9/16-18	1/2-14	1.48	0.88	0.30	0.53
6401-08-04-O	3/4-16	1/4-18	1.25	0.88	0.39	0.28
6401-08-06-O	3/4-16	3/8-18	1.36	0.88	0.39	0.41
6401-08-08-O	3/4-16	1/2-14	1.55	0.88	0.39	0.53
6401-08-12-O	3/4-16	3/4-14	1.58	1.13	0.39	0.72
6401-10-06-O	7/8-14	3/8-18	1.50	1.00	0.48	0.41
6401-10-08-O	7/8-14	1/2-14	1.69	1.00	0.48	0.53
6401-10-12-O	7/8-14	3/4-14	1.76	1.13	0.48	0.72
6401-12-06-O	1 1/16-12	3/8-18	1.66	1.25	0.61	0.41
6401-12-08-O	1 1/16-12	1/2-14	1.84	1.25	0.61	0.53
6401-12-12-O	1 1/16-12	3/4-14	1.73	1.25	0.61	0.72
6401-12-16-O	1 1/16-12	1-11 1/2	2.03	1.38	0.61	0.94
6401-16-12-O	1 5/16-12	3/4-14	1.87	1.50	0.84	0.72
6401-16-16-O	1 5/16-12	1-11 1/2	2.06	1.50	0.84	0.94
6401-20-20-O	1 5/8-12	1 1/4-11 1/2	2.17	1.88	1.08	1.25
6401-24-16-O	1 7/8-12	1-11 1/2	2.20	2.13	1.31	0.94
6401-24-20-O	1 7/8-12	1 1/4-11 1/2	2.23	2.13	1.31	1.25
6401-24-24-O	1 7/8-12	1 1/2-11 1/2	2.27	2.13	1.31	1.50
6401-32-32-O	2 1/2-12	2-11 1/2	2.47	2.75	1.78	1.94

6402 STRAIGHT THREAD/SWIVEL ADAPTER

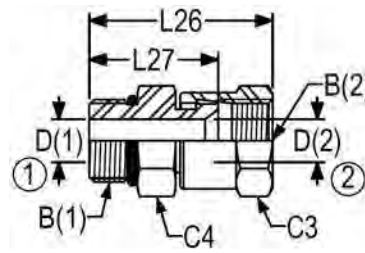

PART NO	TUBE OD	B (1) UN/UNF-2A	B (2) UN/UNF-2B	L26	L27	C4	C3	D (1)	D (2)
6402-04-04-O	1/4	7/16-20	7/16-20	1.29	0.95	0.56	0.56	0.17	0.17
6402-04-06-O	3/8	7/16-20	9/16-18	1.43	1.06	0.56	0.69	0.17	0.30
6402-06-04-O	1/4	9/16-18	7/16-20	1.34	1.00	0.69	0.56	0.30	0.17
6402-06-06-O	3/8	9/16-18	9/16-18	1.48	1.11	0.69	0.69	0.30	0.30
6402-06-08-O	1/2	9/16-18	3/4-16	1.48	1.06	0.75	0.88	0.30	0.39
6402-08-06-O	3/8	3/4-16	9/16-18	1.55	1.18	0.88	0.69	0.39	0.30
6402-08-08-O	1/2	3/4-16	3/4-16	1.59	1.17	0.88	0.88	0.39	0.39
6402-08-16-O	1	3/4-16	1 5/16-12	2.25	1.66	1.38	1.50	0.39	0.84
6402-10-08-O	1/2	7/8-14	3/4-16	1.72	1.30	1.00	0.88	0.48	0.39
6402-10-10-O	5/8	7/8-14	7/8-14	1.95	1.45	1.00	1.00	0.48	0.48
6402-12-08-O	1/2	1 1/16-12	3/4-16	1.71	1.29	1.25	0.88	0.61	0.39
6402-12-12-O	3/4	1 1/16-12	1 1/16-12	2.17	1.61	1.25	1.25	0.61	0.61
6402-12-16-O	1	1 1/16-12	1 5/16-12	2.28	1.69	1.38	1.50	0.61	0.84
6402-12-20-O	1 1/4	1 1/16-12	1 5/8-12	2.45	1.83	1.69	2.00	0.61	1.08
6402-16-12-O	3/4	1 5/16-12	1 1/16-12	2.19	1.63	1.50	1.25	0.84	0.61
6402-16-16-O	1	1 5/16-12	1 5/16-12	2.28	1.69	1.50	1.50	0.84	0.84
6402-16-20-O	1 1/4	1 5/16-12	1 5/8-12	2.51	1.88	2.00	2.00	0.84	1.08
6402-16-24-O	1 1/2	1 5/16-12	1 7/8-12	2.88	2.15	2.00	2.25	0.84	1.31
6402-20-20-O	1 1/4	1 5/8-12	1 5/8-12	2.45	1.83	1.88	2.00	1.08	1.08
6402-24-20-O	1 1/4	1 7/8-12	1 5/8-12	1.90	1.27	2.13	2.00	1.31	1.08
6402-24-24-O	1 1/2	1 7/8-12	1 7/8-12	2.72	1.99	2.13	2.25	1.31	1.31
6402-32-32-O	2	2 1/2-12	2 1/2-12	2.93	1.99	2.75	2.88	1.78	1.78

6403 STRAIGHT THREAD UNION

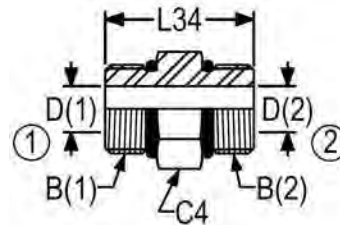

PART NO	TUBE OD	B (1) UN/UNF-2A	B (2) UN/UNF-2A	L34	C4	D (1)	D (2)
6403-06-04-O	3/8-1/4	9/16-18	7/16-20	1.11	0.69	0.30	0.17
6403-06-06-O	3/8-3/8	9/16-18	9/16-18	1.13	0.69	0.30	0.30
6403-08-08-O	1/2-1/2	3/4-16	3/4-16	1.26	0.88	0.39	0.39
6403-10-08-O	5/8-1/2	7/8-14	3/4-16	1.38	1.00	0.48	0.39
6403-10-10-O	5/8-5/8	7/8-14	7/8-14	1.44	1.00	0.48	0.48
6403-12-08-O	3/4-1/2	1 1/16-12	3/4-16	1.79	1.25	0.61	0.39
6403-12-12-O	3/4-3/4	1 1/16-12	1 1/16-12	1.68	1.25	0.61	0.61
6403-16-12-O	1-3/4	1 5/16-12	1 1/16-12	1.72	1.50	0.84	0.61

6404 O-RING PORT/MALE PIPE ADAPTER

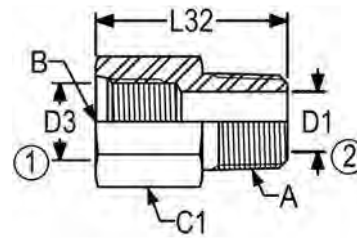

ART NO	B UN/UNF-2B	A NPTF	L32	C1	D3	D1
6404-04-02	7/16-20	1/8-27	1.13	0.69	0.38	0.19
6404-04-04	7/16-20	1/4-18	1.31	0.69	0.38	0.28
6404-04-06	7/16-20	3/8-18	1.14	0.69	0.38	0.38
6404-04-08	7/16-20	1/2-14	0.97	0.88	0.36	0.36
6404-05-02	1/2-20	1/8-27	1.19	0.75	0.45	0.19
6404-06-04	9/16-18	1/4-18	1.38	0.88	0.50	0.28
6404-06-06	9/16-18	3/8-18	1.38	0.88	0.50	0.41
6404-06-08	9/16-18	1/2-14	1.10	0.88	0.50	0.50
6404-08-04	3/4-16	1/4-18	1.73	1.00	0.68	0.28
6404-08-06	3/4-16	3/8-18	1.50	1.00	0.68	0.41
6404-08-08	3/4-16	1/2-14	1.69	1.00	0.68	0.53
6404-08-16	1 1/16-12	1-11 1/2	1.83	1.38	0.97	0.39
6404-08-24	3/4-16	1 1/2-11 1/2	1.93	2.00	0.68	0.68
6404-10-06	7/8-14	3/8-18	1.63	1.25	0.80	0.41
6404-10-08	7/8-14	1/2-14	1.81	1.25	0.80	0.53
6404-10-12	7/8-14	3/4-14	1.78	1.13	0.80	0.72
6404-12-06	1 1/16-12	3/8-18	1.78	1.38	0.97	0.41
6404-12-08	1 1/16-12	1/2-14	1.97	1.38	0.97	0.53
6404-12-12	1 1/16-12	3/4-14	1.97	1.38	0.97	0.72
6404-12-16	1 1/16-12	1-11 1/2	2.16	1.38	0.97	0.94
6404-16-12	1 5/16-12	3/4-14	1.97	1.63	1.22	0.72
6404-16-16	1 5/16-12	1-11 1/2	2.16	1.63	1.22	0.94
6404-16-20	1 5/16-12	1 1/4-11 1/2	1.91	1.75	1.22	1.22
6404-20-16	1 5/8-12	1-11 1/2	2.22	2.00	1.53	0.94
6404-20-20	1 5/8-12	1 1/4-11 1/2	2.25	2.00	1.53	1.25
6404-24-24	1 7/8-12	1 1/2-11 1/2	2.30	2.25	1.78	1.50

**6405 STRAIGHT THREAD/FEMALE PIPE
ADAPTER**

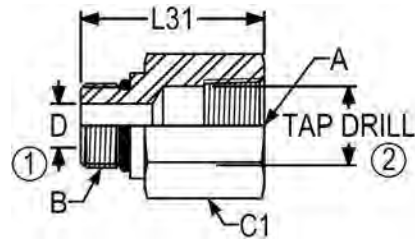

PART NO	B UN/UNF-2A	A NPTF	L31	C1	D	TAP DRILL
6405-03-04-O	3/8-24	1/4-18	1.10	0.75	0.13	0.43
6405-04-02-O	7/16-20	1/8-27	0.97	0.56	0.17	0.33
6405-04-04-O	7/16-20	1/4-18	1.16	0.75	0.17	0.43
6405-04-06-O	7/16-20	3/8-18	1.25	0.88	0.17	0.57
6405-05-02-O	1/2-20	1/8-27	0.94	0.63	0.23	0.33
6405-05-04-O	1/2-20	1/4-18	1.15	0.75	0.23	0.43
6405-06-02-O	9/16-18	1/8-27	0.73	0.69	0.33	0.33
6405-06-04-O	9/16-18	1/4-18	1.18	0.69	0.30	0.43
6405-06-06-O	9/16-18	3/8-18	1.31	0.88	0.30	0.57
6405-06-08-O	9/16-18	1/2-14	1.50	1.13	0.30	0.70
6405-08-02-O	3/4-16	1/8-27	0.80	0.88	0.33	0.33
6405-08-04-O	3/4-16	1/4-18	1.02	0.88	0.43	0.43
6405-08-06-O	3/4-16	3/8-18	1.26	0.88	0.39	0.57
6405-08-08-O	3/4-16	1/2-14	1.63	1.13	0.39	0.70
6405-08-12-O	3/4-16	3/4-14	1.63	1.38	0.39	0.91
6405-10-02-O	7/8-14	1/8-27	0.93	1.00	0.33	0.33
6405-10-04-O	7/8-14	1/4-18	0.93	1.00	0.43	0.43
6405-10-06-O	7/8-14	3/8-18	1.28	1.00	0.48	0.57
6405-10-08-O	7/8-14	1/2-14	1.55	1.13	0.48	0.70
6405-10-12-O	7/8-14	3/4-14	1.64	1.38	0.48	0.91
6405-12-04-O	1 1/16-12	1/4-18	1.09	1.25	0.43	0.43
6405-12-06-O	1 1/16-12	3/8-18	1.09	1.25	0.57	0.57
6405-12-08-O	1 1/16-12	1/2-14	1.50	1.25	0.61	0.70
6405-12-12-O	1 1/16-12	3/4-14	1.59	1.38	0.61	0.91
6405-12-16-O	1 1/16-12	1-11 1/2	1.95	1.63	0.61	1.14
6405-12-24-O	1 1/16-12	1 1/2-11 1/2	2.27	2.38	0.61	1.72
6405-14-08-O	1 3/16-12	1/2-14	1.47	1.38	0.70	0.70
6405-14-12-O	1 3/16-12	3/4-14	1.60	1.38	0.72	0.91
6405-16-02-O	1 5/16-12	1/8-2	1.12	1.50	0.33	0.33
6405-16-04-O	1 5/16-12	1/4-18	1.12	1.50	0.43	0.43
6405-16-06-O	1 5/16-12	3/8-18	1.00	1.50	0.57	0.57
6405-16-08-O	1 5/16-12	1/2-14	1.47	1.50	0.70	0.70
6405-16-12-O	1 5/16-12	3/4-14	1.62	1.50	0.84	0.91
6405-16-16-O	1 5/16-12	1-11 1/2	1.90	1.63	0.84	1.14
6405-16-20-O	1 5/16-12	1 1/4-11 1/2	2.09	2.00	0.84	1.48
6405-16-24-O	1 5/16-12	1 1/2-11 1/2	2.28	2.38	0.84	1.72
6405-20-04-O	1 5/8-12	1/4-18	1.20	1.88	0.43	0.43
6405-20-06-O	1 5/8-12	3/8-18	1.20	1.88	0.57	0.57
6405-20-08-O	1 5/8-12	1/2-14	1.20	1.88	0.70	0.70
6405-20-12-O	1 5/8-12	3/4-14	1.20	1.88	0.91	0.91

**6405 STRAIGHT THREAD/FEMALE PIPE
ADAPTER (CON'T)**

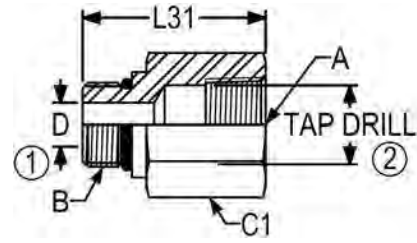

PART NO	B UN/UNF-2A	A NPTF	L31	C1	D	TAP DRILL
6405-20-16-O	1 5/8-12	1-11 1/2	1.20	1.88	1.08	1.14
6405-20-20-O	1 5/8-12	1 1/4-11 1/2	1.95	2.00	1.08	1.48
6405-20-24-O	1 5/8-12	1 1/2-11 1/2	2.27	2.38	1.08	1.72
6405-24-12-O	1 7/8-12	3/4-14	1.00	2.13	0.91	0.91
6405-24-16-O	1 7/8-12	1-11 1/2	1.27	2.13	1.14	1.14
6405-24-20-O	1 7/8-12	1 1/4-11 1/2	1.85	2.13	1.31	1.48
6405-24-24-O	1 7/8-12	1 1/2-11 1/2	2.00	2.38	1.31	1.72
6405-32-20-O	2 1/2-12	1 1/4-11 1/2	1.43	2.75	1.48	1.48
6405-32-24-O	2 1/2-12	1 1/2-11 1/2	1.43	2.75	2.38	1.72
6405-32-32-O	2 1/2-12	2-11 1/2	2.23	2.88	1.78	2.19

6407 STRAIGHT THREAD ADJUSTABLE UNION

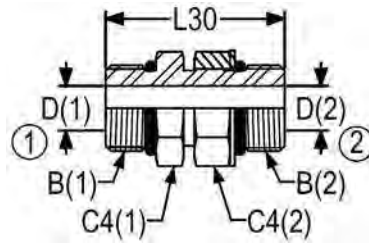

PART NO	B (1) UN/UNF-2A	B (2) UN/UNF-2A	L30	C4 (1)	C4 (2)	D (1)	D (2)
6407-04-04-NWO	7/16-20	7/16-20	1.37	0.56	0.56	0.17	0.17
6407-06-06-NWO	9/16-18	9/16-18	1.50	0.69	0.69	0.30	0.30
6407-08-08-NWO	3/4-16	3/4-16	1.56	0.88	0.88	0.39	0.39
6407-10-06-NWO	7/8-14	9/16-18	1.55	1.00	0.69	0.48	0.30
6407-10-10-NWO	7/8-14	7/8-14	1.80	1.00	1.00	0.48	0.48
6407-12-10-NWO	1 1/16-12	7/8-14	1.97	1.25	1.00	0.61	0.48
6407-12-12-NWO	1 1/16-12	1 1/16-12	2.33	1.25	1.25	0.61	0.61
6407-16-12-NWO	1 5/16-12	1 1/16-12	2.28	1.50	1.25	0.84	0.61
6407-16-16-NWO	1 5/16-12	1 5/16-12	2.28	1.50	1.50	0.84	0.84
6407-20-08-NWO	1 5/8-12	3/4-16	2.08	1.88	0.88	1.08	0.39
6407-20-12-NWO	1 5/8-12	1 1/16-12	2.36	1.88	1.25	1.08	0.61
6407-20-20-NWO	1 5/8-12	1 5/8-12	2.13	1.88	1.88	1.08	1.08
6407-20-24-NWO	1 5/8-12	1 7/8-12	2.50	2.13	2.13	1.08	1.31
6407-24-16-NWO	1 7/8-12	1 5/16-12	2.42	2.13	1.50	1.31	0.84
6407-24-24-NWO	1 7/8-12	1 7/8-12	2.42	2.13	2.13	1.31	1.31
6407-32-32-NWO	2 1/2-12	2 1/2-12	2.59	2.75	2.75	1.78	1.78

6408 HEXAGON HEAD O-RING BOSS PLUG

SAE J514 090109A

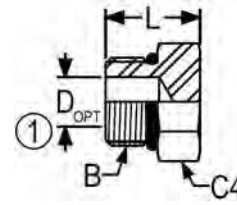

AVAILABLE WITH OR WITHOUT HOLE. CALL CUSTOMER SERVICE FOR AVAILABILITY.

PART NO	B UN/UNF-2A	L	C4	D (OPT)
6408-02-O	5/16-24	0.60	0.44	0.09
6408-03-O	3/8-24	0.60	0.50	0.13
6408-04-O	7/16-20	0.67	0.56	0.20
6408-05-O	1/2-20	0.67	0.63	0.23
6408-06-O	9/16-18	0.73	0.69	0.30
6408-08-O	3/4-16	0.80	0.88	0.42
6408-10-O	7/8-14	0.93	1.00	0.50
6408-12-O	1 1/16-12	1.09	1.25	0.66
6408-14-O	1 3/16-12	1.09	1.38	0.72
6408-16-O	1 5/16-12	1.12	1.50	0.88
6408-20-O	1 5/8-12	1.20	1.88	1.09
6408-24-O	1 7/8-12	1.27	2.13	1.34
6408-32-O	2 1/2-12	1.43	2.75	1.81

6409 HEXAGON SOCKET O-RING BOSS

PLUG

SAE J514 090109B

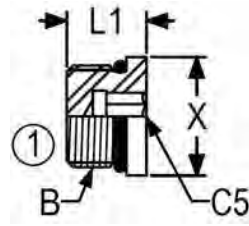

PART NO	B UN/UNF-2A	L1	C5	X
6409-02-O	5/16-24	0.40	0.13	0.44
6409-03-O	3/8-24	0.40	0.13	0.50
6409-04-O	7/16-20	0.47	0.19	0.56
6409-05-O	1/2-20	0.47	0.19	0.63
6409-06-O	9/16-18	0.50	0.25	0.69
6409-08-O	3/4-16	0.58	0.31	0.88
6409-10-O	7/8-14	0.65	0.38	1.00
6409-12-O	1 1/16-12	0.77	0.56	1.25
6409-14-O	1 3/16-12	0.77	0.56	1.38
6408-16-O	1 5/16-12	0.77	0.63	1.50
6409-20-O	1 5/8-12	0.77	0.75	1.88
6409-24-O	1 7/8-12	0.77	0.75	2.13
6409-32-O	2 1/2-12	0.77	0.75	2.75

**6410 STRAIGHT THREAD
REDUCER/EXPANDER**

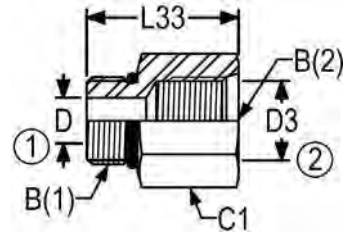

PART NO	B (1) UN/UNF-2A	B (2) UN/UNF-2B	L33	C1	D	D3
6410-04-04-O	7/16-20	7/16-20	1.25	0.69	0.17	0.38
6410-04-06-O	7/16-20	9/16-18	1.20	0.88	0.17	0.50
6410-05-04-O	1/2-20	7/16-20	1.05	0.69	0.23	0.38
6410-06-03-O	9/16-18	3/8-24	0.98	0.75	0.19	0.33
6410-06-04-O	9/16-18	7/16-20	1.03	0.69	0.30	0.38
6410-06-05-O	9/16-18	1/2-20	1.09	0.81	0.30	0.50
6410-06-06-O	9/16-18	9/16-18	1.16	0.88	0.30	0.50
6410-06-08-O	9/16-18	3/4-16	1.32	1.00	0.30	0.68
6410-06-10-O	9/16-18	7/8-14	1.40	1.13	0.30	0.80
6410-06-12-O	9/16-18	1 1/16-12	1.70	1.38	0.30	0.97
6410-08-03-O	3/4-16	3/8-24	0.63	0.88	0.31	0.31
6410-08-04-O	3/4-16	7/16-20	0.80	0.88	0.38	0.38
6410-08-05-O	3/4-16	1/2-20	0.75	0.88	0.45	0.45
6410-08-06-O	3/4-16	9/16-18	1.16	0.88	0.39	0.50
6410-08-08-O	3/4-16	3/4-16	1.31	1.00	0.39	0.68
6410-08-10-O	3/4-16	7/8-14	1.47	1.13	0.39	0.80
6410-08-12-O	3/4-16	1 1/16-12	1.66	1.38	0.39	0.97
6410-10-04-O	7/8-14	7/16-20	0.93	1.00	0.38	0.38
6410-10-06-O	7/8-14	9/16-18	0.93	1.00	0.50	0.50
6410-10-08-O	7/8-14	3/4-16	1.34	1.00	0.48	0.68
6410-10-10-O	7/8-14	7/8-14	1.47	1.13	0.48	0.80
6410-10-12-O	7/8-14	1 1/16-12	1.69	1.38	0.48	0.97
6410-10-16-O	7/8-14	1 5/16-12	1.78	1.63	0.48	1.22
6410-12-04-O	1 1/16-12	7/16-20	1.00	1.25	0.38	0.38
6410-12-06-O	1 1/16-12	9/16-18	1.09	1.25	0.50	0.50
6410-12-08-O	1 1/16-12	3/4-16	1.09	1.25	0.68	0.68
6410-12-10-O	1 1/16-12	7/8-14	1.56	1.25	0.61	0.80
6410-12-12-O	1 1/16-12	1 1/16-12	1.75	1.38	0.61	0.97
6410-12-16-O	1 1/16-12	1 5/16-12	1.81	1.63	0.61	1.22
6410-14-04-O	1 3/16-12	7/16-20	1.20	1.38	0.38	0.38
6410-14-10-O	1 3/16-12	7/8-14	1.09	1.38	0.80	0.80
6410-14-12-O	1 3/16-12	1 1/16-12	1.72	1.38	0.72	0.97
6410-14-16-O	1 3/16-12	1 5/16-12	1.81	1.63	0.72	1.22
6410-16-06-O	1 5/16-12	9/16-18	1.00	1.50	0.50	0.50
6410-16-08-O	1 5/16-12	3/4-16	1.12	1.50	0.68	0.68
6410-16-10-O	1 5/16-12	7/8-14	1.12	1.50	0.80	0.80
6410-16-12-O	1 5/16-12	1 1/16-12	1.70	1.50	0.84	0.97

**6410 STRAIGHT THREAD
REDUCER/EXPANDER (Con't)**

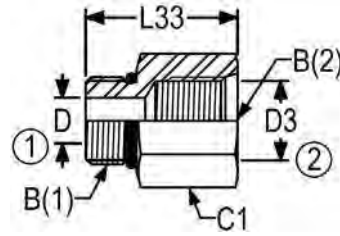

PART NO	B (1) UN/UNF-2A	B (2) UN/UNF-2B	L33	C1	D	D3
6410-16-14-O	1 5/16-12	1 3/16-12	1.72	1.50	0.84	1.10
6410-16-20-O	1 5/16-12	1 5/8-12	2.00	2.00	0.84	1.53
6410-20-06-O	1 5/8-12	9/16-18	1.00	1.88	0.62	0.62
6410-20-10-O	1 5/8-12	7/8-14	1.20	1.88	0.80	0.80
6410-20-12-O	1 5/8-12	1 1/16-12	1.20	1.88	0.97	0.97
6410-20-16-O	1 5/8-12	1 5/16-12	1.20	1.88	1.22	1.22
6410-20-24-O	1 5/8-12	1 7/8-12	1.88	2.25	1.08	1.78
6410-24-06-O	1 7/8-12	9/16-18	1.27	2.13	0.50	0.50
6410-24-08-O	1 7/8-12	3/4-16	1.28	2.13	0.68	0.68
6410-24-12-O	1 7/8-12	1 1/16-12	1.26	2.13	0.97	0.97
6410-24-16-O	1 7/8-12	1 5/16-12	1.27	2.13	1.22	1.22
6410-24-20-O	1 7/8-12	1 5/8-12	1.75	2.13	1.31	1.53
6410-32-06-O	2 1/2-12	9/16-18	1.43	2.75	0.50	0.50
6410-32-08-O	2 1/2-12	3/4-16	1.43	2.75	0.68	0.68
6410-32-12-O	2 1/2-12	1 1/16-12	1.43	2.75	0.96	0.98
6410-32-20-O	2 1/2-12	1 5/8-12	1.43	2.75	1.53	1.72
6410-32-24-O	2 1/2-12	1 7/8-12	1.43	2.75	1.78	1.78

**6801 90 DEGREE STRAIGHT
THREAD ELBOW**
SAE J514 070220
MS51527

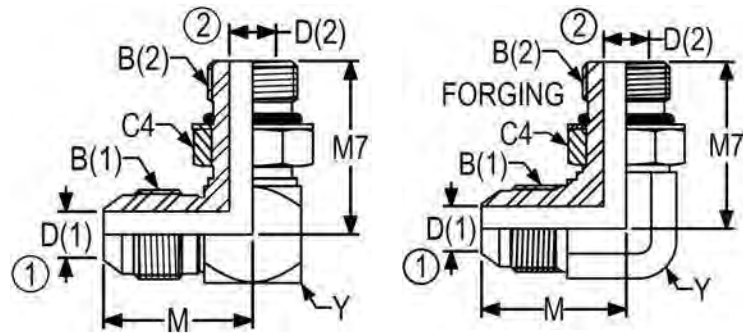

*Non forging parts are brazed construction

PART NO	TUBE OD	B (1) UN/UNF-2A	B (2) UN/UNF-2A	M	M7	C4	Y	D (1)	D (2)
6801-02-02-NWO	1/8	5/16-24	5/16-24	0.77	0.94	0.44	0.44	0.06	0.06
6801-02-02-NWO-FG	1/8	5/16-24	5/16-24	0.77	0.94	0.44	0.44	0.06	0.06
6801-02-04-NWO	1/8	5/16-24	7/16-20	0.81	1.03	0.56	0.50	0.06	0.17
6801-03-03-NWO-FG	3/16	3/8-24	3/8-24	0.83	0.94	0.50	0.44	0.13	0.13
6801-03-05-NWO	3/16	3/8-24	1/2-20	0.89	1.13	0.56	0.56	0.13	0.23
6801-03-06-NWO	3/16	3/8-24	9/16-18	0.92	1.25	0.69	0.63	0.13	0.30
6801-04-02-NWO	1/4	7/16-20	5/16-24	0.89	0.97	0.44	0.50	0.17	0.06
6801-04-02-NWO-FG	1/4	7/16-20	5/16-24	0.89	1.03	0.44	0.44	0.17	0.06
6801-04-03-NWO	1/4	7/16-20	3/8-24	0.89	0.97	0.50	0.50	0.17	0.13
6801-04-03-NWO-FG	1/4	7/16-20	3/8-24	0.89	0.92	0.50	0.44	0.17	0.13
6801-04-04-NWO	1/4	7/16-20	7/16-20	0.89	1.03	0.56	0.50	0.17	0.17
6801-04-04-NWO-FG	1/4	7/16-20	7/16-20	0.89	1.03	0.56	0.44	0.17	0.17
6801-04-05-NWO	1/4	7/16-20	1/2-20	0.92	1.13	0.63	0.56	0.17	0.23
6801-04-05-NWO-FG	1/4	7/16-20	1/2-20	0.95	1.13	0.63	0.56	0.17	0.23
6801-04-06-NWO	1/4	7/16-20	9/16-18	0.95	1.25	0.69	0.63	0.17	0.30
6801-04-06-NWO-FG	1/4	7/16-20	9/16-18	1.05	1.25	0.69	0.56	0.17	0.30
6801-04-08-NWO	1/4	7/16-20	3/4-16	1.05	1.45	0.88	0.81	0.17	0.39
6801-04-08-NWO-FG	1/4	7/16-20	3/4-16	1.12	1.45	0.88	0.75	0.17	0.39
6801-04-10-NWO	1/4	7/16-20	7/8-14	1.11	1.70	1.00	0.94	0.17	0.48
6801-04-12-NWO	1/4	7/16-20	1 1/16-12	1.20	1.94	1.25	1.13	0.17	0.61
6801-05-04-NWO	5/16	1/2-20	7/16-20	0.95	1.06	0.56	0.56	0.23	0.17
6801-05-04-NWO-FG	5/16	1/2-20	7/16-20	0.95	1.13	0.56	0.56	0.23	0.17
6801-05-05-NWO	5/16	1/2-20	1/2-20	0.95	1.13	0.63	0.56	0.23	0.23
6801-05-05-NWO-FG	5/16	1/2-20	1/2-20	0.95	1.13	0.63	0.56	0.23	0.23
6801-05-06-NWO	5/16	1/2-20	9/16-18	0.98	1.25	0.69	0.63	0.23	0.30
6801-05-06-NWO-FG	5/16	1/2-20	9/16-18	1.05	1.25	0.69	0.56	0.23	0.30
6801-05-08-NWO	5/16	1/2-20	3/4-16	1.08	1.45	0.88	0.81	0.23	0.39
6801-05-10-NWO	5/16	1/2-20	7/8-14	1.14	1.70	1.00	0.94	0.23	0.48
6801-06-04-NWO	3/8	9/16-18	7/16-20	1.06	1.09	0.56	0.63	0.30	0.17
6801-06-04-NWO-FG	3/8	9/16-18	7/16-20	1.06	1.19	0.56	0.56	0.30	0.17
6801-06-05-NWO	3/8	9/16-18	1/2-20	1.06	1.16	0.63	0.63	0.30	0.23
6801-06-05-NWO-FG	3/8	9/16-18	1/2-20	1.06	1.19	0.63	0.56	0.30	0.23
6801-06-06-NWO	3/8	9/16-18	9/16-18	1.06	1.25	0.69	0.63	0.30	0.30
6801-06-06-NWO-FG	3/8	9/16-18	9/16-18	1.06	1.25	0.69	0.56	0.30	0.30
6801-06-08-NWO	3/8	9/16-18	3/4-16	1.15	1.45	0.88	0.81	0.30	0.39
6801-06-08-NWO-FG	3/8	9/16-18	3/4-16	1.14	1.45	0.88	0.75	0.30	0.39

**6801 90 DEGREE STRAIGHT
THREAD ELBOW (Con't)**
SAE J514 070220
MS51527

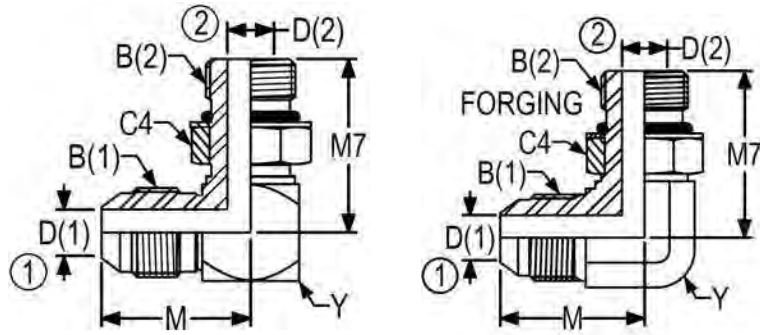

*Non forging parts are brazed construction

PART NO	TUBE OD	B (1) UN/UNF-2A	B (2) UN/UNF-2A	M	M7	C4	Y	D (1)	D (2)
6801-06-10-NWO	3/8	9/16-18	7/8-14	1.22	1.70	1.00	0.94	0.30	0.48
6801-06-10-NWO-FG	3/8	9/16-18	7/8-14	1.22	1.70	1.00	0.88	0.30	0.48
6801-06-12-NWO	3/8	9/16-18	1 1/16-12	1.31	1.94	1.25	1.13	0.30	0.61
6801-06-12-NWO-FG	3/8	9/16-18	1 1/16-12	1.31	1.94	1.25	1.06	0.30	0.61
6801-08-04-NWO	1/2	3/4-16	7/16-20	1.25	1.18	0.56	0.81	0.39	0.17
6801-08-05-NWO	1/2	3/4-16	1/2-20	1.25	1.25	0.63	0.81	0.39	0.23
6801-08-06-NWO	1/2	3/4-16	9/16-18	1.25	1.34	0.69	0.81	0.39	0.30
6801-08-06-NWO-FG	1/2	3/4-16	9/16-18	1.25	1.32	0.69	0.75	0.39	0.30
6801-08-08-NWO	1/2	3/4-16	3/4-16	1.25	1.45	0.88	0.81	0.39	0.39
6801-08-08-NWO-FG	1/2	3/4-16	3/4-16	1.25	1.45	0.88	0.75	0.39	0.39
6801-08-10-NWO	1/2	3/4-16	7/8-14	1.31	1.70	1.00	0.94	0.39	0.48
6801-08-10-NWO-FG	1/2	3/4-16	7/8-14	1.33	1.70	1.00	0.88	0.39	0.48
6801-08-12-NWO	1/2	3/4-16	1 1/16-12	1.40	1.94	1.25	1.13	0.39	0.61
6801-08-12-NWO-FG	1/2	3/4-16	1 1/16-12	1.42	1.94	1.25	1.06	0.39	0.61
6801-08-14-NWO	1/2	3/4-16	1 3/16-12	1.47	2.00	1.38	1.25	0.39	0.72
6801-08-16-NWO	1/2	3/4-16	1 5/16-12	1.53	2.05	1.50	1.38	0.39	0.84
6801-10-06-NWO	5/8	7/8-14	9/16-18	1.45	1.40	0.69	0.94	0.48	0.30
6801-10-06-NWO-FG	5/8	7/8-14	9/16-18	1.45	1.41	0.69	0.88	0.48	0.29
6801-10-08-NWO	5/8	7/8-14	3/4-16	1.45	1.51	0.88	0.94	0.48	0.39
6801-10-08-NWO-FG	5/8	7/8-14	3/4-16	1.45	1.54	0.88	0.88	0.48	0.39
6801-10-10-NWO	5/8	7/8-14	7/8-14	1.45	1.70	1.00	0.94	0.48	0.48
6801-10-10-NWO-FG	5/8	7/8-14	7/8-14	1.45	1.70	1.00	0.88	0.48	0.48
6801-10-12-NWO	5/8	7/8-14	1 1/16-12	1.55	1.94	1.25	1.13	0.48	0.61
6801-10-12-NWO-FG	5/8	7/8-14	1 1/16-12	1.54	1.94	1.25	1.06	0.48	0.61
6801-10-14-NWO	5/8	7/8-14	1 3/16-12	1.61	2.00	1.38	1.25	0.48	0.72
6801-10-16-NWO	5/8	7/8-14	1 5/16-12	1.67	2.05	1.50	1.38	0.48	0.84
6801-10-20-NWO	5/8	7/8-14	1 5/8-12	1.86	2.25	1.88	1.75	0.48	1.08
6801-12-06-NWO	3/4	1 1/16-12	9/16-18	1.66	1.50	0.69	1.13	0.61	0.30
6801-12-08-NWO	3/4	1 1/16-12	3/4-16	1.66	1.61	0.88	1.13	0.61	0.39
6801-12-08-NWO-FG	3/4	1 1/16-12	3/4-16	1.66	1.62	0.88	1.06	0.61	0.39
6801-12-10-NWO	3/4	1 1/16-12	7/8-14	1.66	1.80	1.00	1.13	0.61	0.48
6801-12-10-NWO-FG	3/4	1 1/16-12	7/8-14	1.66	1.78	1.00	1.06	0.61	0.48
6801-12-12-NWO	3/4	1 1/16-12	1 1/16-12	1.66	1.94	1.25	1.13	0.61	0.61
6801-12-12-NWO-FG	3/4	1 1/16-12	1 1/16-12	1.66	1.94	1.25	1.06	0.61	0.61
6801-12-14-NWO	3/4	1 1/16-12	1 3/16-12	1.72	2.00	1.38	1.25	0.61	0.72

**6801 90 DEGREE STRAIGHT
THREAD ELBOW (Con't)**
SAE J514 070220
MS51527

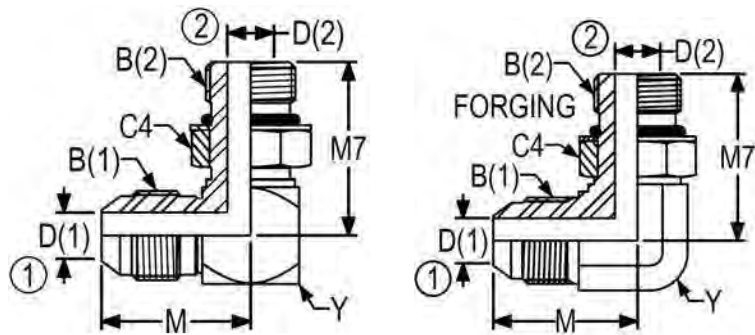

*Non forging parts are brazed construction

PART NO	TUBE OD	B (1) UN/UNF-2A	B (2) UN/UNF-2A	M	M7	C4	Y	D (1)	D (2)
6801-12-16-NWO	3/4	1 1/16-12	1 5/16-12	1.78	2.05	1.50	1.38	0.61	0.84
6801-12-16-NWO-FG	3/4	1 1/16-12	1 5/16-12	1.76	2.05	1.50	1.31	0.61	0.84
6801-12-20-NWO	3/4	1 1/16-12	1 5/8-12	1.97	2.25	1.88	1.75	0.61	1.08
6801-14-12-NWO	7/8	1 3/16-12	1 1/16-12	1.80	2.00	1.25	1.25	0.72	0.61
6801-14-14-NWO	7/8	1 3/16-12	1 3/16-12	1.80	2.00	1.38	1.25	0.72	0.72
6801-14-14-NWO-FG	7/8	1 3/16-12	1 3/16-12	1.80	2.00	1.38	1.31	0.72	0.72
6801-14-16-NWO	7/8	1 3/16-12	1 5/16-12	1.86	2.05	1.50	1.38	0.72	0.84
6801-16-08-NWO	1	1 5/16-12	3/4-16	1.81	1.73	0.88	1.38	0.84	0.39
6801-16-10-NWO	1	1 5/16-12	7/8-14	1.81	1.92	1.00	1.38	0.84	0.48
6801-16-12-NWO	1	1 5/16-12	1 1/16-12	1.81	2.06	1.25	1.38	0.84	0.61
6801-16-12-NWO-FG	1	1 5/16-12	1 1/16-12	1.81	2.05	1.25	1.31	0.84	0.61
6801-16-14-NWO	1	1 5/16-12	1 3/16-12	1.81	2.06	1.38	1.38	0.84	0.72
6801-16-14-NWO-FG	1	1 5/16-12	1 3/16-12	1.81	2.05	1.38	1.31	0.84	0.72
6801-16-16-NWO	1	1 5/16-12	1 5/16-12	1.81	2.05	1.50	1.38	0.84	0.84
6801-16-16-NWO-FG	1	1 5/16-12	1 5/16-12	1.81	2.05	1.50	1.31	0.84	0.84
6801-16-20-NWO	1	1 5/16-12	1 5/8-12	2.00	2.25	1.88	1.75	0.84	1.08
6801-16-20-NWO-FG	1	1 5/16-12	1 5/8-12	2.01	2.25	1.88	1.63	0.84	1.08
6801-16-24-NWO	1	1 5/16-12	1 7/8-12	2.39	2.13	2.13	2.00	0.84	1.31
6801-20-12-NWO	1 1/4	1 5/8-12	1 1/16-12	2.06	2.25	1.25	1.75	1.08	0.61
6801-20-14-NWO	1 1/4	1 5/8-12	1 3/16-12	2.06	2.25	1.38	1.75	1.08	0.72
6801-20-16-NWO	1 1/4	1 5/8-12	1 5/16-12	2.06	2.23	1.50	1.75	1.08	0.84
6801-20-16-NWO-FG	1 1/4	1 5/8-12	1 5/16-12	2.06	2.25	1.50	1.63	1.08	0.84
6801-20-20-NWO	1 1/4	1 5/8-12	1 5/8-12	2.06	2.25	1.88	1.75	1.08	1.08
6801-20-20-NWO-FG	1 1/4	1 5/8-12	1 5/8-12	2.06	2.25	1.88	1.63	1.08	1.08
6801-20-24-NWO	1 1/4	1 5/8-12	1 7/8-12	2.19	2.39	2.13	2.00	1.08	1.31
6801-20-24-NWO-FG	1 1/4	1 5/8-12	1 7/8-12	2.20	2.39	2.13	1.88	1.08	1.31
6801-24-16-NWO	1 1/2	1 7/8-12	1 5/16-12	2.33	2.36	1.50	2.00	1.31	0.84
6801-24-20-NWO	1 1/2	1 7/8-12	1 5/8-12	2.33	2.38	1.88	2.00	1.31	1.08
6801-24-24-NWO	1 1/2	1 7/8-12	1 7/8-12	2.33	2.39	2.13	2.00	1.31	1.31
6801-24-24-NWO-FG	1 1/2	1 7/8-12	1 7/8-12	2.33	2.39	2.13	1.88	1.31	1.31
6801-32-24-NWO	2	2 1/2-12	1 7/8-12	3.06	2.70	2.13	2.63	1.78	1.31
6801-32-24-NWO-FG	2	2 1/2-12	1 7/8-12	3.06	2.89	2.13	2.50	1.31	1.78
6801-32-32-NWO	2	2 1/2-12	2 1/2-12	3.06	2.89	2.75	2.63	1.78	1.78

6801-L 90 DEGREE STRAIGHT THREAD

ELBOW LONG

SAE J514 071520

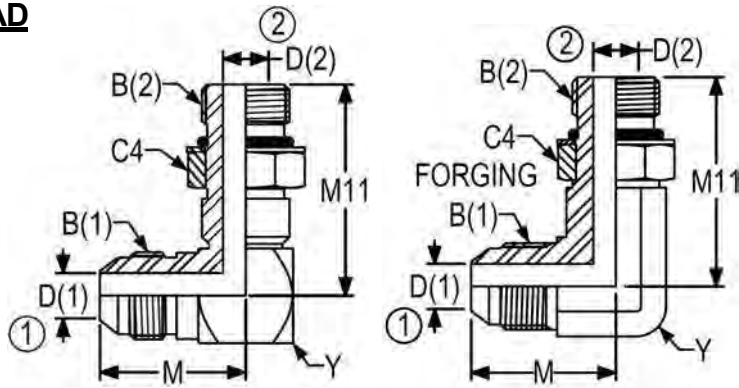

PART NO	TUBE OD	B (1) UN/UNF-2A	B (2) UN/UNF-2A	M	M11	C4	Y	D (1)	D (2)
6801-L-04-04-NWO	1/4	7/16-20	7/16-20	0.89	1.19	0.56	0.50	0.17	0.17
6801-L-04-04-NWO-FG	1/4	7/16-20	7/16-20	0.89	1.19	0.56	0.44	0.17	0.17
6801-L-04-06-NWO	1/4	7/16-20	9/16-18	0.95	1.66	0.69	0.63	0.17	0.30
6801-L-04-12-NWO	1/4	7/16-20	1 1/16-12	1.20	2.47	1.25	1.13	0.17	0.61
6801-L-05-05-NWO	5/16	1/2-20	1/2-20	0.95	1.22	0.63	0.56	0.23	0.23
6801-L-06-06-NWO	3/8	9/16-18	9/16-18	1.06	1.66	0.69	0.63	0.30	0.30
6801-L-06-06-NWO-FG	3/8	9/16-18	9/16-18	1.06	1.66	0.69	0.56	0.30	0.30
6801-L-06-08-NWO	3/8	9/16-18	3/4-16	1.16	1.81	0.88	0.81	0.30	0.39
6801-L-06-10-NWO	3/8	9/16-18	7/8-14	1.22	2.16	1.00	0.94	0.30	0.48
6801-L-08-06-NWO	1/2	3/4-16	9/16-18	1.25	1.75	0.69	0.81	0.39	0.30
6801-L-08-08-NWO	1/2	3/4-16	3/4-16	1.25	1.81	0.88	0.81	0.39	0.39
6801-L-08-08-NWO-FG	1/2	3/4-16	3/4-16	1.25	1.81	0.88	0.75	0.39	0.39
6801-L-08-10-NWO	1/2	3/4-16	7/8-14	1.31	2.16	1.00	0.94	0.39	0.48
6801-L-08-12-NWO	1/2	3/4-16	1 1/16-12	1.41	2.47	1.25	1.13	0.39	0.61
6801-L-10-08-NWO	5/8	7/8-14	3/4-16	1.45	1.88	0.88	0.94	0.48	0.39
6801-L-10-10-NWO	5/8	7/8-14	7/8-14	1.45	2.16	1.00	0.94	0.48	0.48
6801-L-10-10-NWO-FG	5/8	7/8-14	7/8-14	1.45	2.26	1.00	0.88	0.48	0.48
6801-L-10-12-NWO	5/8	7/8-14	1 1/16-12	1.55	2.47	1.25	1.13	0.48	0.61
6801-L-12-10-NWO	3/4	1 1/16-12	7/8-14	1.66	2.25	1.00	1.13	0.61	0.48
6801-L-12-12-NWO	3/4	1 1/16-12	1 1/16-12	1.66	2.47	1.25	1.13	0.61	0.61
6801-L-12-12-NWO-FG	3/4	1 1/16-12	1 1/16-12	1.66	2.47	1.25	1.06	0.61	0.61
6801-L-16-12-NWO	1	1 5/16-12	1 1/16-12	1.81	2.59	1.25	1.38	0.84	0.61
6801-L-16-16-NWO	1	1 5/16-12	1 5/16-12	1.81	3.06	1.50	1.38	0.84	0.84
6801-L-20-20-NWO	1 1/4	1 5/8-12	1 5/8-12	2.06	3.48	1.88	1.75	1.08	1.08

**6801-LL 90 DEGREE STRAIGHT
THREAD ELBOW EXTRA LONG**
SAE J514 071620

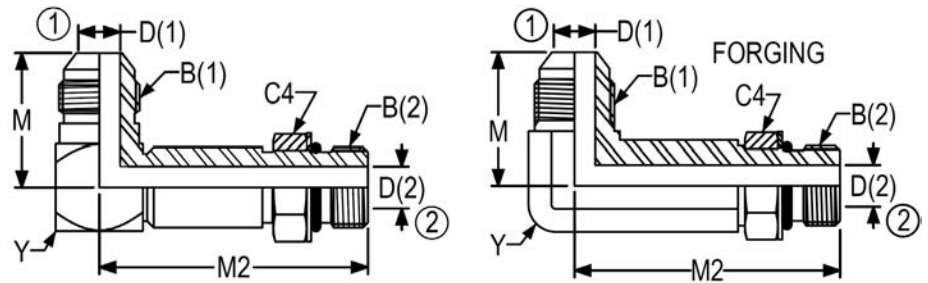

PART NO	TUBE OD	B (1) UN/UNF-2A	B (2) UN/UNF-2A	M	M12	C4	Y	D (1)	D (2)
6801-LL-04-04-NWO	1/4	7/16-20	7/16-20	0.89	1.73	0.56	0.50	0.17	0.17
6801-LL-04-04-NWO-FG	1/4	7/16-20	7/16-20	0.89	1.73	0.56	0.44	0.17	0.17
6801-LL-04-06-NWO	1/4	7/16-20	9/16-18	0.95	2.08	0.69	0.63	0.17	0.30
6801-LL-06-04-NWO	3/8	9/16-18	7/16-20	1.06	1.78	0.56	0.63	0.30	0.17
6801-LL-06-06-NWO	3/8	9/16-18	9/16-18	1.06	2.08	0.69	0.63	0.30	0.30
6801-LL-06-06-NWO-FG	3/8	9/16-18	9/16-18	1.06	2.08	0.69	0.56	0.30	0.30
6801-LL-06-08-NWO	3/8	9/16-18	3/4-16	1.16	2.50	0.88	0.81	0.30	0.39
6801-LL-08-06-NWO	1/2	3/4-16	9/16-18	1.25	2.17	0.69	0.81	0.39	0.30
6801-LL-08-08-NWO	1/2	3/4-16	3/4-16	1.25	2.50	0.88	0.81	0.39	0.39
6801-LL-08-08-NWO-FG	1/2	3/4-16	3/4-16	1.25	2.50	0.88	0.75	0.39	0.39
6801-LL-08-10-NWO	1/2	3/4-16	7/8-14	1.31	3.25	1.00	0.94	0.39	0.48
6801-LL-08-12-NWO	1/2	3/4-16	1 1/16-12	1.41	3.34	1.25	1.13	0.39	0.61
6801-LL-10-08-NWO	5/8	7/8-14	3/4-16	1.45	2.56	0.88	0.94	0.48	0.39
6801-LL-10-10-NWO	5/8	7/8-14	7/8-14	1.45	3.25	1.00	0.94	0.48	0.48
6801-LL-10-12-NWO-FG	5/8	7/8-14	1 1/16-12	1.54	3.34	1.25	1.06	0.48	0.61
6801-LL-12-08-NWO	3/4	1 1/16-12	3/4-16	1.66	2.66	0.88	1.13	0.61	0.39
6801-LL-12-12-NWO	3/4	1 1/16-12	1 1/16-12	1.66	3.34	1.25	1.13	0.61	0.61
6801-LL-12-16-NWO	3/4	1 1/16-12	1 5/16-12	1.78	3.72	1.50	1.38	0.61	0.84
6801-LL-16-10-NWO	1	1 5/16-12	7/8-14	1.81	3.47	1.00	1.38	0.84	0.48
6801-LL-16-12-NWO	1	1 5/16-12	1 1/16-12	1.81	3.47	1.25	1.38	0.84	0.61
6801-LL-16-16-NWO	1	1 5/16-12	1 5/16-12	1.81	3.72	1.50	1.38	0.84	0.84
6801-LL-20-16-NWO	1 1/4	1 5/8-12	1 5/16-12	2.06	3.91	1.50	1.75	1.08	0.84
6801-LL-20-20-NWO	1 1/4	1 5/8-12	1 5/8-12	2.06	4.41	1.88	1.75	1.08	1.08

**6801-LLL 90 DEGREE STRAIGHT THREAD
ELBOW EXTRA EXTRA LONG**

SAE J514 072120 formerly 071720

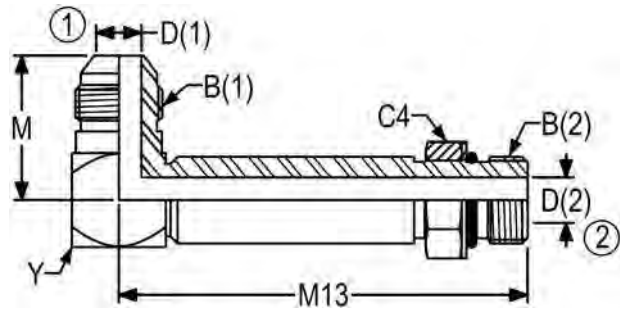

PART NO	TUBE OD	B (1) UN/UNF-2A	B (2) UN/UNF-2A	M	M13	C4	Y	D (1)	D (2)
6801-LLL-04-04-NWO	1/4	7/16-20	7/16-20	0.89	2.44	0.56	0.50	0.17	0.17
6801-LLL-06-06-NWO	3/8	9/16-18	9/16-18	1.06	3.06	0.69	0.63	0.30	0.30
6801-LLL-06-08-NWO	3/8	9/16-18	3/4-16	1.16	3.53	0.88	0.81	0.30	0.39
6801-LLL-08-08-NWO	1/2	3/4-16	3/4-16	1.25	3.53	0.88	0.81	0.39	0.39
6801-LLL-10-10-NWO	5/8	7/8-14	7/8-14	1.45	3.69	1.00	0.94	0.48	0.48
6801-LLL-12-08-NWO	3/4	1 1/16-12	3/4-16	1.66	3.69	0.88	1.13	0.61	0.39
6801-LLL-16-16-NWO	1	1 5/16-12	1 5/16-12	1.81	5.39	1.50	1.38	0.84	0.84

**6802 45 DEGREE STRAIGHT
THREAD ELBOW**
SAE J514 070320
MS51528

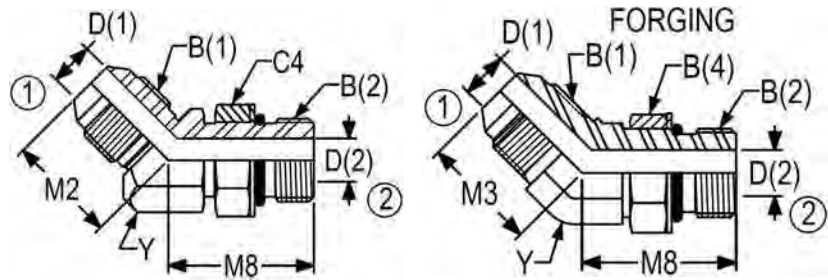

*Non forging parts are brazed construction

PART NO	TUBE OD	B (1) UN/UNF-2A	B (2) UN/UNF-2A	M2	M8	C4	Y	D (1)	D (2)
6802-04-04-NWO	1/4	7/16-20	7/16-20	0.72	1.05	0.56	0.50	0.17	0.17
6802-04-04-NWO-FG	1/4	7/16-20	7/16-20	0.72	1.05	0.56	0.44	0.17	0.17
6802-04-05-NWO	1/4	7/16-20	1/2-20	0.75	1.05	0.63	0.56	0.17	0.23
6802-04-05-NWO-FG	1/4	7/16-20	1/2-20	0.72	1.05	0.63	0.56	0.17	0.23
6802-04-06-NWO	1/4	7/16-20	9/16-18	0.72	1.14	0.69	0.63	0.17	0.30
6802-04-06-NWO-FG	1/4	7/16-20	9/16-18	0.82	1.14	0.56	0.56	0.17	0.30
6802-04-08-NWO	1/4	7/16-20	3/4-16	0.85	1.30	0.88	0.81	0.17	0.39
6802-05-03-NWO	5/16	1/2-20	3/8-24	0.77	0.92	0.56	0.56	0.23	0.13
6802-05-04-NWO	5/16	1/2-20	7/16-20	0.77	0.99	0.56	0.56	0.23	0.17
6802-05-05-NWO	5/16	1/2-20	1/2-20	0.77	1.05	0.63	0.56	0.23	0.23
6802-05-05-NWO-FG	5/16	1/2-20	1/2-20	0.77	1.05	0.63	0.56	0.23	0.23
6802-06-04-NWO	3/8	9/16-18	7/16-20	0.83	1.01	0.56	0.63	0.30	0.17
6802-06-04-NWO-FG	3/8	9/16-18	7/16-20	0.83	1.08	0.56	0.56	0.30	0.17
6802-06-05-NWO	3/8	9/16-18	1/2-20	0.83	1.06	0.63	0.63	0.30	0.23
6802-06-06-NWO	3/8	9/16-18	9/16-18	0.83	1.14	0.69	0.63	0.30	0.30
6802-06-06-NWO-FG	3/8	9/16-18	9/16-18	0.83	1.14	0.69	0.56	0.30	0.30
6802-06-08-NWO	3/8	9/16-18	3/4-16	0.88	1.30	0.88	0.81	0.30	0.39
6802-06-08-NWO-FG	3/8	9/16-18	3/4-16	0.87	1.30	0.88	0.75	0.30	0.39
6802-06-10-NWO	3/8	9/16-18	7/8-14	0.91	1.52	1.00	0.94	0.30	0.48
6802-06-12-NWO	3/8	9/16-18	1 1/16-12	0.93	1.73	1.25	1.13	0.30	0.61
6802-08-04-NWO	1/2	3/4-16	7/16-20	0.98	1.08	0.56	0.81	0.39	0.17
6802-08-05-NWO	1/2	3/4-16	1/2-20	0.98	1.06	0.63	0.81	0.39	0.23
6802-08-06-NWO	1/2	3/4-16	9/16-18	0.98	1.17	0.69	0.81	0.39	0.30
6802-08-06-NWO-FG	1/2	3/4-16	9/16-18	0.98	1.20	0.69	0.75	0.39	0.30
6802-08-08-NWO	1/2	3/4-16	3/4-16	0.98	1.30	0.88	0.81	0.39	0.39
6802-08-08-NWO-FG	1/2	3/4-16	3/4-16	0.98	1.30	0.88	0.75	0.39	0.39
6802-08-10-NWO	1/2	3/4-16	7/8-14	0.99	1.52	1.00	0.94	0.39	0.48
6802-08-10-NWO-FG	1/2	3/4-16	7/8-14	0.99	1.52	1.00	0.88	0.39	0.48
6802-08-12-NWO	1/2	3/4-16	1 1/16-12	1.05	1.73	1.25	1.13	0.39	0.61
6802-10-08-NWO	5/8	7/8-14	3/4-16	1.11	1.36	0.88	0.94	0.48	0.39
6802-10-08-NWO-FG	5/8	7/8-14	3/4-16	1.11	1.36	0.88	0.88	0.48	0.39
6802-10-10-NWO	5/8	7/8-14	7/8-14	1.11	1.52	1.00	0.94	0.48	0.48
6802-10-10-NWO-FG	5/8	7/8-14	7/8-14	1.11	1.52	1.00	0.88	0.48	0.48
6802-10-12-NWO	5/8	7/8-14	1 1/16-12	1.22	1.73	1.25	1.13	0.48	0.61
6802-10-12-NWO-FG	5/8	7/8-14	1 1/16-12	1.16	1.73	1.25	1.06	0.48	0.61
6802-12-08-NWO	3/4	1 1/16-12	3/4-16	1.28	1.41	0.88	1.13	0.61	0.39
6802-12-10-NWO	3/4	1 1/16-12	7/8-14	1.28	1.57	1.00	1.13	0.61	0.48
6802-12-10-NWO-FG	3/4	1 1/16-12	7/8-14	1.28	1.57	1.00	1.06	0.61	0.48

**6802 45 DEGREE STRAIGHT
THREAD ELBOW (Con't)**
SAE J514 070320
MS51528

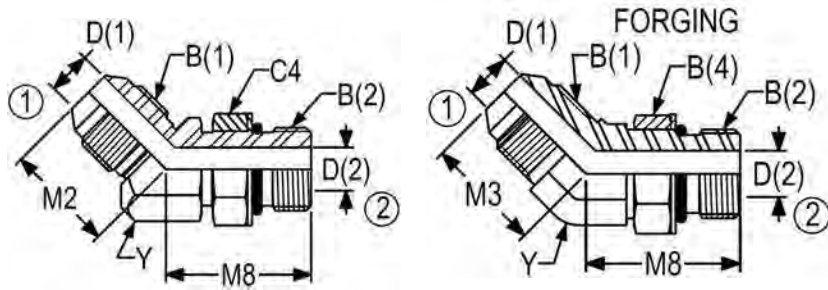

*Non forging parts are brazed construction

PART NO	TUBE OD	B (1) UN/UNF-2A	B (2) UN/UNF-2A	M2	M8	C4	Y	D (1)	D (2)
6802-12-12-NWO	3/4	1 1/16-12	1 1/16-12	1.28	1.73	1.25	1.13	0.61	0.61
6802-12-12-NWO-FG	3/4	1 1/16-12	1 1/16-12	1.28	1.73	1.25	1.06	0.61	0.61
6802-12-14-NWO	3/4	1 1/16-12	1 3/16-12	1.38	1.86	1.38	1.25	0.61	0.72
6802-12-16-NWO	3/4	1 1/16-12	1 5/16-12	1.45	1.86	1.50	1.38	0.61	0.84
6802-12-16-NWO-FG	3/4	1 1/16-12	1 5/16-12	1.42	1.86	1.50	1.31	0.61	0.84
6802-14-12-NWO	7/8	1 3/16-12	1 1/16-12	1.39	1.80	1.25	1.25	0.72	0.61
6802-14-14-NWO	7/8	1 3/16-12	1 3/16-12	1.45	1.86	1.38	1.25	0.72	0.72
6802-16-12-NWO	1	1 5/16-12	1 1/16-12	1.47	1.86	1.25	1.38	0.84	0.61
6802-16-12-NWO-FG	1	1 5/16-12	1 1/16-12	1.47	1.86	1.25	1.31	0.84	0.61
6802-16-14-NWO	1	1 5/16-12	1 3/16-12	1.47	1.86	1.38	1.38	0.84	0.72
6802-16-16-NWO	1	1 5/16-12	1 5/16-12	1.47	1.86	1.50	1.38	0.84	0.84
6802-16-16-NWO-FG	1	1 5/16-12	1 5/16-12	1.47	1.86	1.50	1.31	0.84	0.84
6802-16-20-NWO	1	1 5/16-12	1 5/8-12	1.55	1.91	1.88	1.75	0.84	1.08
6802-16-20-NWO-FG	1	1 5/16-12	1 5/8-12	1.54	1.91	1.88	1.63	0.84	1.08
6802-20-16-NWO	1 1/4	1 5/8-12	1 5/16-12	1.59	1.91	1.50	1.75	1.08	0.84
6802-20-16-NWO-FG	1 1/4	1 5/8-12	1 5/16-12	1.59	1.91	1.50	1.63	1.08	0.84
6802-20-20-NWO	1 1/4	1 5/8-12	1 5/8-12	1.59	1.91	1.88	1.75	1.08	1.08
6802-20-20-NWO-FG	1 1/4	1 5/8-12	1 5/8-12	1.59	1.91	1.88	1.63	1.08	1.08
6802-20-24-NWO	1 1/4	1 5/8-12	1 7/8-12	1.68	1.91	2.13	2.00	1.08	1.31
6802-24-20-NWO	1 1/2	1 7/8-12	1 5/8-12	1.78	1.91	1.88	2.00	1.31	1.08
6802-24-24-NWO	1 1/2	1 7/8-12	1 7/8-12	1.78	1.91	2.13	2.00	1.31	1.31
6802-24-24-NWO-FG	1 1/2	1 7/8-12	1 7/8-12	1.78	1.91	2.13	1.87	1.31	1.31
6802-32-32-NWO	2	2 1/2-12	2 1/2-12	2.22	1.86	2.75	2.63	1.78	1.78

**6803 STRAIGHT THREAD
BRANCH TEE**
SAE J514 070429
MS51529

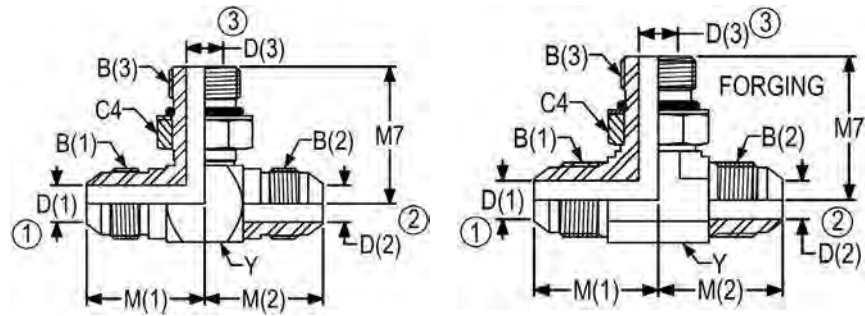

*Non forging parts are brazed construction

PART NO	TUBE OD	B (1) UNUNF-2A	B (2) UNUNF-2A	B (3) UNUNF-2A	M (1)	M (2)	M7	C4
6803-03-03-06-NWO	3/16-3/16	3/8-24	3/8-24	9/16-18	0.92	0.92	1.25	0.69
6803-04-03-06-NWO	1/4-3/16	7/16-20	3/8-20	9/16-18	0.95	0.92	1.25	0.69
6803-04-04-04-NWO	1/4-1/4	7/16-20	7/16-20	7/16-20	0.89	0.89	1.03	0.56
6803-04-04-04-NWO-FG	1/4-1/4	7/16-20	7/16-20	7/16-20	0.89	0.89	1.03	0.56
6803-04-04-06-NWO	1/4-1/4	7/16-20	7/16-20	9/16-18	0.95	0.95	1.25	0.69
6803-05-05-05-NWO	5/16-5/16	1/2-20	1/2-20	1/2-20	0.95	0.95	1.13	0.63
6803-05-05-05-NWO-FG	5/16-5/16	1/2-20	1/2-20	1/2-20	0.95	0.95	1.13	0.63
6803-06-06-04-NWO	3/8-3/8	9/16-18	9/16-18	7/16-20	1.06	1.06	1.09	0.56
6803-06-06-05-NWO	3/8-3/8	9/16-18	9/16-18	1/2-20	1.06	1.06	1.16	0.63
6803-06-06-06-NWO	3/8-3/8	9/16-18	9/16-18	9/16-18	1.06	1.06	1.25	0.69
6803-06-06-06-NWO-FG	3/8-3/8	9/16-18	9/16-18	9/16-18	1.06	1.06	1.25	0.69
6803-06-06-08-NWO	3/8-3/8	9/16-18	9/16-18	3/4-16	1.15	1.15	1.45	0.88
6803-06-06-08-NWO-FG	3/8-3/8	9/16-18	9/16-18	3/4-16	1.14	1.14	1.45	0.88
6803-06-06-12-NWO	3/8-3/8	9/16-18	9/16-18	1 1/16-12	1.31	1.31	1.94	1.25
6803-08-06-06-NWO	1/2-3/8	3/4-16	9/16-18	9/16-18	1.25	1.15	1.34	0.69
6803-08-06-08-NWO	1/2-3/8	3/4-16	9/16-18	3/4-16	1.25	1.15	1.45	0.88
6803-08-08-06-NWO	1/2-1/2	3/4-16	3/4-16	9/16-18	1.25	1.25	1.34	0.69

PART NO	Y	D (1)	D (2)	D (3)
6803-03-03-06-NWO	0.63	0.13	0.13	0.30
6803-04-03-06-NWO	0.63	0.13	0.17	0.30
6803-04-04-04-NWO	0.50	0.17	0.17	0.17
6803-04-04-04-NWO-FG	0.44	0.17	0.17	0.17
6803-04-04-06-NWO	0.63	0.17	0.17	0.30
6803-05-05-05-NWO	0.56	0.23	0.23	0.23
6803-05-05-05-NWO-FG	0.56	0.23	0.23	0.23
6803-06-06-04-NWO	0.63	0.30	0.30	0.17
6803-06-06-05-NWO	0.63	0.30	0.30	0.23
6803-06-06-06-NWO	0.63	0.30	0.30	0.30
6803-06-06-06-NWO-FG	0.56	0.30	0.30	0.30
6803-06-06-08-NWO	0.81	0.30	0.30	0.39
6803-06-06-08-NWO-FG	0.75	0.30	0.30	0.39
6803-06-06-12-NWO	1.13	0.30	0.30	0.61
6803-08-06-06-NWO	0.81	0.39	0.30	0.30
6803-08-06-08-NWO	0.81	0.39	0.30	0.39
6803-08-08-06-NWO	0.81	0.39	0.39	0.30

6803 STRAIGHT THREAD

BRANCH TEE (Con't)

SAE J514 070429

MS51529

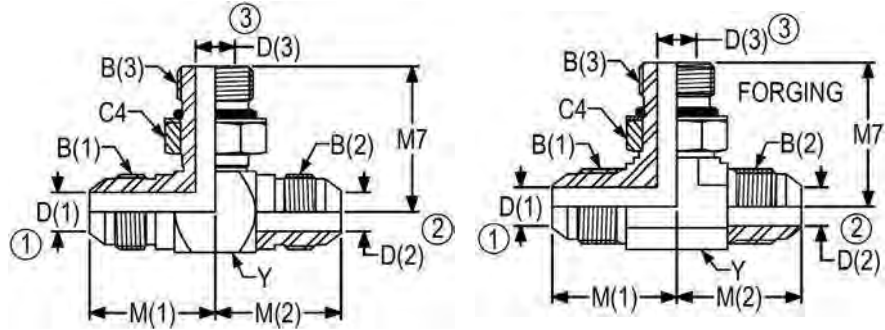

*Non forging parts are brazed construction

PART NO	TUBE OD	B (1) UNUNF-2A	B (2) UNUNF-2A	B (3) UNUNF-2A	M (1)	M (2)	M7	C4
6803-08-08-08-NWO	1/2-1/2	3/4-16	3/4-16	3/4-16	1.25	1.25	1.45	0.88
6803-08-08-08-NWO-FG	1/2-1/2	3/4-16	3/4-16	3/4-16	1.25	1.25	1.45	0.88
6803-08-08-10-NWO	1/2-1/2	3/4-16	3/4-16	7/8-14	1.31	1.31	1.70	1.00
6803-08-08-12-NWO	1/2-1/2	3/4-16	3/4-16	1 1/16-12	1.40	1.40	1.94	0.88
6803-10-08-08-NWO	5/8-1/2	7/8-14	3/4-16	3/4-16	1.45	1.31	1.51	0.88
6803-10-08-10-NWO	5/8-1/2	7/8-14	3/4-16	7/8-14	1.45	1.31	1.70	1.00
6803-10-10-06-NWO	5/8-5/8	7/8-14	7/8-14	9/16-18	1.45	1.45	1.40	0.69
6803-10-10-08-NWO	5/8-5/8	7/8-14	7/8-14	3/4-16	1.45	1.45	1.51	0.88
6803-10-10-10-NWO	5/8-5/8	7/8-14	7/8-14	7/8-14	1.45	1.45	1.70	1.00
6803-10-10-10-NWO-FG	5/8-5/8	7/8-14	7/8-14	7/8-14	1.45	1.45	1.70	1.00
6803-10-10-12-NWO	5/8-5/8	7/8-14	7/8-14	1 1/16-12	1.55	1.55	1.94	1.25
6803-10-10-12-NWO-FG	5/8-5/8	7/8-14	7/8-14	1 1/16-12	1.54	1.54	1.94	1.25
6803-10-10-16-NWO	5/8-5/8	7/8-14	7/8-14	1 5/16-12	1.67	1.67	2.05	1.50
6803-12-04-12-NWO	3/4-1/4	1 1/16-12	7/16-20	1 1/16-12	1.66	1.20	1.94	1.25
6803-12-06-10-NWO	3/4-3/8	1 1/16-12	9/16-18	7/8-14	1.66	1.31	1.80	1.00
6803-12-08-12-NWO	3/4-1/2	1 1/16-12	3/4-16	1 1/16-12	1.66	1.41	1.94	1.25
6803-12-08-12-NWO-FG	3/4-1/2	1 1/16-12	3/4-16	1 1/16-12	1.66	1.42	1.94	1.25

PART NO	Y	D (1)	D (2)	D (3)
6803-08-08-08-NWO	0.81	0.39	0.39	0.39
6803-08-08-08-NWO-FG	0.75	0.39	0.39	0.39
6803-08-08-10-NWO	0.94	0.39	0.39	0.48
6803-08-08-12-NWO	1.13	0.39	0.39	0.61
6803-10-08-08-NWO	0.94	0.48	0.39	0.39
6803-10-08-10-NWO	0.94	0.48	0.39	0.48
6803-10-10-06-NWO	0.94	0.48	0.48	0.30
6803-10-10-08-NWO	0.94	0.48	0.48	0.39
6803-10-10-10-NWO	0.94	0.48	0.48	0.48
6803-10-10-10-NWO-FG	0.88	0.48	0.48	0.48
6803-10-10-12-NWO	1.13	0.48	0.48	0.61
6803-10-10-12-NWO-FG	1.06	0.48	0.48	0.61
6803-10-10-16-NWO	1.38	0.48	0.48	0.84
6803-12-04-12-NWO	1.13	0.61	0.17	0.61
6803-12-06-10-NWO	1.13	0.61	0.30	0.48
6803-12-08-12-NWO	1.13	0.61	0.39	0.61
6803-12-08-12-NWO-FG	1.06	0.61	0.39	0.61

**6803 STRAIGHT THREAD
BRANCH TEE (Con't)**
SAE J514 070429
MS51529

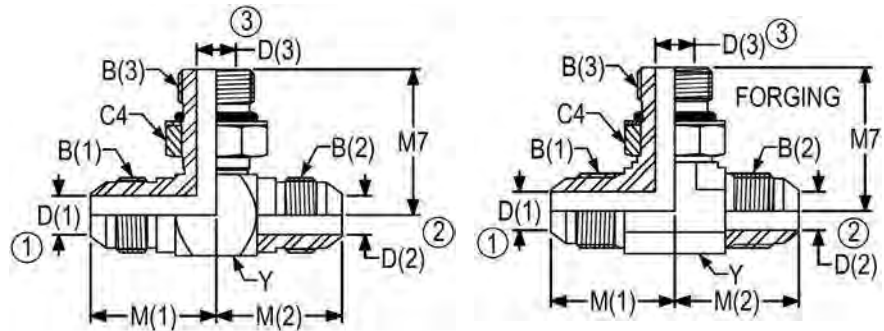

*Non forging parts are brazed construction

PART NO	TUBE OD	B (1) UNUNF-2A	B (2) UNUNF-2A	B (3) UNUNF-2A	M (1)	M (2)	M7	C4
6803-12-08-16-NWO	3/4-1/2	1 1/16-12	3/4-16	1 5/16-12	1.78	1.53	2.05	1.50
6803-12-10-12-NWO	3/4-5/8	1 1/16-12	7/8-14	1 1/16-12	1.66	1.55	1.94	1.25
6803-12-10-12-NWO-FG	3/4-5/8	1 1/16-12	7/8-14	1 1/16-12	1.66	1.54	1.94	1.25
6803-12-12-06-NWO	3/4-3/4	1 1/16-12	1 1/16-12	9/16-18	1.66	1.66	1.50	0.69
6803-12-12-08-NWO	3/4-3/4	1 1/16-12	1 1/16-12	3/4-16	1.66	1.66	1.61	0.88
6803-12-12-10-NWO	3/4-3/4	1 1/16-12	1 1/16-12	7/8-14	1.66	1.66	1.80	1.00
6803-12-12-10-NWO-FG	3/4-3/4	1 1/16-12	1 1/16-12	7/8-14	1.66	1.66	1.89	1.00
6803-12-12-12-NWO	3/4-3/4	1 1/16-12	1 1/16-12	1 1/16-12	1.66	1.66	1.94	1.25
6803-12-12-12-NWO-FG	3/4-3/4	1 1/16-12	1 1/16-12	1 1/16-12	1.65	1.65	1.94	1.25
6803-12-12-16-NWO	3/4-3/4	1 1/16-12	1 1/16-12	1 5/16-12	1.78	1.78	2.05	1.50
6803-14-14-14-NWO	7/8-7/8	1 3/16-12	1 3/16-12	1 3/16-12	1.80	1.80	2.00	1.38
6803-16-06-10-NWO	1-3/8	1 5/16-12	9/16-18	7/8-14	1.81	1.44	1.92	1.00
6803-16-06-16-NWO	1-3/8	1 5/16-12	9/16-18	1 5/16-12	1.81	1.44	2.05	1.50
6803-16-10-10-NWO	1-5/8	1 5/16-12	7/8-14	7/8-14	1.81	1.67	1.92	1.00
6803-16-12-12-NWO	1-3/4	1 5/16-12	1 1/16-12	1 1/16-12	1.81	1.79	2.06	1.25
6803-16-12-16-NWO	1-3/4	1 5/16-12	1 1/16-12	1 5/16-12	1.81	1.78	2.05	1.50

PART NO	Y	D (1)	D (2)	D (3)
6803-12-08-16-NWO	1.38	0.61	0.39	0.84
6803-12-10-12-NWO	1.13	0.61	0.48	0.61
6803-12-10-12-NWO-FG	1.06	0.61	0.48	0.61
6803-12-12-10-NWO-FG	1.06	0.61	0.61	0.48
6803-12-12-16-NWO	1.38	0.61	0.61	0.84
6803-12-12-12-NWO	1.13	0.61	0.61	0.61
6803-12-12-12-NWO-FG	1.06	0.61	0.61	0.61
6803-12-12-06-NWO	1.13	0.61	0.61	0.30
6803-12-12-08-NWO	1.13	0.61	0.61	0.39
6803-12-12-10-NWO	1.13	0.61	0.61	0.48
6803-14-14-14-NWO	1.25	0.72	0.72	0.72
6803-16-06-10-NWO	1.38	0.84	0.30	0.48
6803-16-06-16-NWO	1.38	0.84	0.30	0.84
6803-16-10-10-NWO	1.38	0.84	0.48	0.48
6803-16-12-12-NWO	1.38	0.84	0.61	0.61
6803-16-12-16-NWO	1.38	0.84	0.61	0.84

6803 STRAIGHT THREAD

BRANCH TEE (Con't)

SAE J514 070429

MS51529

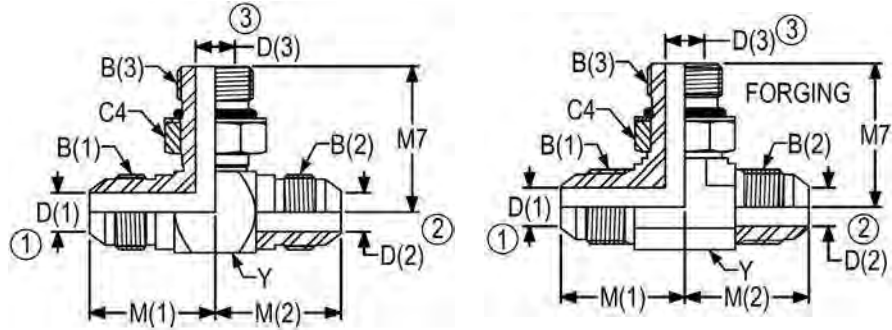

*Non forging parts are brazed construction

PART NO	TUBE OD	B (1) UNUNF-2A	B (2) UNUNF-2A	B (3) UNUNF-2A	M (1)	M (2)	M7	C4
6803-16-16-16-NWO	1-1	1 5/16-12	1 5/16-12	1 5/16-12	1.81	1.81	2.05	1.50
6803-16-16-16-NWO-FG	1-1	1 5/16-12	1 5/16-12	1 5/16-12	1.81	1.81	2.05	1.50
6803-20-16-16-NWO	1 1/4-1	1 5/8-12	1 5/16-12	1 5/16-12	2.06	2.00	2.23	1.50
6803-20-16-20-NWO	1 1/4-1	1 5/8-12	1 5/16-12	1 5/8-12	2.06	2.00	2.25	1.88
6803-20-20-12-NWO	1 1/4-1 1/4	1 5/8-12	1 5/8-12	1 1/16-12	2.06	2.06	2.25	1.25
6803-20-20-16-NWO	1 1/4-1 1/4	1 5/8-12	1 5/8-12	1 5/16-12	2.06	2.06	2.23	1.50
6803-20-20-20-NWO	1 1/4-1 1/4	1 5/8-12	1 5/8-12	1 5/8-12	2.06	2.06	2.25	1.88
6803-20-20-20-NWO-FG	1 1/4-1 1/4	1 5/8-12	1 5/8-12	1 5/8-12	2.06	2.06	2.25	1.88
6803-24-24-24-NWO	1 1/2-1 1/2	1 7/8-12	1 7/8-12	1 7/8-12	2.33	2.33	2.39	2.13
6803-32-32-32-NWO	2-2	2 1/2-12	2 1/2-12	2 1/2-12	3.06	3.06	2.89	2.75
6803-32-32-32-NWO-FG	2-2	2 1/2-12	2 1/2-12	2 1/2-12	3.06	3.06	2.89	2.75

PART NO	Y	D (1)	D (2)	D (3)
6803-16-16-16-NWO	1.38	0.84	0.84	0.84
6803-16-16-16-NWO-FG	1.31	0.84	0.84	0.84
6803-20-16-16-NWO	1.75	1.08	0.84	0.84
6803-20-16-20-NWO	1.75	1.08	0.84	1.08
6803-20-20-12-NWO	1.75	1.08	1.08	0.61
6803-20-20-16-NWO	1.75	1.08	1.08	0.84
6803-20-20-20-NWO	1.75	1.08	1.08	1.08
6803-20-20-20-NWO-FG	1.63	1.08	1.08	1.08
6803-24-24-24-NWO	2.00	1.31	1.31	1.31
6803-32-32-32-NWO	2.50	1.78	1.78	1.78
6803-32-32-32-NWO-FG	2.50	1.78	1.78	1.78

6804 STRAIGHT THREAD

RUN TEE

SAE J514 070428

MS51530

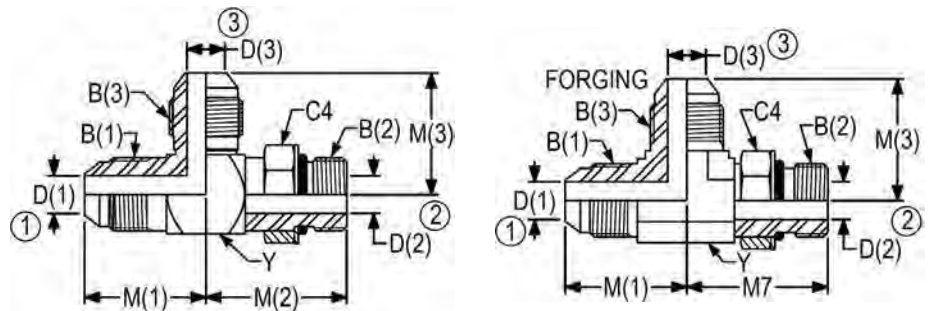

Non forging parts are brazed construction

PART NO	TUBE OD	B (1) UN/UNF-2A	B (2) UN/UNF-2A	B (3) UN/UNF-2A	M (1)	M7	M (3)
6804-04-04-04-NWO	1/4-1/4	7/16-20	7/16-20	7/16-20	0.89	1.03	0.89
6804-04-04-04-NWO-FG	1/4-1/4	7/16-20	7/16-20	7/16-20	0.89	1.03	0.89
6804-04-06-04-NWO	1/4-1/4	7/16-20	9/16-18	7/16-20	0.95	1.25	0.95
6804-04-06-06-NWO	1/4-3/8	7/16-20	9/16-18	9/16-18	0.95	1.25	1.06
6804-04-06-06-NWO-FG	1/4-3/8	7/16-20	9/16-18	9/16-18	1.05	1.25	1.06
6804-04-08-06-NWO	1/4-3/8	7/16-20	3/4-16	9/16-18	1.05	1.45	1.15
6804-04-10-08-NWO	1/4-1/2	7/16-20	7/8-14	3/4-16	1.11	1.70	1.31
6804-04-10-10-NWO	1/4-5/8	7/16-20	7/8-14	7/8-14	1.11	1.70	1.45
6804-05-04-05-NWO	5/16-5/16	1/2-20	7/16-20	1/2-20	0.95	1.06	0.95
6804-05-05-03-NWO	5/16-	1/2-20	1/2-20	3/8-24	0.95	1.13	0.89
6804-05-05-05-NWO	5/16-5/16	1/2-20	1/2-20	1/2-20	0.95	1.13	0.95
6804-05-05-05-NWO-FG	5/16-	1/2-20	1/2-20	1/2-20	0.95	1.13	0.95
6804-06-04-06-NWO	3/8-3/8	9/16-18	7/16-20	9/16-18	1.06	1.09	1.06
6804-06-06-04-NWO	3/8-1/4	9/16-18	9/16-18	7/16-20	1.06	1.25	0.95
6804-06-06-05-NWO	3/8-3/8	9/16-18	9/16-18	1/2-20	1.06	1.25	0.98
6804-06-06-06-NWO	3/8-3/8	9/16-18	9/16-18	9/16-18	1.06	1.25	1.06
6804-06-06-06-NWO-FG	3/8-3/8	9/16-18	9/16-18	9/16-18	1.06	1.25	1.06
6804-06-06-08-NWO	3/8-1/2	9/16-18	9/16-18	3/4-16	1.15	1.34	1.25

PART NO	C4	Y	D (1)	D (2)	D (3)
6804-04-04-04-NWO	0.56	0.50	0.17	0.17	0.17
6804-04-04-04-NWO-FG	0.56	0.44	0.17	0.17	0.17
6804-04-06-04-NWO	0.69	0.63	0.17	0.30	0.17
6804-04-06-06-NWO	0.69	0.63	0.17	0.30	0.30
6804-04-06-06-NWO-FG	0.69	0.56	0.17	0.30	0.30
6804-04-08-06-NWO	0.88	0.81	0.17	0.39	0.30
6804-04-10-08-NWO	1.00	0.94	0.17	0.48	0.39
6804-04-10-10-NWO	1.00	0.94	0.17	0.48	0.48
6804-05-04-05-NWO	0.56	0.56	0.23	0.17	0.23
6804-05-05-03-NWO	0.63	0.56	0.23	0.23	0.13
6804-05-05-05-NWO	0.63	0.56	0.23	0.23	0.23
6804-05-05-05-NWO-FG	0.63	0.56	0.23	0.23	0.23
6804-06-04-06-NWO	0.56	0.63	0.30	0.17	0.30
6804-06-06-04-NWO	0.69	0.63	0.30	0.30	0.17
6804-06-06-05-NWO	0.69	0.63	0.30	0.30	0.23
6804-06-06-06-NWO	0.69	0.63	0.30	0.30	0.30
6804-06-06-06-NWO-FG	0.69	0.56	0.30	0.30	0.30
6804-06-06-08-NWO	0.69	0.81	0.30	0.30	0.39

6804 STRAIGHT THREAD

RUN TEE (Con't)

SAE J514 070428

MS51530

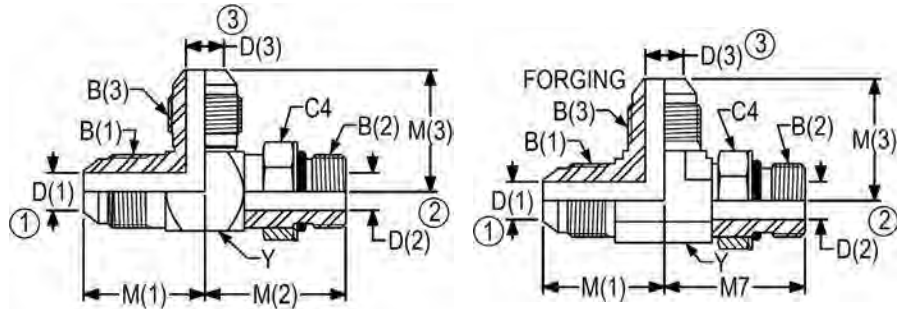

Non forging parts are brazed construction

PART NO	TUBE OD	B (1) UN/UNF-2A	B (2) UN/UNF-2A	B (3) UN/UNF-2A	M (1)	M7	M (3)
6804-06-08-06-NWO	3/8-3/8	9/16-18	3/4-16	9/16-18	1.15	1.45	1.15
6804-06-08-08-NWO	3/8-1/2	9/16-18	3/4-16	3/4-16	1.15	1.45	1.25
6804-06-12-08-NWO	3/8-1/2	9/16-18	1 1/16-12	3/4-16	1.31	1.94	1.40
6804-06-12-12-NWO	3/8-3/4	9/16-18	1 1/16-12	1 1/16-12	1.31	1.94	1.66
6804-06-16-16-NWO	3/8-1	9/16-18	1 5/16-12	1 5/16-12	1.44	2.05	1.81
6804-08-06-08-NWO	1/2-1/2	3/4-16	9/16-18	3/4-16	1.25	1.34	1.25
6804-08-08-04-NWO	1/2-1/4	3/4-16	3/4-16	7/16-20	1.25	1.45	1.05
6804-08-08-04-NWO-FG	1/2-1/2	3/4-16	3/4-16	7/16-20	1.25	1.45	1.00
6804-08-08-08-NWO	1/2-1/2	3/4-16	3/4-16	3/4-16	1.25	1.45	1.25
6804-08-08-08-NWO-FG	1/2-1/2	3/4-16	3/4-16	3/4-16	1.25	1.45	1.25
6804-08-10-04-NWO	1/2-1/4	3/4-16	7/8-14	7/16-20	1.31	1.70	1.11
6804-08-10-08-NWO	1/2-1/2	3/4-16	7/8-14	3/4-16	1.31	1.70	1.31
6804-08-12-04-NWO	1/2-1/4	3/4-16	1 1/16-12	7/16-20	1.40	1.94	1.20
6804-08-12-08-NWO	1/2-1/2	3/4-16	1 1/16-12	3/4-16	1.40	1.94	1.40
6804-10-08-08-NWO	5/8-1/2	7/8-14	3/4-16	3/4-16	1.45	1.51	1.31
6804-10-08-10-NWO	5/8-5/8	7/8-14	3/4-16	7/8-14	1.45	1.51	1.45
6804-10-10-04-NWO	5/8-1/4	7/8-14	7/8-14	7/16-20	1.45	1.70	1.11

PART NO	C4	Y	D (1)	D (2)	D (3)
6804-06-08-06-NWO	0.88	0.81	0.30	0.39	0.30
6804-06-08-08-NWO	0.88	0.81	0.30	0.39	0.39
6804-06-12-08-NWO	1.25	1.13	0.30	0.61	0.39
6804-06-12-12-NWO	1.25	1.13	0.30	0.61	0.61
6804-06-16-16-NWO	1.50	1.38	0.30	0.84	0.84
6804-08-06-08-NWO	0.69	0.81	0.39	0.30	0.39
6804-08-08-04-NWO	0.88	0.81	0.39	0.39	0.17
6804-08-08-04-NWO-FG	0.88	0.75	0.39	0.39	0.17
6804-08-08-08-NWO	0.88	0.81	0.39	0.39	0.39
6804-08-08-08-NWO-FG	0.88	0.75	0.39	0.39	0.39
6804-08-10-04-NWO	1.00	0.94	0.39	0.48	0.17
6804-08-10-08-NWO	1.00	0.94	0.39	0.48	0.39
6804-08-12-04-NWO	1.25	1.13	0.39	0.61	0.17
6804-08-12-08-NWO	1.25	1.13	0.39	0.61	0.39
6804-10-08-08-NWO	0.88	0.94	0.48	0.39	0.39
6804-10-08-10-NWO	0.88	0.94	0.48	0.39	0.48
6804-10-10-04-NWO	1.00	0.94	0.48	0.48	0.17

6804 STRAIGHT THREAD

RUN TEE (Con't)

SAE J514 070428

MS51530

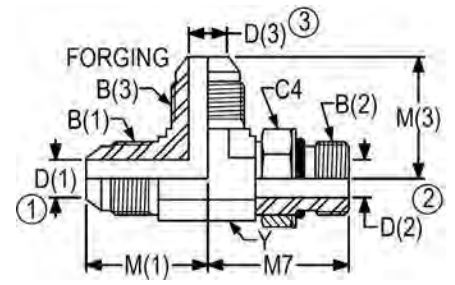
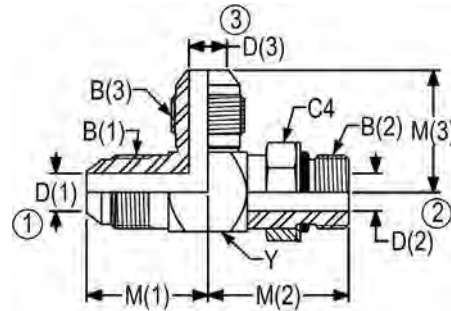

Non forging parts are brazed construction

PART NO	TUBE OD	B (1) UNUNF-2A	B (2) UNUNF-2A	B (3) UNUNF-2A	M (1)	M7	M (3)
6804-10-10-10-NWO	5/8-5/8	7/8-14	7/8-14	7/8-14	1.45	1.70	1.45
6804-10-10-10-NWO-FG	5/8-5/8	7/8-14	7/8-14	7/8-14	1.45	1.70	1.45
6804-10-10-12-NWO	5/8-3/4	7/8-14	7/8-14	1 1/16-12	1.55	1.80	1.66
6804-10-12-10-NWO	5/8-5/8	7/8-14	1 1/16-12	7/8-14	1.55	1.94	1.55
6804-10-12-10-NWO-FG	5/8-3/4	7/8-14	1 1/16-12	7/8-14	1.54	1.94	1.54
6804-10-12-12-NWO	5/8-3/4	7/8-14	1 1/16-12	1 1/16-12	1.55	1.94	1.66
6804-10-12-16-NWO	5/8-1	7/8-14	1 1/16-12	1 5/16-12	1.67	2.06	1.81
6804-10-16-10-NWO	5/8-5/8	7/8-14	1 5/16-12	7/8-14	1.67	2.05	1.67
6804-12-08-12-NWO	3/4-3/4	1 1/16-12	3/4-16	1 1/16-12	1.66	1.61	1.66
6804-12-10-08-NWO	3/4-1/2	1 1/16-12	7/8-14	3/4-16	1.66	1.80	1.40
6804-12-10-12-NWO	3/4-3/4	1 1/16-12	7/8-14	1 1/16-12	1.66	1.80	1.66
6804-12-10-12-NWO-FG	3/4-5/8	1 1/16-12	7/8-14	1 1/16-12	1.66	1.78	1.66
6804-12-12-04-NWO	3/4-1/4	1 1/16-12	1 1/16-12	7/16-20	1.66	1.94	1.20
6804-12-12-06-NWO	3/4-3/8	1 1/16-12	1 1/16-12	9/16-18	1.66	1.94	1.31
6804-12-12-06-NWO-FG	3/4-3/4	1 1/16-12	1 1/16-12	9/16-18	1.66	1.94	1.31
6804-12-12-08-NWO-FG	3/4-3/4	1 1/16-12	1 1/16-12	3/4-16	1.66	1.94	1.42
6804-12-12-10-NWO	3/4-5/8	1 1/16-12	1 1/16-12	7/8-14	1.66	1.94	1.55

PART NO	C4	Y	D (1)	D (2)	D (3)
6804-10-10-10-NWO	1.00	0.94	0.48	0.48	0.48
6804-10-10-10-NWO-FG	1.00	0.88	0.48	0.48	0.48
6804-10-10-12-NWO	1.00	1.13	0.48	0.48	0.61
6804-10-12-10-NWO	1.25	1.13	0.48	0.61	0.48
6804-10-12-10-NWO-FG	1.25	1.06	0.48	0.61	0.48
6804-10-12-12-NWO	1.25	1.13	0.48	0.61	0.61
6804-10-12-16-NWO	1.25	1.38	0.48	0.61	0.84
6804-10-16-10-NWO	1.50	1.38	0.48	0.84	0.48
6804-12-08-12-NWO	0.88	1.13	0.61	0.39	0.61
6804-12-10-08-NWO	1.00	1.13	0.61	0.48	0.39
6804-12-10-12-NWO	1.00	1.13	0.61	0.48	0.61
6804-12-10-12-NWO-FG	1.00	1.06	0.61	0.48	0.61
6804-12-12-04-NWO	1.25	1.13	0.61	0.61	0.17
6804-12-12-06-NWO	1.25	1.13	0.61	0.61	0.30
6804-12-12-06-NWO-FG	1.25	1.06	0.61	0.61	0.30
6804-12-12-08-NWO-FG	1.25	1.06	0.61	0.61	0.39
6804-12-12-10-NWO	1.25	1.13	0.61	0.61	0.48

6804 STRAIGHT THREAD

RUN TEE (Con't)

SAE J514 070428

MS51530

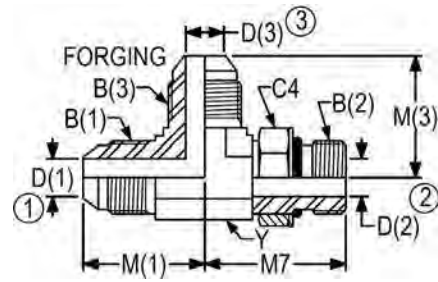
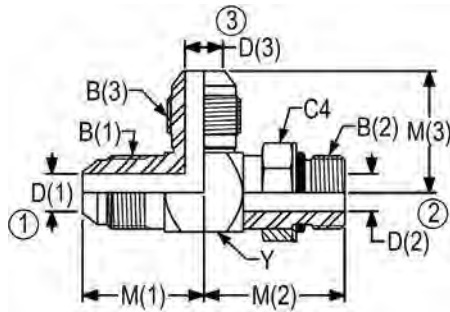

Non forging parts are brazed construction

PART NO	TUBE OD	B (1) UNUNF-2A	B (2) UNUNF-2A	B (3) UNUNF-2A	M (1)	M7	M (3)
6804-12-12-12-NWO	3/4-3/4	1 1/16-12	1 1/16-12	1 1/16-12	1.66	1.94	1.66
6804-12-12-16-NWO	3/4-1	1 1/16-12	1 1/16-12	1 5/16-12	1.78	2.06	1.81
6804-12-14-06-NWO	3/4-3/8	1 1/16-12	1 3/16-12	9/16-18	1.72	2.00	1.38
6804-12-16-05-NWO	3/4-5/16	1 1/16-12	1 5/16-12	1/2-20	1.78	2.05	1.36
6804-12-16-12-NWO	3/4-3/4	1 1/16-12	1 5/16-12	1 1/16-12	1.78	2.05	1.78
6804-12-16-12-NWO-FG	3/4-1	1 1/16-12	1 5/16-12	1 1/16-12	1.76	2.05	1.76
6804-12-16-16-NWO	3/4-1	1 1/16-12	1 5/16-12	1 5/16-12	1.78	2.05	1.81
6804-12-16-20-NWO	3/4-1	1 1/16-12	1 5/16-12	1 5/8-12	1.97	2.24	2.06
6804-12-20-16-NWO	3/4-1	1 1/16-12	1 5/8-12	1 5/16-12	1.97	2.25	2.00
6804-14-14-14-NWO	7/8-7/8	1 3/16-12	1 3/16-12	1 3/16-12	1.80	2.00	1.80
6804-16-10-16-NWO	1-1	1 5/16-12	7/8-14	1 5/16-12	1.81	1.92	1.81
6804-16-12-12-NWO	1-3/4	1 5/16-12	1 1/16-12	1 1/16-12	1.81	2.06	1.78
6804-16-12-16-NWO	1-1	1 5/16-12	1 1/16-12	1 5/16-12	1.81	2.06	1.81
6804-16-14-16-NWO	1-1	1 5/16-12	1 3/16-12	1 5/16-12	1.81	2.06	1.81
6804-16-16-04-NWO	1-1/4	1 5/16-12	1 5/16-12	7/16-20	1.81	2.05	1.33
6804-16-16-08-NWO	1-1/2	1 5/16-12	1 5/16-12	3/4-16	1.81	2.05	1.53
6804-16-16-10-NWO	1-5/8	1 5/16-12	1 5/16-12	7/8-14	1.81	2.05	1.67

PART NO	C4	Y	D (1)	D (2)	D (3)
6804-12-12-12-NWO	1.25	1.13	0.61	0.61	0.61
6804-12-12-16-NWO	1.25	1.38	0.61	0.61	0.84
6804-12-14-06-NWO	1.38	1.25	0.61	0.72	0.30
6804-12-16-05-NWO	1.50	1.38	0.61	0.84	0.23
6804-12-16-12-NWO	1.50	1.38	0.61	0.84	0.61
6804-12-16-12-NWO-FG	1.50	1.31	0.61	0.84	0.61
6804-12-16-16-NWO	1.50	1.38	0.61	0.84	0.84
6804-12-16-20-NWO	1.50	1.75	0.61	0.84	1.08
6804-12-20-16-NWO	1.88	1.75	0.61	1.08	0.84
6804-14-14-14-NWO	1.38	1.25	0.72	0.72	0.72
6804-16-10-16-NWO	1.00	1.38	0.84	0.48	0.84
6804-16-12-12-NWO	1.25	1.38	0.84	0.61	0.61
6804-16-12-16-NWO	1.25	1.38	0.84	0.61	0.84
6804-16-14-16-NWO	1.38	1.38	0.84	0.72	0.84
6804-16-16-04-NWO	1.50	1.38	0.84	0.84	0.17
6804-16-16-08-NWO	1.50	1.38	0.84	0.84	0.39
6804-16-16-10-NWO	1.88	1.38	0.84	0.84	0.48

6804 STRAIGHT THREAD

RUN TEE (Con't)

SAE J514 070428

MS51530

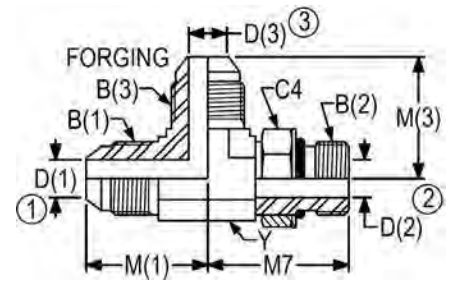
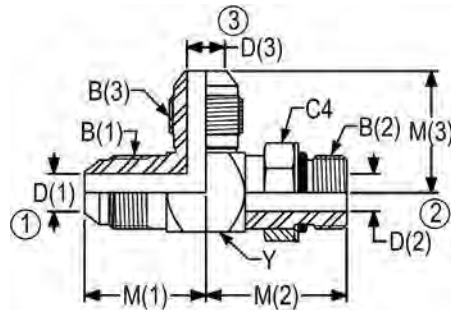

Non forging parts are brazed construction

PART NO	TUBE OD	B (1) UNUNF-2A	B (2) UNUNF-2A	B (3) UNUNF-2A	M (1)	M7	M (3)
6804-16-16-12-NWO	1-3/4	1 5/16-12	1 5/16-12	1 1/16-12	1.81	2.05	1.78
6804-16-16-16-NWO	1-1	1 5/16-12	1 5/16-12	1 5/16-12	1.81	2.05	1.81
6804-16-16-16-NWO-FG	1-1	1 5/16-12	1 5/16-12	1 5/16-12	1.81	2.05	1.81
6804-16-16-20-NWO	1-1 1/4	1 5/16-12	1 5/16-12	1 5/8-12	2.00	2.23	2.06
6804-16-20-10-NWO	1-5/8	1 5/16-12	1 5/8-12	7/8-14	2.00	2.25	1.86
6804-16-20-16-NWO	1-1	1 5/16-12	1 5/8-12	1 5/16-12	2.00	2.25	2.00
6804-16-20-16-NWO-FG	1-1 1/4	1 5/16-12	1 5/8-12	1 5/16-12	2.01	2.25	2.01
6804-16-24-24-NWO	1-1 1/2	1 5/16-12	1 7/8-12	1 7/8-12	2.13	2.39	2.33
6804-20-16-16-NWO	1 1/4-1	1 5/8-12	1 5/16-12	1 5/16-12	2.06	2.23	2.00
6804-20-16-20-NWO	1 1/4-1 1/4	1 5/8-12	1 5/16-12	1 5/8-12	2.06	2.23	2.06
6804-20-20-10-NWO	1 1/4-5/8	1 5/8-12	1 5/8-12	7/8-14	2.06	2.25	1.86
6804-20-20-20-NWO	1 1/4-1 1/4	1 5/8-12	1 5/8-12	1 5/8-12	2.06	2.25	2.06
6804-20-20-20-NWO-FG	1 1/4-1	1 5/8-12	1 5/8-12	1 5/8-12	2.06	2.25	2.06
6804-24-20-24-NWO	1 1/2-1 1/2	1 7/8-12	1 5/8-12	1 7/8-12	2.33	2.38	2.33
6804-24-24-16-NWO	1 1/2-1	1 7/8-12	1 7/8-12	1 5/16-12	2.33	2.39	2.13
6804-24-24-24-NWO	1 1/2-1 1/2	1 7/8-12	1 7/8-12	1 7/8-12	2.33	2.39	2.33
6803-32-32-32-NWO-FG	2-2	2 1/2-12	2 1/2-12	2 1/2-12	3.06	3.06	2.89
6804-32-32-32-NWO	2-2	2 1/2-12	2 1/2-12	2 1/2-12	3.06	2.89	3.06

PART NO	C4	Y	D (1)	D (2)	D (3)
6804-16-16-12-NWO	1.50	1.38	0.84	0.84	0.61
6804-16-16-16-NWO	1.50	1.38	0.84	0.84	0.84
6804-16-16-16-NWO-FG	1.50	1.31	0.84	0.84	0.84
6804-16-16-20-NWO	1.50	1.75	0.84	0.84	1.08
6804-16-20-10-NWO	1.88	1.38	1.08	0.84	0.48
6804-16-20-16-NWO	1.88	1.75	0.84	1.08	0.84
6804-16-20-16-NWO-FG	1.88	1.63	0.84	1.08	0.84
6804-16-24-24-NWO	2.13	2.00	0.84	1.31	1.31
6804-20-16-16-NWO	1.50	1.75	1.08	0.84	0.84
6804-20-16-20-NWO	1.50	1.75	1.08	0.84	1.08
6804-20-20-10-NWO	1.88	1.75	1.08	1.08	0.48
6804-20-20-20-NWO	1.88	1.75	1.08	1.08	1.08
6804-20-20-20-NWO-FG	1.88	1.63	1.08	1.08	1.08
6804-24-20-24-NWO	1.88	2.00	1.31	1.08	1.31
6804-24-24-16-NWO	2.13	2.00	1.31	1.31	0.84
6804-24-24-24-NWO	2.13	2.00	1.31	1.31	1.31
6803-32-32-32-NWO-FG	2.75	2.50	1.78	1.78	1.78
6804-32-32-32-NWO	2.75	2.63	1.78	1.78	1.78

**6805 90 DEGREE STRAIGHT
THREAD/FEMALE PIPE ELBOW**

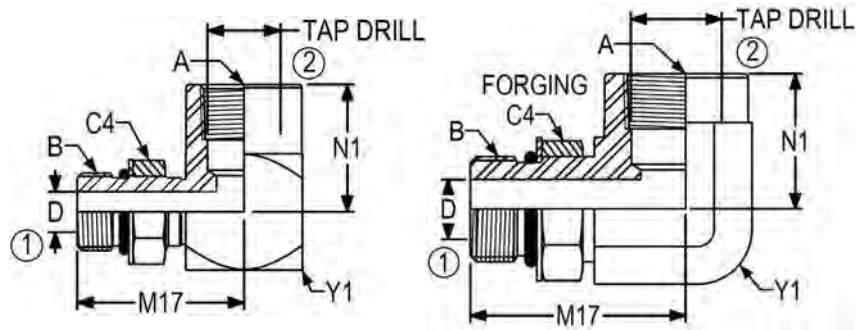

Non forging parts are brazed construction

PART NO	B UN/UNF-2A	A NPTF	M17	N1	C4	Y1	D	TAP DRILL
6805-04-02-NWO	7/16-20	1/8-27	1.09	0.66	0.56	0.63	0.17	0.33
6805-04-04-NWO	7/16-20	1/4-18	1.15	0.88	0.56	0.75	0.17	0.43
6805-04-06-NWO	7/16-20	3/8-18	1.22	1.02	0.56	0.88	0.17	0.57
6805-05-02-NWO	1/2-20	1/8-27	1.16	0.66	0.63	0.63	0.23	0.33
6805-06-02-NWO	9/16-18	1/8-27	1.25	0.66	0.69	0.63	0.30	0.33
6805-06-04-NWO	9/16-18	1/4-18	1.31	0.88	0.69	0.75	0.30	0.43
6805-06-04-NWO-FG	9/16-18	1/4-18	1.31	0.88	0.69	0.75	0.30	0.43
6805-06-06-NWO	9/16-18	3/8-18	1.37	1.02	0.69	0.88	0.30	0.57
6805-08-06-NWO	3/4-16	3/8-18	1.48	1.02	0.88	0.88	0.39	0.57
6805-08-06-NWO-FG	3/4-16	3/8-18	1.47	0.63	0.88	0.88	0.39	0.57
6805-08-08-NWO	3/4-16	1/2-14	1.61	1.23	0.88	1.13	0.39	0.70
6805-10-06-NWO	7/8-14	3/8-18	1.67	1.02	1.00	0.88	0.48	0.57
6805-10-08-NWO	7/8-14	1/2-14	1.79	1.23	1.00	1.13	0.48	0.70
6805-10-12-NWO	7/8-14	3/4-14	1.92	1.36	1.00	1.38	0.48	0.91
6805-12-08-NWO	1 1/16-12	1/2-14	1.94	1.23	1.25	1.13	0.61	0.70
6805-12-12-NWO	1 1/16-12	3/4-14	2.07	1.36	1.25	1.38	0.61	0.91
6805-12-12-NWO-FG	1 1/16-12	3/4-14	2.04	1.36	1.25	1.31	0.61	0.91
6805-14-12-NWO	1 3/16-12	3/4-14	2.07	1.42	1.38	1.38	0.72	0.91
6805-16-04-NWO	1 5/16-12	1/4-18	2.05	1.19	1.50	1.38	0.84	0.43
6805-16-06-NWO	1 5/16-12	3/8-18	2.05	1.26	1.50	1.38	0.84	0.57
6805-16-08-NWO	1 5/16-12	1/2-14	2.05	1.36	1.50	1.38	0.84	0.70
6805-16-12-NWO	1 5/16-12	3/4-14	2.05	1.36	1.50	1.38	0.84	0.91
6805-16-16-NWO	1 5/16-12	1-11 1/2	2.17	1.62	1.50	1.63	0.84	1.14
6805-20-12-NWO	1 5/8-12	3/4-14	2.25	1.55	1.88	1.75	1.08	0.91
6805-20-16-NWO	1 5/8-12	1-11 1/2	2.25	1.68	1.88	1.75	1.08	1.14
6805-20-20-NWO	1 5/8-12	1 1/4-11 1/2	2.38	1.70	1.88	2.00	1.08	1.48
6805-24-24-NWO	1 7/8-12	1 1/2-11 1/2	2.58	2.08	2.13	2.38	1.31	1.72
6805-32-32-NWO	2 1/2-12	2-11 1/2	3.02	2.39	2.75	2.88	1.78	2.19

**6806 90 DEGREE STRAIGHT THREAD/MALE
PIPE ELBOW**

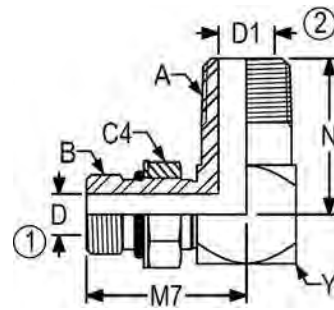

PART NO	B UN/UNF-2A	A NPTF	M7	N	C4	Y	D	D1
6806-02-04-NWO	5/16-24	1/4-18	1.03	1.09	0.56	0.63	0.06	0.28
6806-04-02-NWO	7/16-20	1/8-27	1.03	0.78	0.56	0.50	0.17	0.19
6806-04-04-NWO	7/16-20	1/4-18	1.09	1.09	0.56	0.63	0.17	0.28
6806-04-06-NWO	7/16-20	3/8-18	1.19	1.22	0.56	0.81	0.17	0.41
6806-05-02-NWO	1/2-20	1/8-27	1.13	0.81	0.63	0.56	0.23	0.19
6806-05-06-NWO	1/2-20	3/8-18	1.25	1.22	1.63	0.81	0.23	0.41
6806-06-04-NWO	9/16-18	1/4-18	1.25	1.09	0.69	0.63	0.30	0.28
6806-06-06-NWO	9/16-18	3/8-18	1.34	1.22	0.69	0.81	0.30	0.41
6806-06-08-NWO	9/16-18	1/2-14	1.40	1.47	0.69	0.94	0.30	0.53
6806-08-06-NWO	3/4-16	3/8-18	1.45	1.22	0.88	0.81	0.39	0.41
6806-08-08-NWO	3/4-16	1/2-14	1.51	1.47	0.88	0.94	0.39	0.53
6806-10-08-NWO	7/8-14	1/2-14	1.70	1.47	1.00	0.94	0.48	0.53
6806-12-06-NWO	1 1/16-12	3/8-18	1.94	1.38	1.25	1.13	0.61	0.41
6806-12-08-NWO	1 1/16-12	1/2-14	1.94	1.56	1.25	1.13	0.61	0.53
6806-12-12-NWO	1 1/16-12	3/4-14	1.94	1.59	1.25	1.13	0.61	0.72
6806-12-16-NWO	1 1/16-12	1-11 1/2	2.07	1.97	1.25	1.38	0.61	0.94
6806-14-12-NWO	1 3/16-12	3/4-14	2.00	1.66	1.38	1.25	0.72	0.72
6806-16-12-NWO	1 5/16-12	3/4-14	2.05	1.72	1.50	1.38	0.84	0.72
6806-16-16-NWO	1 5/16-12	1-11 1/2	2.05	1.97	1.50	1.38	0.84	0.94
6806-20-16-NWO	1 5/8-12	1-11 1/2	2.25	2.16	1.88	1.75	1.08	0.94
6806-20-20-NWO	1 5/8-12	1 1/4-11 1/2	2.25	2.38	1.88	1.75	1.08	1.25
6806-20-24-NWO	1 5/8-12	1 1/2-11 1/2	2.38	2.64	1.88	2.00	1.08	1.50
6806-24-24-NWO	1 7/8-12	1 1/2-11 1/2	2.39	2.64	2.13	2.00	1.31	1.50

**6807 90 DEGREE STRAIGHT THREAD UNION
ELBOW**

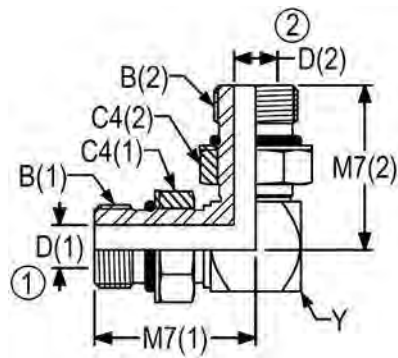

PART NO	B (1) UN/UNF-2A	B (2) UN/UNF-2A	M7 (1)	M7 (2)	C4 (1)	C4 (2)	Y	D (1)	D (2)
6807-04-04-NWO	7/16-20	7/16-20	1.03	1.03	0.56	0.56	0.50	0.17	0.17
6807-06-04-NWO	9/16-18	7/16-20	1.25	1.09	0.69	0.56	0.63	0.30	0.17
6807-06-06-NWO	9/16-18	9/16-18	1.25	1.25	0.69	0.69	0.63	0.30	0.30
6807-08-06-NWO	3/4-16	9/16-18	1.45	1.34	0.88	0.69	0.81	0.39	0.30
6807-08-08-NWO	3/4-16	3/4-16	1.45	1.45	0.88	0.88	0.81	0.39	0.39
6807-10-08-NWO	7/8-14	3/4-16	1.70	1.51	1.00	0.88	0.94	0.48	0.39
6807-10-10-NWO	7/8-14	7/8-14	1.70	1.70	1.00	1.00	0.94	0.48	0.48
6807-12-12-NWO	1 1/16-12	1 1/16-12	1.94	1.94	1.25	1.25	1.13	0.61	0.61
6807-16-16-NWO	1 5/16-12	1 5/16-12	2.05	2.05	1.50	1.50	1.38	0.84	0.84
6807-20-20-NWO	1 5/8-12	1 5/8-12	2.25	2.25	1.88	1.88	1.75	1.08	1.08
6807-24-24-NWO	1 7/8-12	1 7/8-12	2.39	2.39	2.13	2.13	2.00	1.31	1.31

**6808 45 DEGREE STRAIGHT THREAD UNION
ELBOW**

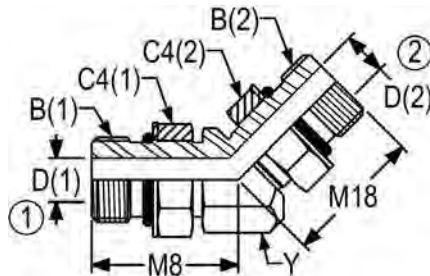

PART NO	B (1) UN/UNF-2A	B (2) UN/UNF-2A	M8	M18	C4 (1)	C4 (2)	Y	D (1)	D (2)
6808-04-04-NWO	7/16-20	7/16-20	1.05	0.91	0.56	0.56	0.50	0.17	0.17
6808-06-06-NWO	9/16-18	9/16-18	1.14	1.07	0.69	0.69	0.63	0.30	0.30
6808-08-06-NWO	3/4-16	9/16-18	1.30	1.11	0.88	0.69	0.81	0.39	0.30
6808-08-08-NWO	3/4-16	3/4-16	1.30	1.23	0.88	0.88	0.81	0.39	0.39
6808-16-12-NWO	1 5/16-12	1 1/16-12	1.86	1.74	1.50	1.25	1.38	0.84	0.61
6808-16-16-NWO	1 5/16-12	1 5/16-12	1.86	1.70	1.50	1.50	1.38	0.84	0.84
6802-20-16-NWO	1 5/8-12	1 5/16-12	1.91	1.78	1.88	1.50	1.75	0.84	0.84
6808-20-20-NWO	1 5/8-12	1 5/8-12	1.91	1.78	1.88	1.88	1.75	1.08	1.08
6808-24-16-NWO	1 7/8-12	1 5/16-12	1.91	1.88	2.13	1.50	2.00	0.84	0.84
6808-24-24-NWO	1 7/8-12	1 7/8-12	1.91	1.84	2.13	2.13	2.00	1.31	1.31

**6809 90 DEGREE STRAIGHT
THREAD/SWIVEL ELBOW**

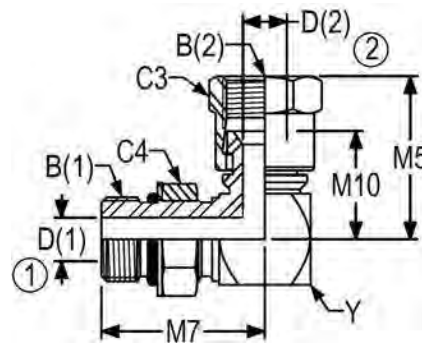

PART NO	TUBE OD	B (1) UN/UNF-2A	B (2) UN/UNF-2B	M7	M5	M10	C3	C4	Y	D (1)	D (2)
6809-04-04-NWO	1/4	7/16-20	7/16-20	1.03	1.00	0.66	0.56	0.56	0.50	0.17	0.17
6809-06-04-NWO	1/4	9/16-18	7/16-20	1.25	1.06	0.72	0.56	0.69	0.63	0.30	0.17
6809-06-06-NWO	3/8	9/16-18	9/16-18	1.25	1.25	0.88	0.69	0.69	0.63	0.30	0.30
6809-08-06-NWO	3/8	3/4-16	9/16-18	1.45	1.34	0.97	0.69	0.88	0.81	0.39	0.30
6809-08-08-NWO	1/2	3/4-16	3/4-16	1.45	1.38	0.96	0.88	0.88	0.81	0.39	0.39
6809-08-12-NWO	3/4	3/4-16	1 1/16-12	1.61	1.75	1.19	1.25	0.88	1.13	0.39	0.61
6809-10-08-NWO	1/2	7/8-14	3/4-16	1.70	1.44	1.02	0.88	1.00	0.94	0.48	0.39
6809-10-10-NWO	5/8	7/8-14	7/8-14	1.70	1.62	1.12	1.00	1.00	0.94	0.48	0.48
6808-12-10-NWO	5/8	1 1/16-12	7/8-14	1.94	1.71	1.21	1.00	1.25	1.13	0.61	0.48
6809-12-12-NWO	3/4	1 1/16-12	1 1/16-12	1.94	1.75	1.19	1.25	1.25	1.13	0.61	0.61
6809-16-16-NWO	1	1 5/16-12	1 5/16-12	2.05	2.00	1.41	1.50	1.50	1.38	0.84	0.84
6809-20-20-NWO	1 1/4	1 5/8-12	1 5/8-12	2.25	2.31	1.68	2.00	1.88	1.75	1.08	1.08
6809-24-24-NWO	1 1/2	1 7/8-12	1 7/8-12	2.39	2.59	1.86	2.25	2.25	2.00	1.31	1.31

**6810 45 DEGREE STRAIGHT
THREAD/SWIVEL ELBOW**

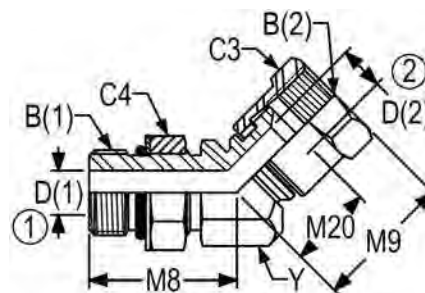

PART NO	TUBE OD	B (1) UN/UNF-2A	B (2) UN/UNF-2B	M8	M19	M20	C3	C4	Y	D (1)	D (2)
6810-04-04-NWO	1/4	7/16-20	7/16-20	1.05	0.88	0.53	0.56	0.56	0.50	0.17	0.17
6810-06-06-NWO	3/8	9/16-18	9/16-18	1.14	1.07	0.69	0.69	0.69	0.63	0.30	0.30
6810-08-08-NWO	1/2	3/4-16	3/4-16	1.30	1.16	0.74	0.88	0.88	0.81	0.39	0.39
6810-10-10-NWO	5/8	7/8-14	7/8-14	1.52	1.32	0.82	1.00	1.00	0.94	0.48	0.48
6810-12-12-NWO	3/4	1 1/16-12	1 1/16-12	1.73	1.38	0.81	1.25	1.25	1.13	0.61	0.61
6810-16-16-NWO	1	1 5/16-12	1 5/16-12	1.86	1.68	1.09	1.50	1.50	1.38	0.84	0.84

**6811 45 DEGREE STRAIGHT
THREAD/ FEMALE PIPE ELBOW**

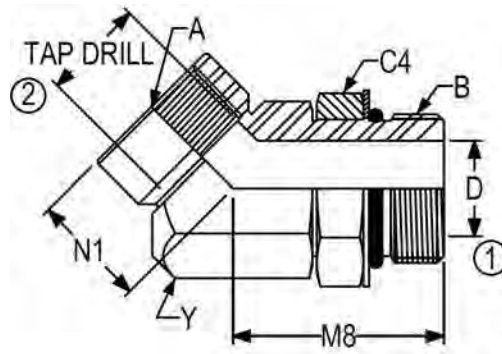

PART NO	B UN/UNF-2A	A NPTF	N1	M8	C4	Y	D	TAP DRILL
6811-16-04-NWO	1 5/16-12	1/4-18	0.95	1.86	1.50	1.38	0.61	0.43
6811-16-06-NWO	1 5/16-12	3/8-18	1.03	1.86	1.50	1.38	0.61	0.57
6811-16-08-NWO	1 5/16-12	1/2-14	1.03	1.86	1.50	1.38	0.61	0.70
6811-16-12-NWO	1 5/16-12	3/4-14	1.02	1.86	1.50	1.38	0.84	0.91
6811-16-16-NWO	1 5/16-12	1-11 1/2	1.12	1.92	1.50	1.63	0.84	1.14
6811-20-08-NWO	1 5/8-12	1/2-14	1.07	1.91	1.88	1.75	0.84	0.70
6811-20-12-NWO	1 5/8-12	3/4-14	1.07	1.91	1.88	1.75	0.84	0.91
6811-20-16-NWO	1 5/8-12	1-11 1/2	1.07	1.91	1.88	1.75	0.84	1.14
6811-20-20-NWO	1 5/8-12	1 1/4-11 1/2	1.63	1.92	1.88	1.63	1.08	1.48

O-Rings For SAE J-1926/2/3 Stud Ends

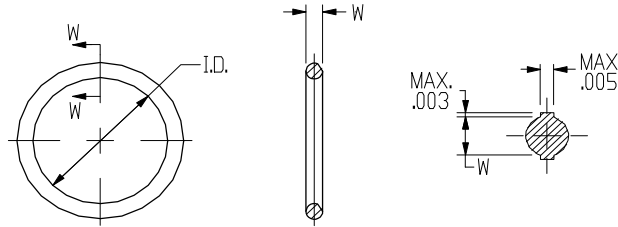

TUBE SIZE	STANDARD A-W PART #	ITEM #	OPTIONAL COMPOUND ITEM #			SAE AS568A REF. #	I.D.	W
	CH (BUNA-N) 4000		HK (VITON) 4001-	CH (HI-TEMP) ⁽¹⁾ 4002-	CA (EPDM) 4006-			
-02	4000-02	0001	*	*	*	902	.239 ±.005	.064 ±.003
-03	4000-03	0002	0002	*	*	903	.301 ±.005	.064 ±.003
-04	4000-04	0003	0003	0200	*	904	.351 ±.005	.072 ±.003
-05	4000-05	0004	0004	0300	*	905	.414 ±.005	.072 ±.003
-06	4000-06	0005	0005	0400	*	906	.468 ±.005	.078 ±.003
-08	4000-08	0006	0006	0500	*	908	.644 ±.009	.087 ±.003
-10	4000-10	0007	0007	0600	*	910	.755 ±.009	.097 ±.003
-12	4000-12	0008	0008	0700	*	912	.924 ±.009	.116 ±.004
-14	4000-14	0009	0009	0800	*	914	1.048 ±.010	.116 ±.004
-16	4000-16	0010	0010	0900	*	916	1.171 ±.010	.116 ±.004
-20	4000-20	0011	0011	1000	*	920	1.475 ±.014	.118 ±.004
-24	4000-24	0012	0012	1100	*	924	1.720 ±.014	.118 ±.004
-32	4000-32	0013	0013	*	*	932	2.337 ±.018	.118 ±.004

SAE Type CH was SAE Type 1 Type CA was SAE Type 2 and Type HK was SAE Type 3.

Specification	SAE/ASTM Type CH	SAE/ASTM Type CA	SAE/ASTM Type HK
Usage	Nitrile Elastomer, 90 Durometer Hardness, for petroleum based fluids	EPDM Elastomer, 80 Durometer Hardness, for water based hydraulic or nonpetroleum based fluids	Fluorocarbon Elastomer, 90 Durometer Hardness, for petroleum or nonpetroleum based fluids
General Service	High pressure applications of pneumatics, water based hydraulic fluids, lubricating oils, hydraulic oils, and gasoline	High pressure applications of nonflammable hydraulic fluids of phosphate ester base type	High pressure, high temperature applications of pneumatic, water based hydraulic fluids, lubricating oils, hydraulic oils, and fuels
Temperature	-35°C to 125°C (-30°F to 250°F)	-40°C to 125°C (-40°F to 250°F)	-15°C to 275°C (5°F to 525°F)
Shore Hardness	90 pts ±5 pts	80 pts ±5 pts	90 pts ±5 pts
Elongation	100% min	150% min	100% min
Tensile	10 MPa min	10 MPa min	10 MPa min
Compound	Nitrile (Buna-N) to ASTM D 2000 or SAE J200 M4CH910B14E015E35Z1 Z1 = TR 10 temperature -21° C or lower. Alternate Low Temperature Product Test, 5 hours at -30° C, rings compressed 25% of ID, no cracks.	EPDM to ASTM D 2000 or SAE J200 M7CA810A25B35F17	M7HK910A1-11B38EF31E088Z1 Z1 = TR 10 temperature -15°C or lower (similar to MIL-R 83248 Type 1, Class 2)
Lubrication	When assembling Type CH O-Rings with O-Ring style fittings, the O-Ring shall be coated with the fluid used or petrolatum before assembly to ease installation.	When assembling Type CA O-Rings with O-Ring style fittings, lubricate the O-Ring with the fluid used in the system. Do not use a petroleum-based lubricant.	When assembling Type HK O-Rings with O-Ring style fittings, the O-Ring shall be coated with the fluid used or petrolatum before assembly to ease installation.

1. Type CH(HI-TEMP) Air-Way part #4002, 90 Durometer Nitrile Compound, temperature range -32°C to 135°C(-25°F to 275°F). Approved compounds National O-Ring Compound C67-90, Parker Seal Groove Compound N1059-90.

Features, Braze Fittings For Tubing

The fittings described in this section provide a variety of braze on end connections for tube assembly/fabrication requirements. Fitting styles are available with male 37 degree tube and bulkhead ends, female 37 degree swivel ends, male or female NPTF pipe ends, female pipe swivels, SAE J518 four-bolt flanges and tube to tube junction blocks.

Standard braze joint designs provide a slip fit to nominal O.D. inch size tubing and are intended for silver brazing. Press fit counterbores and other special designs are available on request.

All 37 degree fitting styles are also available with the optional **FLARE-O**[®] tube end design.

Performance

Where applicable, fittings are designed and qualified to the requirements of SAE J514. Four bolt flange ends conform to SAE J518.

The rated working pressures for braze fittings are based on the standard pressure rating of the separable fitting end. For proper performance, the design of any hydraulic system should take into consideration the rated working pressures for each of the components of the system, including standard ratings for hose and tubing components. For brazed tube assemblies, these factors include the tubing material specifications, fabrication techniques and braze processes.

Construction

Unless otherwise specified, fittings are machined from cold drawn carbon steel barstock and forgings. Standard plating is electrodeposited zinc with a clear trivalent chromate conversion coating in accordance with ASTM B633 (Type V SC2). The minimum salt spray resistance is 240 hours to red corrosion when tested in accordance with ASTM B117.

Threads

Straight Threads: Internal and external straight threads conform to the Unified National Class 2A and Class 2B Series respectively, with modified minor diameters where specified. Maximum diameters of plated external threads may conform to Class 3A maximum diameters after plating.

NPTF Threads: Male and female pipe threads conform to the Dryseal American Standard Taper Pipe Thread (SAE J476a, NPTF) Series which will provide pressure tight joints without the use of a lubricant or sealer. Use of these fittings with non-dryseal NPT pipe or hose ends is not recommended for high-pressure applications.

Note: Where not functionally objectionable, use of a compatible lubricant/sealant is recommended for either NPT or NPTF threads to minimize the possibility of galling in assembly.

NPSM Swivels: Female threads for adapter union swivel nuts conform to the American Standard Straight Pipe Thread (NPSM) Series. These threads mate with either NPT or NPTF Series male threads to provide a mechanical connection between the adapter and mating male end. Sealing is provided by metal to metal contact between the machined 30 degree female seat on the NPT/NPTF male end and the nose of the swivel end. The NPSM swivel threads are not a sealing member.

Caution: *For proper sealing, ensure that the mating male end has been machined with the proper 30 degree female seat.*

Assembly Information

For silver brazing and fitting assembly instructions, refer to the Technical Data Section for the appropriate fitting end. Also, refer to the Technical Data Section for recommendations regarding tubing pressure ratings, tube flares and hose/tube routing information. Please note: Tubing for single flare tube ends should be either seamless or welded and drawn, fully annealed tubing per SAE J524 or J525. For double flaring, tubing per SAE J356, J524, J525 or J526 may be used.

For proper sealing with 37 degree flared fittings, flares for tubing should conform to the requirements of SAE J533. For heavy wall tubing, the optional tube preparation and single flare configuration specified in SAE J533 is also recommended. This optional configuration provides extended sealing surface contact area versus conventional flares.

In the design and fabrication of tubing or hose runs for any hydraulic system, precautions should be taken to allow for sufficient adjustment of the hose or tubing so that proper alignment can be attained at the fitting connections. Improper fit-up or misalignment should be corrected before final connections are made. Location of fitting connections should be planned to maximize accessibility. Whenever possible, use a torque wrench to tighten connections to the recommended torque.

Ordering Information

Size of fittings is indicated by dash number relating to sixteenths of an inch for the nominal O.D. of the tube size used. Example: 1/2 inch tube = 8/16 or (-8) size.

Order standard fittings from appropriate chart indicating required dash numbers. For example, 500-8-8 is a 90 degree braze elbow with 1/2" nominal braze counterbore and 1/2" male tube end (3/4-16 thread). Jump size 500-10-8 is a 90 degree braze elbow with 5/8" nominal braze counterbore and 1/2" male tube end (3/4-16 thread).

Pictorial views for each fitting style indicate the correct numbering sequence for fitting ends.

If information is needed for jump sizes not shown, please contact customer service for engineering assistance.

Table JB1. Pressure Ratings for 37 Deg. Flared Tube Ends, Bulkheads and 37 Deg. Female Swivels

Nominal Tube Size		Thread Size	Working Pressures			
Nom SAE Dash Size	Nom Inch Tube O.D.	SAE J514 Flared Tube Ends, Unions, Bulkheads and Swivels (Notes 1&2)	37 Deg. Flared Tube Ends, Unions and Bulkheads		37 Deg. Female Swivels	
			MPa	psi	MPa	psi
-02	1/8	5/16-24 UNF	34.5	5,000	34.5	5,000
-03	3/16	3/8-24 UNF	34.5	5,000	34.5	5,000
-04	1/4	7/16-20 UNF	34.5	5,000	31	4,500
-05	5/16	1/2-20 UNF	34.5	5,000	27.5	4,000
-06	3/8	9/16-18 UNF	34.5	5,000	27.5	4,000
-08	1/2	3/4-16 UNF	31	4,500	27.5	4,000
-10	5/8	7/8-14 UNF	24	3,500	21	3,000
-12	3/4	1-1/16-12 UN	24	3,500	21	3,000
-14	7/8	1-3/16-12 UN	21	3,000	17	2,500
-16	1	1-5/16-12 UN	21	3,000	17	2,500
-20	1 1/4	1-5/8-12 UN	17	2,500	14	2,000
-24	1 1/2	1-7/8-12 UN	14	2,000	10.5	1,500
-32	2	2-1/2-12 UN	10.5	1,500	8	1,125

1) Threads per SAE J475 Class 2A ext. Class 2B int. (Ref. ISO-263/ISO-R725)

2) Unified class 2B threads apply to swivel nuts and with minor diameter modified to class 3B limits for locknuts

Table JB2. Pressure Ratings for Fittings With NPTF Pipe Threads and NPSM Female Swivels

Nominal Pipe Size		Thread Size		Working Pressures			
Nom SAE Dash Size	Nom Inch Pipe O.D.	Dryseal Pipe Thread (NPTF ¹) Male and Female	Straight Pipe Thread (NPSM ²) Female Swivels	Fittings With NPTF Pipe Threads		NPSM Female Swivels	
				MPa	psi	MPa	psi
-02	1/8	1/8-27	1/8-27	34.5	5,000	34.5	5,000
-04	1/4	1/4-18	1/4-18	27.5	4,000	34.5	5,000
-06	3/8	3/8-18	3/8-18	21	3,000	27.6	4,000
-08	1/2	1/2-14	1/2-14	21	3,000	24.1	3,500
-12	3/4	3/4-14	3/4-14	17	2,500	15.5	2,250
-16	1	1-11-1/2	1-11-1/2	14	2,000	13.8	2,000
-20	1 1/4	1-1/4-11-1/2	1-1/4-11-1/2	8	1,150	11.2	1,625
-24	1 1/2	1-1/2-11-1/2	1-1/2-11-1/2	7	1,000	8.6	1,250
-32	2	2-11-1/2	2-11-1/2	7	1,000	7.8	1,125

1) Dryseal American Standard Taper Pipe Thread

2) American Standard Straight Pipe Thread for Mechanical Joints

Table JB3. Pressure Ratings for Code 61 Four-Bolt Split Flange Ends















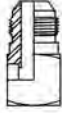
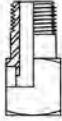
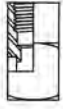
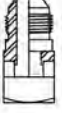
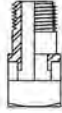
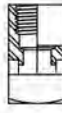

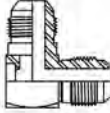
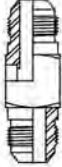
Nominal Flange Size		Bolt Dimensions			Working Pressures @ Recommended Torque (Note: See Below)			
Nom SAE Dash Size	Nom Inch Pipe O.D.	Thread	Length		Maximum Recommended Working Pressure		Recommended Torque Range	
			mm	inch	MPa	psi	Nm	lb-in
-08	1/2	5/16-18	32	1-1/4	34.5	5,000	20-25	175-225
-12	3/4	3/8-16	32	1-1/4	34.5	5,000	28-40	250-350
-16	1	3/8-16	32	1-1/4	34.5	5,000	37-48	325-425
-20	1 1/4	7/16-14	38	1-1/2	27.6	4,000	48-62	425-550
-24	1 1/2	1/2-13	38	1-1/2	20.7	3,000	62-79	550-700
-32	2	1/2-13	38	1-1/2	20.7	3,000	73-90	650-800

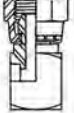
Table JB4. Pressure Ratings for Code 62 Four-Bolt Split Flange Ends

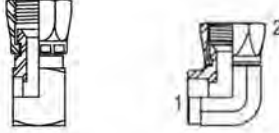
Nominal Flange Size		Bolt Dimensions			Working Pressures @ Recommended Torque (Note: See Below)			
Nom SAE Dash Size	Nom Inch Pipe O.D.	Thread	Length		Maximum Recommended Working Pressure		Recommended Torque Range	
			mm	inch	MPa	psi	Nm	lb-in
-08	1/2	5/16-18	32	1-1/4	41.4	6,000	20-25	175-225
-12	3/4	3/8-16	38	1-1/2	41.4	6,000	34-45	300-400
-16	1	7/16-14	44	1-3/4	41.4	6,000	56-68	500-600
-20	1 1/4	1/2-13	44	1-3/4	41.4	6,000	85-102	750-900
-24	1 1/2	5/8-11	57	2-1/4	41.4	6,000	158-181	1400-1600
-32	2	3/4-10	70	2-3/4	41.4	6,000	271-294	2400-2600

Note: SAE J518, Code 61 and Code 62 Four-Bolt Split Flange connections are non-threaded port ends which utilize O-Rings for sealing. They are assembled to ports with split flange clamp halves and clamping pressure is provided by bolts or socket head cap screws of SAE Grade 5 material or better as specified in SAE J429.

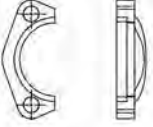
Rated design factor for these connections is dependent on the selected grade for the clamp bolts. Flanged head ends are incorporated into fittings having suitable means for attachment to tubes, pipes or hoses to provide connection ends.

 <p>0403- (1)Bore (2)Male Tube</p>	 <p>403-L- (1)Bore (2)Bulkhead</p>	 <p>404- (1)Bore (2)Male Pipe</p>	 <p>405- (1)Bore (2)Female Pipe</p>	 <p>500- (1)Bore (2)Male Tube</p>	 <p>501- (1)Bore (2)Male Pipe</p>	 <p>502- (1)Bore (2)Female Pipe</p>
 <p>600- (1&2)Bore (3)Male Tube</p>	 <p>601- (1&2)Bore (3)Male Pipe</p>	 <p>602- (1&2)Bore (3)Female Tube</p>	 <p>603- (1,2,&3)Bore</p>	 <p>701- (1)Bore (2&3)Male Tube</p>	 <p>702- (1)Bore (2&3)Male Tube</p>	 <p>800- (1)Bore (2)Female Pipe Swivel</p>
 <p>801- (1)Bore (2)Female Pipe Swivel</p>	 <p>900- (1)Bore (2)37° Female Swivel</p>	 <p>901- (1)Bore (2)37° Female Swivel</p>		 <p>902- (1)Bore (2&3)37° Female Swivel</p>	 <p>3300-61- (1)Bore (2)Code 61 Flange</p>	 <p>3300-62- (1)Bore (2)Code 62 Flange</p>
 <p>31205-61- Code 61 Split Flange Clamp See flange adapters</p>	 <p>31205-62- Code 62 Split Flange Clamp See flange adapters</p>					

0403 BRAZE TUBE UNION

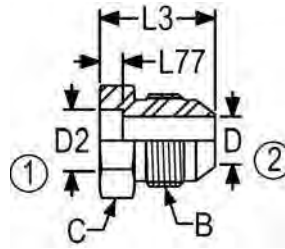

PART NO	TUBE OD	B UN/UNF-2A	L3	L7	C	D	D2
0403-04-04 PF UNPL	1/4-1/4	7/16-20	0.80	0.125	0.50	0.17	0.247
0403-04-04 UNPL	1/4-1/4	7/16-20	0.80	0.125	0.50	0.17	0.254
0403-05-05 UNPL	5/16-5/16	1/2-20	0.80	0.133	0.56	0.23	0.316
0403-06-06 PF UNPL	3/8-3/8	9/16-18	0.84	0.140	0.63	0.30	0.372
0403-06-06 UNPL	3/8-3/8	9/16-18	0.84	0.140	0.63	0.30	0.379
0403-06-08 UNPL	3/8-1/2	3/4-16	0.94	0.140	0.81	0.30	0.379
0403-08-08 PF UNPL	1/2-1/2	3/4-16	0.94	0.188	0.81	0.39	0.497
0403-08-08 UNPL	1/2-1/2	3/4-16	0.94	0.188	0.81	0.39	0.504
0403-08-12 UNPL	1/2-3/4	1 1/16-12	1.24	0.188	1.13	0.39	0.504
0403-10-08 UNPL	5/8-1/2	3/4-16	0.94	0.188	0.81	0.39	0.631
0403-10-10 PF UNPL	5/8-5/8	7/8-14	1.10	0.218	0.94	0.48	0.622
0403-10-10 UNPL	5/8-5/8	7/8-14	1.10	0.218	0.94	0.48	0.631
0403-10-12 UNPL	5/8-3/4	1 1/16-12	1.28	0.218	1.13	0.48	0.631
0403-12-08 UNPL	3/4-1/2	3/4-16	0.98	0.232	0.94	0.39	0.756
0403-12-10 UNPL	3/4-5/8	7/8-14	1.10	0.232	0.94	0.48	0.756
0403-12-12 PF UNPL	3/4-3/4	1 1/16-12	1.28	0.232	1.13	0.61	0.747
0403-12-12 UNPL	3/4-3/4	1 1/16-12	1.28	0.232	1.13	0.61	0.756
0403-14-12 UNPL	7/8-3/4	1 1/16-12	1.28	0.241	1.13	0.61	0.881
0403-14-14 UNPL	7/8-7/8	1 3/16-12	1.31	0.241	1.25	0.72	0.881
0403-16-10 UNPL	1-5/8	7/8-14	1.28	0.312	1.38	0.48	1.007
0403-16-12 PF UNPL	1-3/4	1 1/16-12	1.28	0.250	1.25	0.61	0.997
0403-16-12 UNPL	1-3/4	1 1/16-12	1.28	0.250	1.25	0.61	1.006
0403-16-16 PF UNPL	1-1	1 5/16-12	1.33	0.250	1.38	0.84	0.997
0403-16-16 UNPL	1-1	1 5/16-12	1.33	0.250	1.38	0.84	1.006
0403-16-20 UNPL	1-1 1/4	1 5/8-12	1.45	0.250	1.69	0.84	1.006
0403-20-16 UNPL	1 1/4-1	1 5/16-12	1.33	0.250	1.38	0.84	1.256
0403-20-20 PF UNPL	1 1/4-1 1/4	1 5/8-12	1.45	0.312	1.69	1.08	1.247
0403-20-20 UNPL	1 1/4-1 1/4	1 5/8-12	1.45	0.312	1.69	1.08	1.256
0403-20-24 UNPL	1 1/4-1 1/2	1 7/8-12	1.65	0.312	2.00	1.08	1.256
0403-24-20 UNPL	1 1/2-1 1/4	1 5/8-12	1.45	0.343	1.69	1.08	1.506
0403-24-24 PF UNPL	1 1/2-1 1/2	1 7/8-12	1.65	0.343	2.00	1.31	1.497
0403-24-24 UNPL	1 1/2-1 1/2	1 7/8-12	1.65	0.343	2.00	1.31	1.506
0403-32-32 UNPL	2-2	2 1/2-12	2.05	0.343	2.63	1.78	2.006

*PF=PRESS FIT

403-L BRAZE BULKHEAD UNION

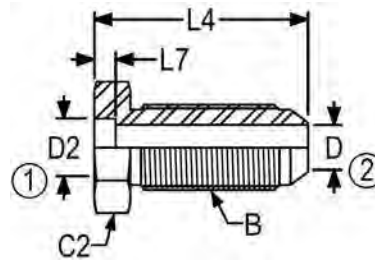

PART NO	TUBE OD	B UN/UNF-2A	L4	L7	C2	D	D2
403-L-08-08 UNPL	1/2-1/2	3/4-16	1.88	0.188	1.00	0.39	0.504
403-L-10-10 UNPL	5/8-5/8	7/8-14	2.06	0.218	1.13	0.48	0.631
403-L-12-12 UNPL	3/4-3/4	1 1/16-12	2.17	0.232	1.38	0.61	0.756
403-L-16-16 UNPL	1-1	1 5/16-12	2.33	0.250	1.63	0.84	1.006

404 MALE PIPE UNION

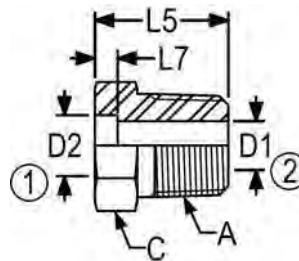

PART NO	TUBE OD	A NPTF	L5	L7	C	D1	D2
404-06-04 UNPL	3/8	1/4-18	0.81	0.140	0.63	0.28	0.379
404-06-06 UNPL	3/8	3/8-18	0.85	0.140	0.81	0.28	0.379
404-08-06 UNPL	1/2	3/8-18	0.85	0.188	0.81	0.41	0.504
404-08-08 UNPL	1/2	1/2-14	1.10	0.188	0.94	0.41	0.504
404-10-08 UNPL	5/8	1/2-14	1.10	0.218	0.94	0.53	0.631
404-12-08 UNPL	3/4	1/2-14	1.10	0.232	0.94	0.53	0.756
404-12-12 UNPL	3/4	3/4-14	1.10	0.232	1.13	0.61	0.756
404-16-08 UNPL	1	1/2-14	1.12	0.250	1.25	0.53	1.006
404-16-12 UNPL	1	3/4-14	1.25	0.250	1.25	0.72	1.006
404-16-16 UNPL	1	1-11 1/2	1.31	0.250	1.38	0.84	1.006
404-20-16 UNPL	1 1/4	1-11 1/2	1.31	0.250	1.50	0.94	1.256
404-20-20 UNPL	1 1/4	1 1/4-11 1/2	1.41	0.312	1.69	1.08	1.256
404-24-24 UNPL	1 1/2	1 1/2-11 1/2	1.50	0.343	2.00	1.31	1.506
404-32-32 UNPL	2	2-11 1/2	1.78	0.343	2.63	1.78	2.006

405 BRAZE FEMALE PIPE UNION

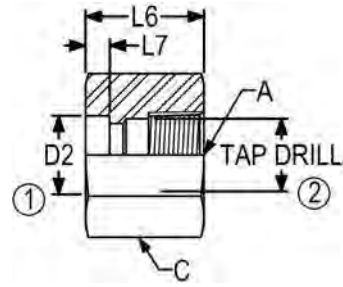

PART NO	TUBE OD	A NPTF	L6	L7	C	TAP DRILL	D2
405-06-04	3/8	1/4-18	0.75	0.140	0.75	0.43	0.379
405-12-08	3/4	1/2-14	1.06	0.232	1.13	0.70	0.756
405-12-12	3/4	3/4-14	1.14	0.232	1.38	0.91	0.756
405-20-20	1 1/4	1 1/4-11 1/2	1.52	0.312	2.00	1.48	1.256
405-24-24	1 1/2	1 1/2-11 1/2	1.38	0.343	2.13	1.72	1.506

500 BRAZE 90 DEGREE TUBE ELBOW

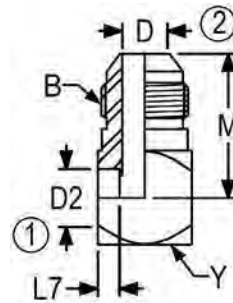

PART NO	TUBE OD	B UN/UNF-2A	M	L7	Y	D2	D
500-02-2 UNPL	1/8-1/8	5/16-24	0.77	0.093	0.44	0.129	0.06
500-04-04 UNPL	1/4-1/4	7/16-20	0.89	0.125	0.50	0.254	0.17
500-05-05 UNPL	5/16-5/16	1/2-20	0.95	0.133	0.56	0.316	0.23
500-06-05 PF UNPL	3/8-5/16	1/2-20	0.95	0.140	0.56	0.372	0.23
500-06-05 UNPL	3/8-5/16	1/2-20	0.95	0.140	0.56	0.379	0.23
500-06-06 PF UNPL	3/8-3/8	9/16-18	1.06	0.140	0.63	0.372	0.30
500-06-06 UNPL	3/8-3/8	9/16-18	1.06	0.140	0.63	0.379	0.30
500-08-08 PF UNPL	1/2-1/2	3/4-16	1.25	0.188	0.81	0.497	0.39
500-08-08 UNPL	1/2-1/2	3/4-16	1.25	0.188	0.81	0.504	0.39
500-08-10 UNPL	1/2-5/8	7/8-14	1.45	0.200	0.94	0.504	0.48
500-10-08 UNPL	5/8-1/2	3/4-16	1.31	0.218	0.94	0.631	0.39
500-10-10 UNPL	5/8-5/8	7/8-14	1.45	0.203	0.94	0.631	0.48
500-12-08 UNPL	3/4-1/2	3/4-16	1.31	0.232	0.94	0.756	0.39
500-12-12 PF UNPL	3/4-3/4	1 1/16-12	1.66	0.232	1.13	0.747	0.61
500-12-12 UNPL	3/4-3/4	1 1/16-12	1.66	0.232	1.13	0.756	0.61
500-12-16 UNPL	3/4-1	1 5/16-12	1.81	0.232	1.38	0.756	0.84
500-14-14 UNPL	7/8-7/8	1 3/16-12	1.80	0.232	1.25	0.881	0.72
500-16-12 UNPL	1-3/4	1 1/16-12	1.66	0.232	1.13	1.006	0.61
500-16-16 UNPL	1-1	1 5/16-12	1.81	0.250	1.38	1.006	0.84
500-20-16 UNPL	1 1/4-1	1 5/16-12	1.88	0.312	1.50	1.256	0.84
500-20-20 UNPL	1 1/4-1 1/4	1 5/8-12	2.06	0.312	1.75	1.256	1.08
500-24-24 UNPL	1 1/2-1 1/2	1 7/8-12	2.33	0.328	2.00	1.506	1.31

*PF=PRESS FIT

501 BRAZE 90 DEGREE MALE PIPE ELBOW

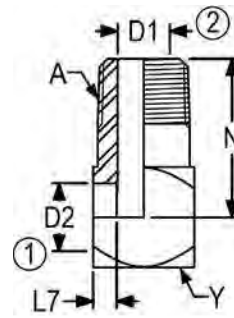

PART NO	TUBE OD	A NPTF	N	L7	Y	D2	D1
501-10-08 UNPL	5/8	1/2-14	1.47	0.218	0.94	0.631	0.48
501-20-16 UNPL	1 1/4	1-11 1/2	2.03	0.312	1.50	1.256	0.84

502 BRAZE 90 DEGREE FEMALE PIPE ELBOW

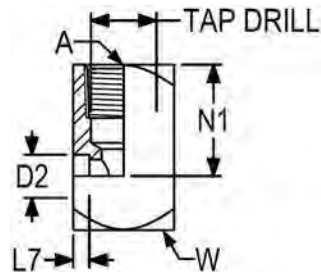

PART NO	TUBE OD	A NPTF	N1	L7	W	D2	TAP DRILL
502-06-06 UNPL	3/8	3/8-18	0.97	0.14	0.88	0.379	0.57

600 BRAZE TUBE RUN/RUN TEE

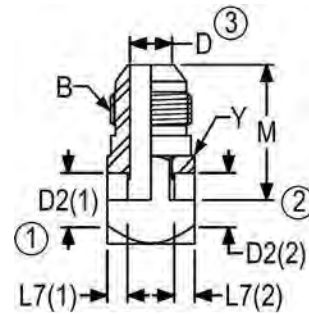

PART NO	TUBE OD	B UN/UNF-2A	M	L7 (1)	L7 (2)	Y	D2 (1)	D2 (2)	D
600-04-04-04 UNPL	1/4-1/4-1/4	7/16-20	0.89	0.125	0.125	0.50	0.254	0.254	0.17
600-05-05-05 PF UNPL	5/16-5/16-5/16	1/2-20	0.95	0.133	0.133	0.56	0.309	0.309	0.23
600-05-05-05 UNPL	5/16-5/16-5/16	1/2-20	0.95	0.133	0.133	0.56	0.316	0.316	0.23
600-06-06-04 UNPL	3/8-3/8-1/4	7/16-20	0.95	0.140	0.140	0.63	0.379	0.379	0.17
600-06-06-06 PF UNPL	3/8-3/8-3/8	9/16-18	1.06	0.140	0.140	0.63	0.372	0.372	0.30
600-06-06-06 UNPL	3/8-3/8-3/8	9/16-18	1.06	0.140	0.140	0.63	0.379	0.379	0.30
600-08-08-08 UNPL	1/2-1/2-1/2	3/4-16	1.25	0.188	0.188	0.81	0.504	0.504	0.39
600-10-10-06 UNPL	5/8-5/8-3/8	9/16-18	1.22	0.150	0.150	0.94	0.484	0.484	0.30
600-10-10-10 UNPL	5/8-5/8-5/8	7/8-14	1.45	0.203	0.203	0.94	0.631	0.631	0.48
600-12-12-08 UNPL	3/4-3/4-1/2	3/4-16	1.31	0.232	0.232	0.94	0.609	0.609	0.39
600-12-12-10 UNPL	3/4-3/4-5/8	7/8-14	1.41	2.00	2.00	0.94	0.766	0.756	0.48
600-12-12-12 UNPL	3/4-3/4-3/4	1 1/16-12	1.66	0.232	0.232	1.13	0.756	0.756	0.61
600-12-12-16 UNPL	3/4-3/4-1	1 5/16-12	1.81	0.232	0.232	1.38	0.756	0.756	0.84
600-16-12-12 UNPL	1-3/4-3/4	1 1/16-12	1.66	0.232	0.232	1.13	1.006	0.756	0.61
600-16-16-16 PF UNPL	1-1-1	1 5/16-12	1.81	2.500	2.500	1.38	1.006	1.006	0.84
600-16-16-16 UNPL	1-1-1	1 5/16-12	1.81	0.250	0.250	1.38	1.006	1.006	0.84
600-20-20-20 UNPL	1 1/4-1 1/4-1 1/4	1 5/8-12	2.06	0.312	0.312	1.75	1.256	1.256	1.08

*PF=PRESS FIT

601 BRAZE MALE PIPE RUN/RUN TEE

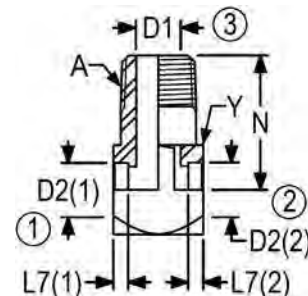

INFORMATION AVAILABLE UPON REQUEST.

602 BRAZE FEMALE PIPE RUN/RUN TEE

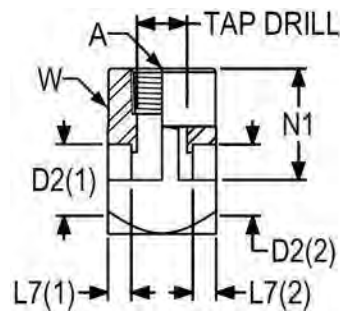

PART NO	TUBE OD	A NPTF	N1	L7 (1)	L7 (2)	W	D2 (1)	D2 (2)	TAP DRILL
602-06-06-2 UNPL	3/8-3/8	1/8-27	0.66	0.140	0.140	0.56	0.379	0.379	0.33
602-10-10-04 UNPL	5/8-5/8	1/4-18	0.94	0.203	0.203	0.94	0.625	0.625	0.43

603 BRAZE JUNCTION TEE

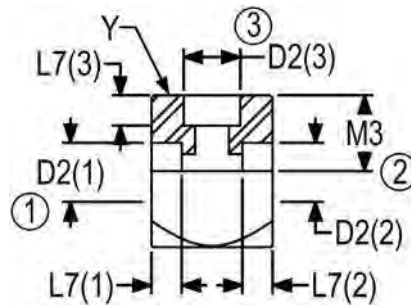

PART NO	TUBE OD	M3	L7 (1)	L7 (2)	L7 (3)	Y	D2 (1)	D2 (2)	D2 (3)
603-04-04-04 UNPL	1/4-1/4-1/4	0.31	0.125	0.125	0.125	0.50	0.254	0.254	0.254
603-06-06-06 UNPL	3/8-3/8-3/8	0.39	0.140	0.140	0.140	0.63	0.379	0.379	0.379

701 BRAZE TUBE RUN TEE

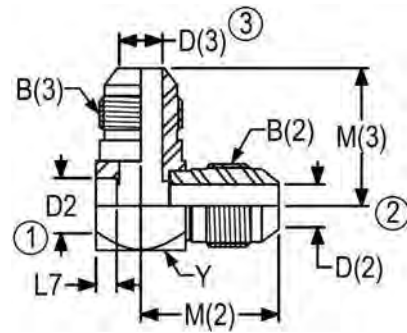

PART NO	TUBE OD	B (2) UN/UNF-2A	B (3) UN/UNF-2A	M (2)	M (3)	Y	L7	D2	D (2)	D (3)
701-04-04-04 UNPL	1/4-1/4-1/4	7/16-20	7/16-20	0.89	0.89	0.50	0.12	0.254	0.17	0.17
701-05-05-05 UNPL	5/16-5/16-5/16	1/2-20	1/2-20	0.95	0.95	0.56	0.13	0.316	0.23	0.23
701-06-06-06 UNPL	3/8-3/8-3/8	9/16-18	9/16-18	1.06	1.06	0.63	0.14	0.379	0.30	0.30
701-10-10-06 UNPL	5/8-5/8-3/8	7/8-14	9/16-18	1.45	1.22	0.94	0.21	0.631	0.48	0.30
701-08-08-08 UNPL	1/2-1/2-1/2	3/4-16	3/4-16	1.25	1.25	0.81	0.18	0.504	0.39	0.39
701-10-10-10 UNPL	5/8-5/8-5/8	7/8-14	7/8-14	1.45	1.45	0.94	0.21	0.631	0.48	0.48
701-12-12-12 UNPL	3/4-3/4-3/4	1 1/6-12	1 1/16-12	1.66	1.66	1.13	0.23	0.756	0.61	0.61
701-14-14-14 PF UNPL	7/8-7/8-7/8	1 3/16-12	1 3/16-12	1.80	1.80	1.25	0.24	0.872	0.72	0.72

*PF=PRESS FIT

702 BRAZE TUBE BRANCH TEE

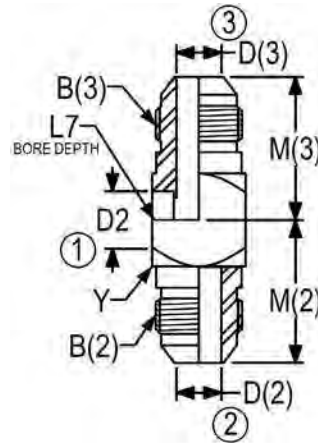

PART NO	TUBE OD	B (2) UN/UNF-2A	B (3) UN/UNF-2A	M (2)	M (3)	Y	L7	D2	D (2)	D (3)
702-04-04-04 UNPL	1/4-1/4-1/4	7/16-20	7/16-20	0.89	0.89	0.50	0.125	0.254	0.17	0.17
702-05-05-05 UNPL	5/16-5/16-5/16	1/2-20	1/2-20	0.95	0.95	0.56	0.133	0.316	0.23	0.23
702-06-04-04 UNPL	5/16-1/4-1/4	7/16-20	7/16-20	0.95	0.95	0.63	0.140	0.379	0.17	0.17
702-06-06-06 UNPL	3/8-3/8-3/8	9/16-18	9/16-18	1.06	1.06	0.63	0.140	0.379	0.30	0.30
702-06-10-10 UNPL	3/8-5/8-5/8	7/8-14	7/8-14	1.45	1.45	0.94	0.140	0.379	0.48	0.48
702-08-06-06 UNPL	1/2-3/8-3/8	9/16-18	9/16-18	1.06	1.06	0.63	0.140	0.504	0.30	0.30
702-08-08-08 PF	1/2-1/2-1/2	3/4-16	3/4-16	1.25	1.25	0.81	0.188	0.497	0.39	0.39
702-08-08-08 UNPL	1/2-1/2-1/2	3/4-16	3/4-16	1.25	1.25	0.81	0.188	0.504	0.39	0.39
702-10-08-08 UNPL	5/8-1/2-1/2	3/4-16	3/4-16	1.25	1.25	0.81	0.188	0.631	0.39	0.39
702-10-10-10 UNPL	5/8-5/8-5/8	7/8-14	7/8-14	1.45	1.45	0.94	0.203	0.631	0.48	0.48
702-10-12-12 UNPL	5/8-3/4-3/4	1 1/16-12	1 1/16-12	1.66	1.66	1.13	0.218	0.631	0.61	0.61
702-12-10-10 UNPL	3/4-5/8-5/8	7/8-14	7/8-14	1.55	1.55	1.13	0.232	0.750	0.48	0.48
702-12-12-12 UNPL	3/4-3/4-3/4	1 1/16-12	1 1/16-12	1.66	1.66	1.13	0.232	0.756	0.61	0.61
702-16-12-12 UNPL	1-3/4-3/4	1 1/16-12	1 1/16-12	1.79	1.79	1.38	0.250	1.006	0.61	0.61
702-16-16-16 UNPL	1-1-1	1 5/16-12	1 5/16-12	1.81	1.81	1.38	0.250	1.006	0.84	0.84
702-20-20-20 UNPL	1 1/4-1 1/4-1 1/4	1 5/8-12	1 5/8-12	2.06	2.06	1.75	0.312	1.256	1.08	1.08

*PF=PRESS FIT

800 BRAZE FEMALE PIPE SWIVEL UNION

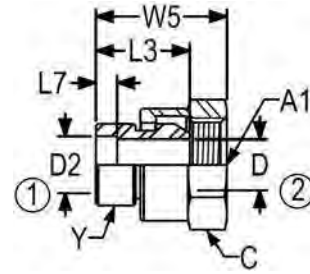

PART NO	TUBE OD	A1 NPSM	W5	L3	L7	Y (DIA)	C	D2	D
800-06-04 UNPL	3/8	1/4-18	0.93	0.74	0.14	0.63	0.69	0.381	0.22
800-06-06 UNPL	3/8	3/8-18	1.02	0.77	0.140	0.63	0.88	0.379	0.30
800-08-08 UNPL	1/2	1/2-14	1.16	0.83	0.19	0.81	1.00	0.504	0.45
800-10-08 UNPL	5/8	1/2-14	1.19	0.86	0.218	0.88	1.00	0.631	0.48
800-16-12 UNPL	1	3/4-14	1.33	1.00	0.250	1.25	1.25	1.006	0.66
800-16-16 UNPL	1	1-11 1/2	1.38	1.00	0.250	1.25	1.50	1.006	0.84

801 BRAZE 90 DEGREE FEMALE PIPE SWIVEL ELBOW

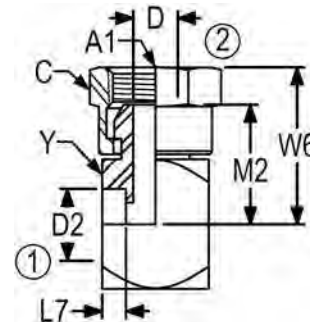

PART NO	TUBE OD	A1 NPSM	W6	M2	C	L7	Y	D2	D
801-08-06 UNPL	1/2	3/8-18	1.06	0.81	0.88	0.16	0.75	0.504	0.33
801-10-08 UNPL	5/8	1/2-14	1.38	1.05	1.00	0.21	0.94	0.631	0.39
801-12-08 UNPL	3/4	1/2-14	1.28	0.95	1.00	0.22	1.00	0.756	0.45
801-16-12 PF UNPL	1	3/4-14	1.57	1.23	1.25	0.25	1.25	0.997	0.63
801-24-16 PF UNPL	1 1/2	1-11 1/2	1.88	1.50	1.50	0.25	1.75	1.497	0.84
801-24-16 UNPL	1 1/2	1-11 1/2	1.88	1.50	1.50	0.25	1.75	1.506	0.84

*PF=PRESS FIT

900 BRAZE 37 DEGREE FEMALE SWIVEL UNION

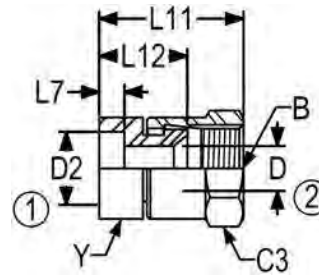

PART NO	TUBE OD	B UN/UNF-2B	L11	L12	C3	L7	Y (DIA)	D2	D
900-05-04 UNPL	5/16-1/4	7/16-20	1.02	0.68	0.56	0.17	0.50	0.317	0.17
900-05-05 UNPL	5/16-5/16	1/2-20	0.94	0.56	0.63	0.156	0.50	0.317	0.23
900-06-06 UNPL	3/8-3/8	9/16-18	1.10	0.73	0.69	0.188	0.63	0.375	0.30
900-10-08 UNPL	5/8-1/2	3/4-16	1.19	0.77	0.88	0.218	0.88	0.628	0.39
900-10-10 UNPL	5/8-5/8	7/8-14	1.40	0.90	1.00	0.218	1.00	0.628	0.48
900-12-10 UNPL	3/4-5/8	7/8-14	1.40	0.90	1.00	0.232	1.00	0.756	0.48
900-12-12 UNPL	3/4-3/4	1 1/16-12	1.61	1.06	1.25	0.232	1.00	0.756	0.61
900-16-16 UNPL	1-1	1 5/16-12	1.78	1.19	1.50	0.250	1.31	1.006	0.84
900-20-16 UNPL	1 1/4-1	1 5/16-12	1.97	1.38	1.50	0.312	1.50	1.256	0.84

901 BRAZE 90 DEGREE-37 DEGREE FEMALE SWIVEL

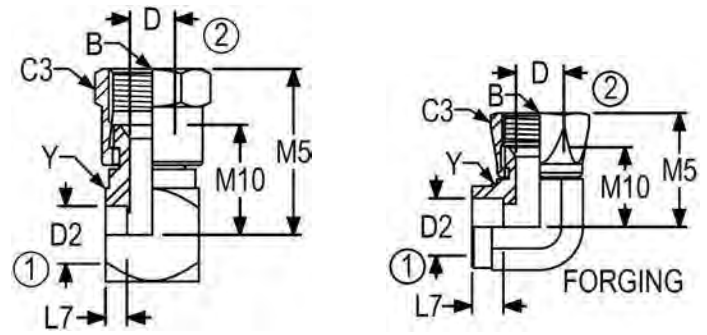

PART NO	TUBE OD	B UN/UNF-2B	M5	M10	C3	L7	Y	D2	D
901-05-05 UNPL	5/16-5/16	1/2-20	1.06	0.69	0.63	0.133	0.56	0.316	0.23
901-06-06 UNPL	3/8-3/8	9/16-18	1.07	0.69	0.69	0.140	0.63	0.379	0.30
901-08-08 UNPL	1/2-1/2	3/4-16	1.38	0.96	0.88	0.188	0.81	0.504	0.39
901-08-08 PF UNPL	1/2-1/2	3/4-16	1.38	0.96	0.88	0.188	0.81	0.497	0.39
901-10-10 PF UNPL	5/8-5/8	7/8-14	1.49	0.99	1.00	0.203	0.94	0.622	0.48
901-12-12 UNPL	3/4-3/4	1 1/16-12	1.78	1.22	1.25	0.23	1.13	0.756	0.61
901-16-16 UNPL-FG	1-1	1 5/16-12	2.00	1.41	1.50	0.55	1.31	1.007	0.84

*PF=PRESS FIT

902 BRAZE 37 DEGREE FEMALE SWIVEL BRANCH TEE

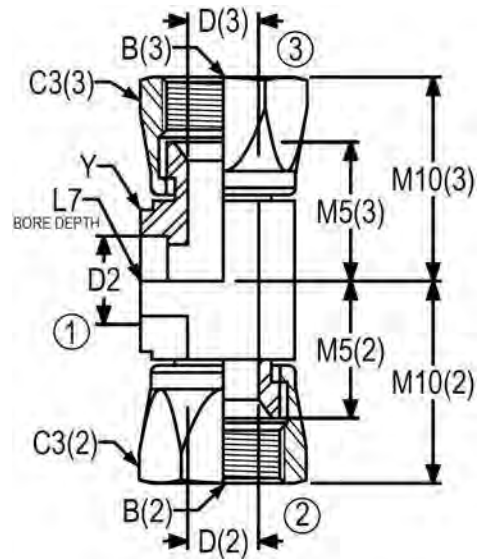

INFORMATION AVAILABLE UPON REQUEST.
CALL CUSTOMER SERVICE FOR DETAILS.

3300-61 BRAZE CODE 61 FLANGED HEAD

ALSO AVAILABLE IN SOLID, CALL CUSTOMER SERVICE FOR DETAILS.

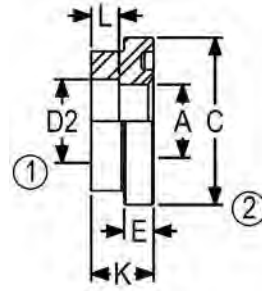

PART NO	TUBE OD	FLANGE SIZE	A	C	E	K	D2	L
3300-61-12 UNPL	3/4	3/4	0.66	1.50	0.26	0.56	0.752	0.250
3300-61-16 UNPL	1	1	0.91	1.75	0.31	0.56	1.006	0.250
3300-61-20 UNPL	1 1/4	1 1/4	1.13	2.00	0.31	0.56	1.256	0.250
3300-61-24 UNPL	1 1/2	1 1/2	1.38	2.38	0.31	0.63	1.504	0.438
3300-61-32 UNPL	2	2	1.88	2.81	0.38	0.63	2.006	0.500
3300-61-48 UNPL	3	3	2.88	4.00	0.38	0.75	3.004	0.562

3300-62 BRAZE CODE 62 FLANGED HEAD

INFORMATION AVAILABLE UPON REQUEST.
CALL CUSTOMER SERVICE FOR DETAILS.

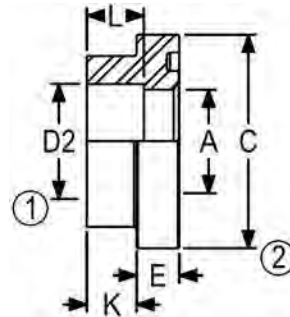

Features. Adapter Unions

Adapter unions provide female pipe swivel connections for use with male pipe or NPT/NPTF hose ends with a 30 degree female seat. **Caution: For proper sealing, ensure that the mating male end has been machined with the proper 30 degree female seat.** The adapter unions described in this section include female pipe swivel fittings with NPTF (Dryseal) male or female pipe ends and SAE straight thread O-Ring stud ends. Pipe thread connections are used in a wide variety of applications and provide reliable metal to metal sealing. Because of the tapered NPTF thread design, pipe thread connections are not recommended for applications that require repeated re-assembly or precise orientation of the fitting after tightening. For these applications, use of the SAE adjustable O-Ring stud end is recommended.

Performance

Where applicable, fittings are designed and qualified to the requirements of SAE J514. Straight thread O-Ring stud ends conform to SAE J514 and/or SAE J1926/3/ISO 11926-3.

Construction

Unless otherwise specified, fittings are machined from cold drawn carbon steel barstock and forgings. Standard plating is electrodeposited zinc with a clear trivalent chromate conversion coating in accordance with ASTM B633 (Type V SC2). The minimum salt spray resistance is 240 hours to red corrosion when tested in accordance with ASTM B117.

Threads

Straight Threads: External straight threads conform to the Unified National Class 2A. Maximum diameters of plated external threads may conform to Class 3A maximum diameters after plating.

NPTF Threads: Male and female pipe threads conform to the Dryseal American Standard Taper Pipe Thread (SAE J476a, NPTF) Series which will provide pressure tight joints without the use of a lubricant or sealer. Use of these fittings with non-dryseal NPT pipe or hose ends is not recommended for high-pressure applications.

Note: Where not functionally objectionable, use of a compatible lubricant/sealant is recommended for either NPT or NPTF threads to minimize the possibility of galling in assembly.

NPSM Swivels: Female threads for adapter union swivel nuts conform to the American Standard Straight Pipe Thread (NPSM) Series. These threads mate with either NPT or NPTF Series male threads to provide a mechanical connection between the adapter and mating male end. Sealing is provided by metal to metal contact between the machined 30 degree female seat on the NPT/NPTF male end and the nose of the swivel end. The NPSM swivel threads are not a sealing member.

Caution: For proper sealing, ensure that the mating male end has been machined with the proper 30 degree female seat.

Assembly Information

For assembly instructions, refer to the Technical Data Section for the appropriate fitting end. Also, refer to the Technical Data Section for recommendations regarding tubing pressure ratings, tube flares and hose/tube routing information. Please note the following:

In the design and fabrication of tubing or hose runs for any hydraulic system, precautions should be taken to allow for sufficient adjustment of the hose or tubing so that proper alignment can be attained at the fitting connections. Improper fit-up or misalignment should be corrected before final connections are made. Location of fitting connections should be planned to maximize accessibility. Whenever possible, use a torque wrench to tighten connections to the recommended torque.

Ordering information

Size of fittings are indicated by dash number relating to sixteenths of an inch for the nominal O.D. of the pipe size used. Example: 1/2 inch pipe = 8/16 or (-8) size.

Order standard fittings from appropriate chart indicating required dash numbers. For example, 1404-08-08 is 1/2" male pipe thread to 1/2" female pipe swivel. Jump size 1404-08-06 is 1/2" male pipe thread to 3/8" female pipe swivel. Pictorial views for each fitting style indicate the correct numbering sequence for fitting ends.

If information is needed for jump sizes not shown, please contact customer service for engineering assistance.

Table JU1. Pressure Ratings for Fittings With NPTF Pipe Threads and Adapter Unions						
Nom. Pipe Size		Thread Size			Working Pressures	
Nom SAE Dash Size	Nom Inch Pipe O.D.	Dryseal Pipe Thread (NPTF ¹) Male and Female	Straight Pipe Thread (NPSM ²) Female Swivels	SAE J1926/3/ISO 11926-3 O-Ring Port Thread Size (Notes 3&4)	Adapter Unions	
					MPa	psi
-02	1/8	1/8-27	1/8-27	5/16-24 UNF	34.5	5,000
-04	1/4	1/4-18	1/4-18	7/16-20 UNF	34.5	5,000
-06	3/8	3/8-18	3/8-18	9/16-18 UNF	27.6	4,000
-08	1/2	1/2-14	1/2-14	3/4-16 UNF	24.1	3,500
-12	3/4	3/4-14	3/4-14	1-1/16-12 UN	15.5	2,250
-16	1	1-11-1/2	1-11-1/2	1-5/16-12 UN	13.8	2,000
-20	1 1/4	1-1/4-11-1/2	1-1/4-11-1/2	1-5/8-12 UN	11.2	1,625
-24	1 1/2	1-1/2-11-1/2	1-1/2-11-1/2	1-7/8-12 UN	8.6	1,250
-32	2	2-11-1/2	2-11-1/2	2-1/2-12 UN	7.8	1,125

1) Dryseal American Standard Taper Pipe Thread

2) American Standard Straight Pipe Thread for Mechanical Joints

3) Threads per SAE J475 Class 2A ext. Class 2B int. (Ref. ISO-263/ISO-R725)

4) Unified class 2B threads apply to swivel nuts and with minor diameter modified to class 3B limits for locknuts

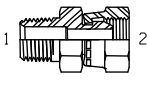
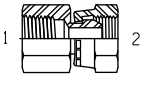
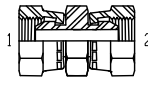
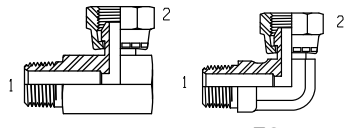
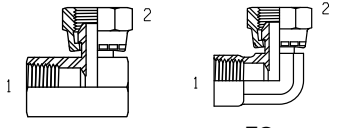
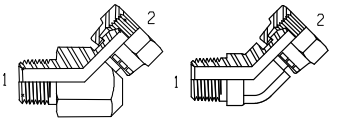
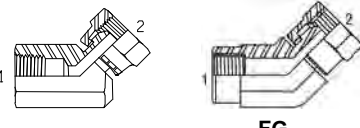
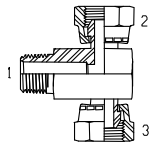
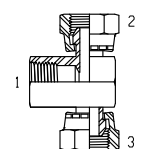
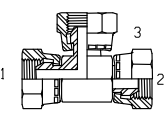
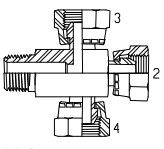
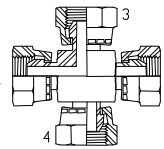
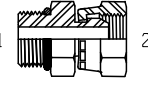
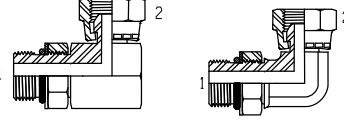
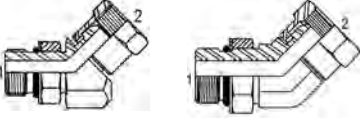
<p>(140130)</p>  <p>1404- (1)Male Pipe (2)Female Pipe Swivel</p>	<p>(140131)</p>  <p>1405- (1)Female Pipe (2)Female Pipe Swivel</p>	<p>(140132)</p>  <p>1406- (1&2)Female Pipe Swivel</p>	<p>(140230)</p>  <p>1501- (1)Male Pipe (2)Female Pipe Swivel</p> <p>FG</p>	<p>(140231)</p>  <p>1502- (1)Female Pipe (2)Female Pipe Swivel</p> <p>FG</p>		
<p>(140330)</p>  <p>1503- (1)Male Pipe (2)Female Pipe Swivel</p> <p>FG</p>		<p>(140331)</p>  <p>1504- (1)Female Pipe (2)Female Pipe Swivel</p> <p>FG</p>		<p>(140332)</p>  <p>1601- (1)Male Pipe (2&3)Female Pipe Swivel</p>	<p>(140333)</p>  <p>1602- (1)Female Pipe (2&3)Female Pipe Swivel</p>	<p>(140334)</p>  <p>1603- (1,2&3)Female Pipe Swivel</p>
<p>(140156)</p>  <p>1604- (1)Male Pipe (2,3&4)Female Pipe Swivel</p>	<p>(140157)</p>  <p>1605- (1,2,3&4)Female Pipe Swivel</p>	<p>(140157)</p>  <p>6900-O- (1)Male O-Ring (2)Female Pipe Swivel</p>	<p>(140257)</p>  <p>6901-NWO- (1)Adjustable O-Ring (2)Female Pipe Swivel</p> <p>FG</p>		<p>(140357)</p>  <p>6902-NWO- (1)Adjustable O-Ring (2)Female Pipe Swivel</p> <p>FG</p>	

1404 FEMALE ADAPTER UNION TO MALE

PIPE

SAE J514 140130

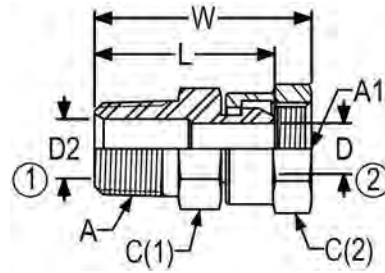

PART NO	A NPTF	A1 NPSM	W	L	C (1)	C (2)	D2	D
1404-02-02	1/8-27	1/8-27	1.15	1.00	0.50	0.56	0.19	0.13
1404-02-04	1/8-27	1/4-18	1.25	1.06	0.63	0.69	0.19	0.19
1404-04-02	1/4-18	1/8-27	1.34	1.19	0.63	0.56	0.28	0.13
1404-04-04	1/4-18	1/4-18	1.44	1.25	0.63	0.69	0.28	0.22
1404-04-06	1/4-18	3/8-18	1.56	1.31	0.81	0.88	0.28	0.28
1404-04-08	1/4-18	1/2-14	1.75	1.42	0.94	1.00	0.28	0.28
1404-06-04	3/8-18	1/4-18	1.50	1.31	0.75	0.69	0.41	0.22
1404-06-06	3/8-18	3/8-18	1.56	1.31	0.81	0.88	0.41	0.33
1404-06-08	3/8-18	1/2-14	1.75	1.42	0.94	1.00	0.41	0.41
1404-08-04	1/2-14	1/4-18	1.75	1.56	0.88	0.69	0.53	0.22
1404-08-06	1/2-14	3/8-18	1.81	1.56	0.88	0.88	0.53	0.33
1404-08-08	1/2-14	1/2-14	1.94	1.61	0.94	1.00	0.53	0.45
1404-08-12	1/2-14	3/4-14	2.06	1.73	1.13	1.25	0.53	0.53
1404-12-06	3/4-14	3/8-18	1.82	1.57	1.13	0.88	0.72	0.33
1404-12-08	3/4-14	1/2-14	1.95	1.62	1.13	1.00	0.72	0.45
1404-12-12	3/4-14	3/4-14	2.06	1.73	1.13	1.25	0.72	0.63
1404-12-16	3/4-14	1-11 1/2	2.18	1.81	1.50	1.50	0.72	0.72
1404-12-20	3/4-14	1 1/4-11 1/2	2.24	1.82	1.75	1.88	0.72	0.94
1404-16-08	1-11 1/2	1/2-14	2.18	1.85	1.38	1.00	0.94	0.45
1404-16-12	1-11 1/2	3/4-14	2.31	1.98	1.38	1.25	0.94	0.63
1404-16-16	1-11 1/2	1-11 1/2	2.38	2.00	1.50	1.50	0.94	0.84
1404-16-20	1-11 1/2	1 1/4-11 1/2	2.46	2.03	1.75	1.88	0.94	0.94
1404-16-24	1-11 1/2	1 1/2-11 1/2	2.06	1.64	2.13	2.13	0.94	1.26
1404-20-16	1 1/4-11 1/2	1-11 1/2	2.38	2.00	1.75	1.50	1.25	0.84
1404-20-20	1 1/4-11 1/2	1 1/4-11 1/2	2.49	2.06	1.75	1.88	1.25	1.01
1404-20-24	1 1/4-11 1/2	1 1/2-11 1/2	2.51	2.09	2.13	2.13	1.25	1.25
1404-24-20	1 1/2-11 1/2	1 1/4-11 1/2	2.61	2.19	2.00	1.88	1.50	1.01
1404-24-24	1 1/2-11 1/2	1 1/2-11 1/2	2.55	2.13	2.13	2.13	1.50	1.26
1404-32-32	2-11 1/2	2-11 1/2	2.79	2.38	2.50	2.63	1.94	1.72

1405 FEMALE ADAPTER UNION TO FEMALE PIPE

SAE J514 140131

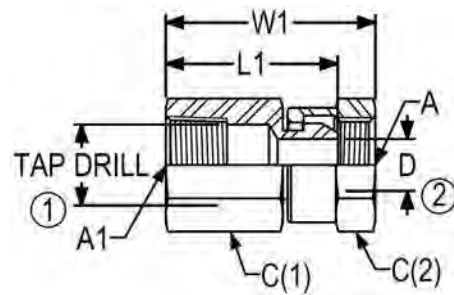

PART NO	A1 NPTF	A NPSM	W1	L1	C (1)	C (2)	TAP DRILL	D
1405-02-02	1/8-27	1/8-27	1.03	0.88	0.56	0.56	0.33	0.13
1405-02-04	1/8-27	1/4-18	1.44	1.25	0.56	0.69	0.33	0.22
1405-04-02	1/4-18	1/8-27	1.34	1.19	0.69	0.56	0.43	0.13
1405-04-04	1/4-18	1/4-18	1.44	1.25	0.69	0.69	0.43	0.22
1405-04-06	1/4-18	3/8-18	1.50	1.25	0.69	0.88	0.43	0.33
1405-06-04	3/8-18	1/4-18	1.50	1.31	0.88	0.69	0.57	0.22
1405-06-06	3/8-18	3/8-18	1.56	1.31	0.88	0.88	0.57	0.33
1405-06-08	3/8-18	1/2-14	1.83	1.30	0.88	1.00	0.57	0.45
1405-08-04	1/2-14	1/4-18	1.75	1.56	1.00	0.69	0.70	0.22
1405-08-06	1/2-14	3/8-18	1.70	1.45	1.00	0.88	0.70	0.33
1405-08-08	1/2-14	1/2-14	1.83	1.50	1.00	1.00	0.70	0.45
1405-12-08	3/4-14	1/2-14	1.83	1.54	1.25	1.00	0.91	0.45
1405-12-12	3/4-14	3/4-14	1.96	1.63	1.25	1.25	0.91	0.63
1405-12-16	3/4-14	1-11 1/2	2.30	1.92	1.25	1.50	0.91	0.84
1405-16-12	1-11 1/2	3/4-14	2.23	1.90	1.50	1.25	1.14	0.63
1405-16-16	1-11 1/2	1-11 1/2	2.30	1.92	1.50	1.50	1.14	0.84
1405-20-20	1 1/4-11 1/2	1 1/4-11 1/2	2.43	2.00	1.88	1.88	1.48	1.01
1405-24-24	1 1/2-11 1/2	1 1/2-11 1/2	2.42	2.00	2.13	2.13	1.72	1.26
1405-32-32	2-11 1/2	2-11 1/2	2.54	2.13	2.63	2.63	2.19	1.72

1406 FEMALE ADAPTER UNION (DOUBLE SWIVEL)

INFORMATION AVAILABLE UPON REQUEST.
CALL CUSTOMER SERVICE FOR DETAILS.

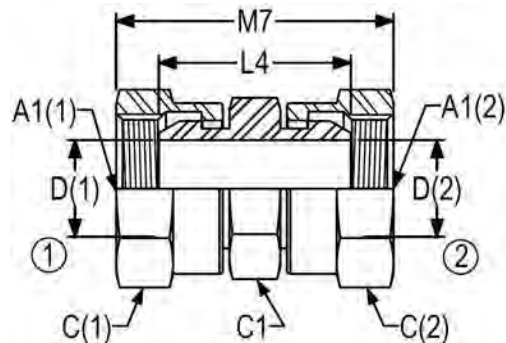

**1501 90 DEGREE FEMALE ADAPTER
UNION TO MALE PIPE**
SAE J514 140230

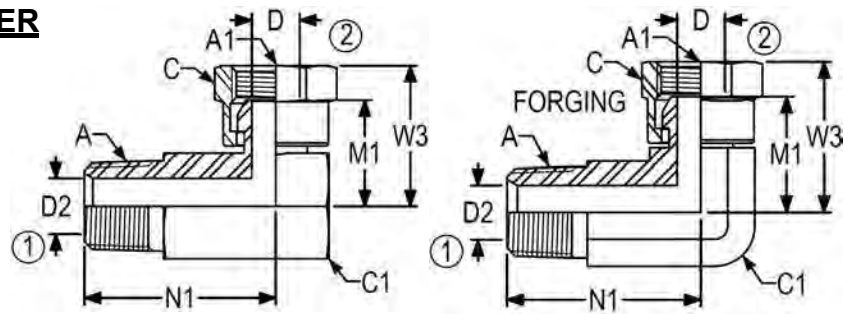

*Non forging parts are brazed construction

PART NO	A NPTF	A1 NPSM	N1	W3	M1	C	C1	D2	D
1501-02-02	1/8-27	1/8-27	0.94	0.85	0.70	0.56	0.56	0.19	0.13
1501-02-02-FG	1/8-27	1/8-27	0.72	0.85	0.70	0.56	0.44	0.19	0.13
1501-02-04-FG	1/8-24	1/4-18	1.06	0.98	0.79	0.69	0.50	0.19	0.22
1501-04-02	1/4-18	1/8-27	1.19	0.91	0.76	0.56	0.69	0.28	0.13
1501-04-02-FG	1/4-18	1/8-27	1.09	0.91	0.76	0.56	0.50	0.28	0.23
1501-04-04	1/4-18	1/4-18	1.19	0.98	0.79	0.69	0.69	0.28	0.22
1501-04-04-FG	1/4-18	1/4-18	1.09	0.98	0.79	0.69	0.50	0.28	0.22
1501-04-06	1/4-18	3/8-18	1.50	1.20	0.95	0.88	0.88	0.28	0.33
1501-04-06-FG	1/4-18	3/8-18	1.09	1.20	0.95	0.88	0.75	0.28	0.33
1501-04-08	1/4-18	1/2-14	1.56	1.33	1.00	1.00	1.00	0.28	0.45
1501-06-04	3/8-18	1/4-18	1.50	1.07	0.88	0.69	0.88	0.41	0.22
1501-06-04-FG	3/8-18	1/4-18	1.22	1.07	0.88	0.69	0.75	0.41	0.22
1501-06-06	3/8-18	3/8-18	1.50	1.20	0.95	0.88	0.88	0.41	0.33
1501-06-06-FG	3/8-18	3/8-18	1.22	1.20	0.95	0.88	0.75	0.41	0.33
1501-06-08	3/8-18	1/2-14	1.56	1.33	1.00	1.00	1.00	0.41	0.45
1501-06-08-FG	3/8-18	1/2-14	1.22	1.33	1.00	1.00	0.87	0.41	0.45
1501-06-12	3/8-18	3/4-14	1.81	1.61	1.27	1.25	1.25	0.41	0.63
1501-08-04	1/2-14	1/4-18	1.81	1.13	0.94	0.69	1.00	0.53	0.22
1501-08-04-FG	1/2-14	1/4-18	1.47	1.13	0.94	0.69	0.87	0.53	0.22
1501-08-06	1/2-14	3/8-18	1.81	1.26	1.01	0.88	1.00	0.53	0.33
1501-08-06-FG	1/2-14	3/8-18	1.47	1.26	1.01	0.88	0.88	0.53	0.33
1501-08-08	1/2-14	1/2-14	1.81	1.33	1.00	1.00	1.00	0.53	0.45
1501-08-08-FG	1/2-14	1/2-14	1.47	1.34	1.01	1.00	0.88	0.53	0.45
1501-08-12	1/2-14	3/4-14	2.00	1.60	1.26	1.25	1.25	0.53	0.63
1501-08-12-FG	1/2-14	3/4-14	1.47	1.60	1.27	1.25	1.06	0.53	0.63
1501-12-06	3/4-14	3/8-18	2.00	1.38	1.13	0.88	1.25	0.72	0.33
1501-12-06-FG	3/4-14	3/8-18	1.59	1.38	1.13	0.88	1.06	0.72	0.33
1501-12-08	3/4-14	1/2-14	2.00	1.45	1.13	1.00	1.25	0.72	0.45
1501-12-08-FG	3/4-14	1/2-14	1.59	1.46	1.13	1.00	1.06	0.72	0.42
1501-12-12	3/4-14	3/4-14	2.00	1.60	1.26	1.25	1.25	0.72	0.63
1501-12-12-FG	3/4-14	3/4-14	1.59	1.60	1.27	1.25	1.31	0.72	0.63
1501-12-16	3/4-14	1-11 1/2	2.19	1.77	1.40	1.50	1.50	0.72	0.84
1501-12-16-FG	3/4-14	1-11 1/2	1.97	1.78	1.40	1.50	1.31	0.72	0.84
1501-12-20	3/4-14	1 1/4-11 1/2	2.34	2.09	1.67	1.88	1.88	0.72	1.01
1501-16-08	1-11 1/2	1/2-14	2.38	1.58	1.25	1.00	1.50	0.94	0.45
1501-16-08-FG	1-11 1/2	1/2-14	1.97	1.58	1.25	1.00	1.31	0.94	0.45

1501 90 DEGREE FEMALE ADAPTER UNION TO MALE PIPE (Con't)

SAE J514 140230

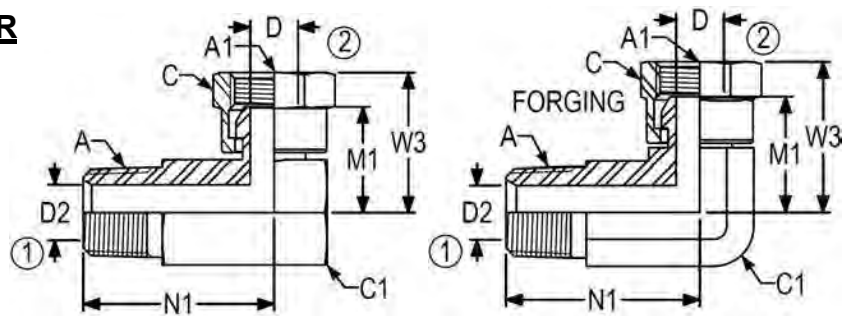

*Non forging parts are brazed construction

PART NO	A NPTF	A1 NPSM	N1	W3	M1	C	C1	D2	D
1501-16-12	1-11 1/2	3/4-14	2.38	1.72	1.39	1.25	1.50	0.94	0.63
1501-16-12-FG	1-11 1/2	3/4-14	1.97	1.73	1.39	1.25	1.31	0.94	0.63
1501-16-16	1-11 1/2	1-11 1/2	2.38	1.77	1.40	1.50	1.50	0.94	0.84
1501-16-16-FG	1-11 1/2	1-11 1/2	1.97	1.78	1.40	1.50	1.31	0.94	0.84
1501-16-20	1-11 1/2	1 1/4-11 1/2	2.53	2.09	1.67	1.88	1.88	0.94	1.01
1501-16-20-FG	1-11 1/2	1 1/4-11 1/2	2.35	2.10	1.67	1.88	1.63	0.94	1.01
1501-16-24	1-11 1/2	1 1/2-11 1/2	2.75	1.76	1.34	2.13	2.13	0.94	1.26
1501-20-12	1 1/4-11 1/2	3/4-14	2.56	1.91	1.58	1.25	1.88	1.25	0.63
1501-20-16	1 1/4-11 1/2	1-11 1/2	2.63	1.96	1.59	1.50	1.88	1.25	0.84
1501-20-16-FG	1 1/4-11 1/2	1-11 1/2	2.38	1.97	1.59	1.50	1.26	1.25	0.84
1501-20-20	1 1/4-11 1/2	1 1/4-11 1/2	2.63	2.09	1.67	1.88	1.88	1.25	1.01
1501-20-20-FG	1 1/4-11 1/2	1 1/4-11 1/2	2.38	2.10	1.67	1.88	1.63	1.25	1.01
1501-20-24	1 1/4-11 1/2	1 1/2-11 1/2	2.78	2.18	1.76	2.13	2.13	1.25	1.26
1501-24-20	1 1/2-11 1/2	1 1/4-11 1/2	2.81	2.22	1.79	1.88	2.13	1.50	1.01
1501-24-24	1 1/2-11 1/2	1 1/2-11 1/2	2.81	2.19	1.76	2.13	2.13	1.50	1.26
1501-24-24-FG	1 1/2-11 1/2	1 1/2-11 1/2	2.64	2.19	1.76	1.88	1.87	1.50	1.26
1501-32-32	2-11 1/2	2-11 1/2	3.13	2.50	2.08	2.63	2.63	1.94	1.72
1501-32-32-FG	2-11 1/2	2-11 1/2	3.13	2.62	2.21	2.63	2.50	1.94	1.72
1501-L-08-08-FG	1/2-14	1/2-14	1.78	1.33	1.00	1.00	0.88	0.53	0.45
1501-L-12-12-FG	3/4-14	3/4-14	2.00	1.52	1.19	1.25	1.06	0.72	0.63
1501-LL-02-02-FG	1/8-27	1/8-27	1.64	0.85	0.70	0.56	0.44	0.19	0.13

**1502 90 DEGREE FEMALE ADAPTER
UNION TO FEMALE PIPE**
SAE J514 140231

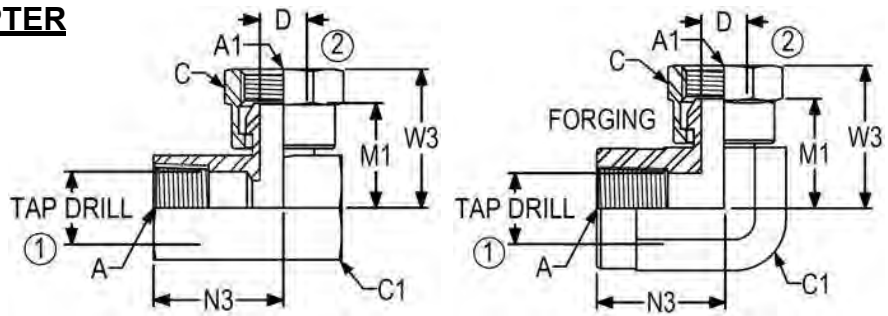

*Non forging parts are brazed construction

PART NO	A NPTF	A1 NPSM	N3	W3	M1	C	C1	TAP DRILL	D
1502-02-02	1/8-27	1/8-27	0.69	0.85	0.70	0.56	0.56	0.33	0.13
1502-02-02-FG	1/8-27	1/8-27	0.75	0.89	0.74	0.56	0.56	0.33	0.13
1502-04-02	1/8-18	1/8-27	0.94	0.91	0.76	0.56	0.69	0.43	0.13
1502-04-04	1/4-18	1/4-18	0.94	0.98	0.79	0.69	0.69	0.43	0.22
1502-04-04-FG	1/4-18	1/4-18	0.94	0.97	0.78	0.69	0.69	0.43	0.22
1502-04-06	1/4-18	3/8-18	1.06	1.20	0.94	0.88	0.88	0.43	0.33
1502-06-04	3/8-18	1/4-18	1.06	1.07	0.88	0.69	0.88	0.57	0.22
1502-06-06	3/8-18	3/8-18	1.06	1.20	0.94	0.88	0.88	0.57	0.33
1502-06-08	3/8-18	1/2-14	1.25	1.33	1.00	1.00	1.00	0.57	0.45
1502-08-04	1/2-14	1/4-18	1.25	1.13	0.94	0.69	1.00	0.70	0.22
1502-08-06	1/2-14	3/8-18	1.25	1.26	1.01	0.88	1.00	0.70	0.33
1502-08-08	1/2-14	1/2-14	1.25	1.33	1.00	1.00	1.00	0.70	0.45
1502-08-12	1/2-14	3/4-14	1.44	1.60	1.26	1.25	1.25	0.70	0.63
1502-12-08	3/4-14	1/2-14	1.44	1.45	1.13	1.00	1.25	0.91	0.45
1502-12-12	3/4-14	3/4-14	1.44	1.60	1.26	1.25	1.25	0.91	0.63
1502-12-16	3/4-14	1-11 1/2	1.75	1.77	1.40	1.50	1.50	0.91	0.84
1502-16-12	1-11 1/2	3/4-14	1.75	1.72	1.39	1.25	1.50	1.14	0.63
1502-16-16	1-11 1/2	1-11 1/2	1.75	1.77	1.40	1.50	1.50	1.14	0.84
1502-20-16	1 1/4-11 1/2	1-11 1/2	2.00	1.97	1.59	1.50	1.88	1.48	0.84
1502-20-20	1 1/4-11 1/2	1 1/4-11 1/2	2.00	2.09	1.67	1.88	1.88	1.48	1.01
1502-24-24	1 1/2-11 1/2	1 1/2-11 1/2	2.25	2.19	1.76	2.13	2.13	1.72	1.26
1502-32-32	2-11 1/2	2-11 1/2	2.50	2.50	2.08	2.63	2.63	2.19	1.72

**1503 45 DEGREE FEMALE ADAPTER
UNION TO MALE PIPE**
SAE J514 140330

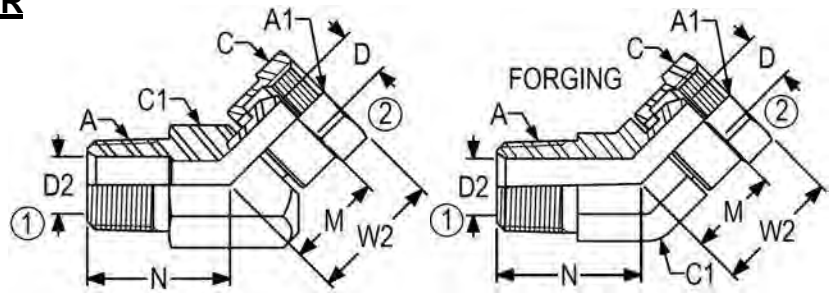

*Non forging parts are brazed construction

PART NO	A NPTF	A1 NPSM	N	W2	M	C	C1	D2	D
1503-02-02	1/8-27	1/8-27	0.63	0.75	0.60	0.56	0.56	0.19	0.13
1503-02-02-FG	1/8-27	1/8-27	0.63	0.75	0.60	0.56	0.44	0.19	0.13
1503-02-04	1/8-27	1/4-18	0.56	0.84	0.65	0.69	0.69	0.19	0.22
1503-02-04-FG	1/8-27	1/4-18	0.56	0.84	0.56	0.69	0.56	0.19	0.22
1503-04-02	1/4-18	1/8-27	0.94	0.79	0.64	0.69	0.69	0.28	0.13
1503-04-04	1/4-18	1/4-18	0.94	0.88	0.69	0.69	0.69	0.28	0.22
1503-04-04-FG	1/4-18	1/4-18	0.91	0.91	0.72	0.69	0.56	0.28	0.22
1503-04-06	1/4-18	3/8-18	1.06	1.00	0.75	0.88	0.88	0.28	0.33
1503-06-04	3/8-18	1/4-18	1.06	0.97	0.78	0.69	0.88	0.41	0.22
1503-06-06	3/8-18	3/8-18	1.06	1.00	0.75	0.88	0.88	0.41	0.33
1503-06-06-FG	3/8-18	3/8-18	1.12	1.20	0.95	0.88	0.75	0.41	0.33
1503-06-08	3/8-18	1/2-14	1.19	1.11	0.78	1.00	1.00	0.41	0.45
1503-06-08-FG	3/8-18	1/2-14	1.19	1.11	0.78	1.00	0.88	0.41	0.45
1503-08-04	1/2-14	1/4-18	1.31	1.00	0.81	0.69	1.00	0.53	0.22
1503-08-06	1/2-14	3/8-18	1.31	1.13	0.88	0.88	1.00	0.53	0.33
1503-08-06-FG	1/2-14	3/8-18	1.31	1.13	0.88	0.88	0.88	0.53	0.33
1503-08-08	1/2-14	1/2-14	1.31	1.21	0.88	1.00	1.00	0.53	0.45
1503-08-08-FG	1/2-14	1/2-14	1.44	1.27	0.94	1.00	0.88	0.53	0.45
1503-08-12	1/2-14	3/4-14	1.50	1.41	1.08	1.25	1.25	0.53	0.63
1503-08-12-FG	1/2-14	3/4-14	1.50	1.41	1.08	1.25	1.06	0.53	0.63
1503-12-06	3/4-14	3/8-18	1.50	1.10	0.85	0.88	1.25	0.72	0.33
1503-12-08	3/4-14	1/2-14	1.50	1.21	0.88	1.00	1.25	0.72	0.45
1503-12-08-FG	3/4-14	1/2-14	1.50	1.21	0.88	1.00	1.06	0.72	0.45
1503-12-12	3/4-14	3/4-14	1.50	1.33	1.00	1.25	1.25	0.72	0.63
1503-12-12-FG	3/4-14	3/4-14	1.50	1.33	1.00	1.25	1.06	0.72	0.63
1503-12-16	3/4-14	1-11 1/2	1.31	1.42	1.05	1.50	1.50	0.72	0.84
1503-12-16-FG	3/4-14	1-11 1/2	1.31	1.42	1.05	1.50	1.31	0.72	0.84
1503-16-12	1-11 1/2	3/4-14	1.50	1.37	1.03	1.25	1.50	0.94	0.63
1503-16-12-FG	1-11 1/2	3/4-14	1.50	1.37	1.03	1.25	1.31	0.94	0.63
1503-16-16	1-11 1/2	1-11 1/2	1.44	1.51	1.13	1.50	1.50	0.94	0.84
1503-16-16-FG	1-11 1/2	1-11 1/2	1.44	1.51	1.13	1.50	1.31	0.94	0.84

**1503 45 DEGREE FEMALE ADAPTER
UNION TO MALE PIPE (Con't)**
SAE J514 140330

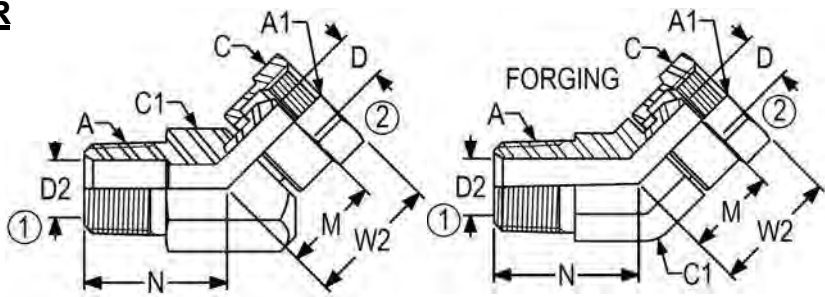

*Non forging parts are brazed construction

PART NO	A NPTF	A1 NPSM	N	W2	M	C	C1	D2	D
1503-16-20	1-11 1/2	1 1/4-11 1/2	1.75	1.58	1.16	1.88	1.88	0.94	1.01
1503-20-16	1 1/4-11 1/2	1-11 1/2	1.80	1.67	1.30	1.50	1.88	1.25	0.84
1503-20-16-FG	1 1/4-11 1/2	1-11 1/2	1.80	1.67	1.30	1.50	1.63	1.25	0.84
1503-20-20	1 1/4-11 1/2	1 1/4-11 1/2	1.75	1.71	1.28	1.88	1.88	1.25	1.01
1503-20-20-FG	1 1/4-11 1/2	1 1/4-11 1/2	1.80	1.71	1.28	1.88	1.63	1.25	1.01
1503-24-24	1 1/2-11 1/2	1 1/2-11 1/2	1.94	1.80	1.38	2.13	2.13	1.50	1.26
1503-24-24-FG	1 1/2-11 1/2	1 1/2-11 1/2	1.94	1.80	1.38	2.13	1.88	1.50	1.26
1503-32-32	2-11 1/2	2-11 1/2	2.00	1.94	1.53	2.63	2.63	1.94	1.72
1503-32-32-FG	2-11 1/2	2-11 1/2	2.00	1.97	1.55	2.63	2.50	1.94	1.72

**1504 45 DEGREE FEMALE ADAPTER
UNION TO FEMALE PIPE**
SAE J514 140331

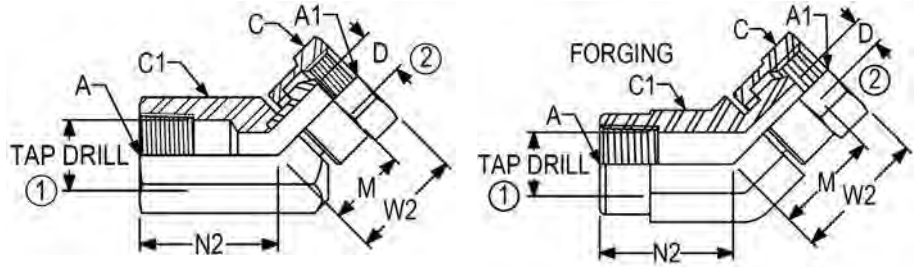

PART NO	A NPTF	A1 NPSM	N2	W2	M	C	C1	TAP DRILL	D
1504-02-02	1/8-27	1/8-27	0.67	0.79	0.65	0.56	0.56	0.33	0.13
1504-02-04	1/8-27	1/4-18	0.91	0.85	0.66	0.69	0.69	0.33	0.22
1504-04-04	1/4-18	1/4-18	0.91	0.85	0.66	0.69	0.69	0.43	0.22
1504-04-04-FG	1/4-18	1/4-18	0.91	0.91	0.72	0.69	0.69	0.43	0.22
1504-06-04	3/8-18	1/4-18	1.06	0.93	0.74	0.69	0.88	0.57	0.22
1504-06-06	3/8-18	3/8-18	1.06	1.01	0.76	0.88	0.88	0.57	0.33
1504-06-08	3/8-18	1/2-14	1.38	1.13	0.80	1.00	1.00	0.57	0.45
1504-08-06	1/2-14	3/8-18	1.38	1.04	0.79	0.88	1.00	0.70	0.33
1504-08-08	1/2-14	1/2-14	1.38	1.11	0.79	1.00	1.00	0.70	0.45
1504-12-08	3/4-14	1/2-14	1.25	1.31	0.98	1.00	1.25	0.91	0.45
1504-12-12	3/4-14	3/4-14	1.25	1.34	1.01	1.25	1.25	0.91	0.63
1504-16-12	1-11 1/2	3/4-14	1.50	1.49	1.15	1.25	1.50	1.14	0.63
1504-16-16	1-11 1/2	1-11 1/2	1.50	1.46	1.09	1.50	1.50	1.14	0.84
1504-20-20	1 1/4-11 1/2	1 1/4-11 1/2	1.78	1.76	1.34	1.88	1.88	1.48	1.01
1504-24-24	1 1/2-11 1/2	1 1/2-11 1/2	1.97	1.77	1.35	2.13	2.13	1.72	1.26

**1601 FEMALE ADAPTER UNION TO MALE
PIPE BRANCH**

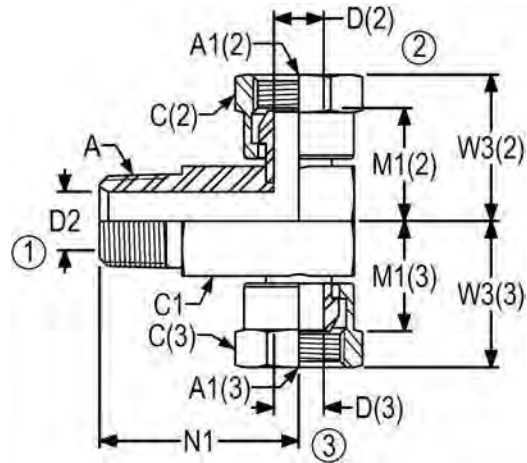

PART NO	A NPTF	A1 (2) NPSM	A1 (3) NPSM	N1	W3 (2)	M1 (2)	W3 (3)	M1 (3)	C (2)	C (3)
1601-02-02-02	1/8-27	1/8-27	1/8-27	0.94	0.85	0.70	0.85	0.70	0.56	0.56
1601-04-04-04	1/4-18	1/4-18	1/4-18	1.19	0.98	0.79	0.98	0.79	0.69	0.69
1601-04-06-06	1/4-18	3/8-18	3/8-18	1.50	1.20	0.95	1.20	0.95	0.88	0.88
1601-06-04-04	3/8-18	1/4-18	1/4-18	1.50	1.07	0.88	1.07	0.88	0.69	0.69
1601-06-06-06	3/8-18	3/8-18	3/8-18	1.50	1.20	0.95	1.20	0.95	0.88	0.88
1601-08-04-04	1/2-14	1/4-18	1/4-18	1.81	1.13	0.94	1.13	0.94	0.69	0.69
1601-08-06-06	1/2-14	3/8-18	3/8-18	1.81	1.26	1.01	1.26	1.01	0.88	0.88
1601-08-08-08	1/2-14	1/2-14	1/2-14	1.81	1.33	1.00	1.33	1.00	1.00	1.00
1601-08-12-12	1/2-14	3/4-14	3/4-14	2.00	1.60	1.26	1.60	1.26	1.25	1.25
1601-12-08-08	3/4-14	1/2-14	1/2-14	2.00	1.45	1.13	1.45	1.13	1.00	1.00
1601-12-12-12	3/4-14	3/4-14	3/4-14	2.00	1.60	1.26	1.60	1.26	1.25	1.25
1601-12-16-16	3/4-14	1-11 1/2	1-11 1/2	2.19	1.77	1.40	1.77	1.40	1.50	1.50
1601-16-12-12	1-11 1/2	3/4-14	3/4-14	2.38	1.72	1.39	1.72	1.39	1.25	1.25
1601-16-16-16	1-11 1/2	1-11 1/2	1-11 1/2	2.38	1.77	1.40	1.77	1.40	1.50	1.50
1601-20-20-20	1 1/4-11 1/2	1 1/4-11 1/2	1 1/4-11 1/2	2.63	2.09	1.67	2.09	1.67	1.88	1.88
1601-24-24-24	1 1/2-11 1/2	1 1/2-11 1/2	1 1/2-11 1/2	2.81	2.19	1.76	2.19	1.76	2.13	2.13

PART NO	C1	D2	D (2)	D (3)
1601-02-02-02	0.56	0.19	0.13	0.13
1601-04-04-04	0.69	0.28	0.22	0.22
1601-04-06-06	0.88	0.28	0.33	0.33
1601-06-04-04	0.88	0.41	0.22	0.22
1601-06-06-06	0.88	0.41	0.33	0.33
1601-08-04-04	1.00	0.53	0.22	0.22
1601-08-06-06	1.00	0.53	0.33	0.33
1601-08-08-08	1.00	0.53	0.45	0.45
1601-08-12-12	1.25	0.53	0.63	0.63
1601-12-08-08	1.25	0.72	0.45	0.45
1601-12-12-12	1.25	0.72	0.63	0.63
1601-12-16-16	1.50	0.72	0.84	0.84
1601-16-12-12	1.50	0.94	0.63	0.63
1601-16-16-16	1.50	0.94	0.84	0.84
1601-20-20-20	1.88	1.25	1.01	1.01
1601-24-24-24	2.13	1.50	1.26	1.26

1602 FEMALE ADAPTER UNION TO FEMALE PIPE BRANCH

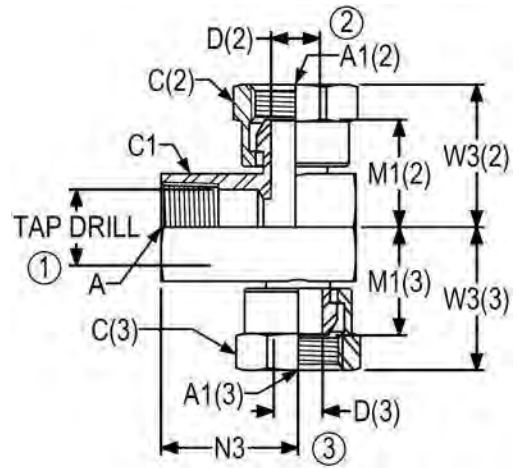

PART NO	A NPTF	A1 (2) NPSM	A1 (3) NPSM	N3	W3 (2)	M1 (2)	W3 (3)	M1 (3)	C (2)	C (3)
1602-02-02-02	1/8-27	1/8-27	1/8-27	0.69	0.85	0.70	0.85	0.70	0.56	0.56
1602-04-04-04	1/4-18	1/4-18	1/4-18	0.94	0.98	0.79	0.98	0.79	0.69	0.69
1602-06-04-04	3/8-18	1/4-18	1/4-18	1.06	1.07	0.88	1.07	0.88	0.69	0.69
1602-06-06-06	3/8-18	3/8-18	3/8-18	1.06	1.20	0.94	1.20	0.94	0.88	0.88
1602-08-06-06	1/2-14	3/8-18	3/8-18	1.25	1.26	1.01	1.26	1.01	0.88	0.88
1602-08-08-08	1/2-14	1/2-14	1/2-14	1.25	1.33	1.00	1.33	1.00	1.00	1.00
1602-12-08-08	3/4-14	1/2-14	1/2-14	1.44	1.45	1.13	1.45	1.13	1.00	1.00
1602-12-12-12	3/4-14	3/4-14	3/4-14	1.44	1.60	1.26	1.60	1.26	1.25	1.25
1602-16-12-12	1-11 1/2	3/4-14	3/4-14	1.75	1.72	1.39	1.72	1.39	1.25	1.25
1602-16-16-16	1-11 1/2	1-11 1/2	1-11 1/2	1.75	1.77	1.40	1.77	1.40	1.50	1.50
1602-20-20-20	1 1/4-11 1/2	1 1/4-11 1/2	1 1/4-11 1/2	2.00	2.09	1.67	2.09	1.67	1.88	1.88

PART NO	C1	TAP DRILL	D (2)	D (3)
1602-02-02-02	0.56	0.33	0.13	0.13
1602-04-04-04	0.69	0.43	0.22	0.22
1602-06-04-04	0.88	0.57	0.22	0.22
1602-06-06-06	0.88	0.57	0.33	0.33
1602-08-06-06	1.00	0.70	0.33	0.33
1602-08-08-08	1.00	0.70	0.45	0.45
1602-12-08-08	1.25	0.91	0.45	0.45
1602-12-12-12	1.25	0.91	0.63	0.63
1602-16-12-12	1.50	1.14	0.63	0.63
1602-16-16-16	1.50	1.14	0.84	0.84
1602-20-20-20	1.88	1.48	1.01	1.01

1603 FEMALE ADAPTER UNION (TRIPLE SWIVEL)

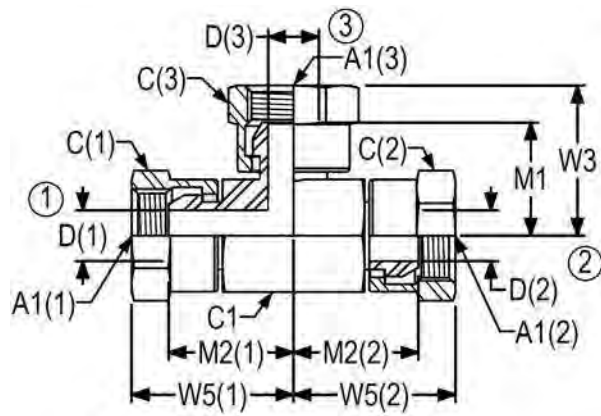

PART NO	A1 (1) NPSM	A1 (2) NPSM	A1 (3) NPSM	W3	M1	W5 (1)	M2 (1)	W5 (2)	M2 (2)
1603-02-02-02	1/8-27	1/8-27	1/8-27	0.85	0.70	0.85	0.70	0.85	0.70
1603-04-04-04	1/4-18	1/4-18	1/4-18	0.98	0.79	1.05	0.86	1.05	0.86
1603-06-06-06	3/8-18	3/8-18	3/8-18	1.20	0.95	1.11	0.86	1.11	0.86
1603-08-08-08	1/2-14	1/2-14	1/2-14	1.33	1.00	1.44	1.11	1.44	1.11
1603-12-12-12	3/4-14	3/4-14	3/4-14	1.60	1.26	1.73	1.39	1.73	1.39
1603-16-16-16	1-11 1/2	1-11 1/2	1-11 1/2	1.77	1.40	1.90	1.53	1.90	1.53
1603-20-20-20	1 1/4-11 1/2	1 1/4-11 1/2	1 1/4-11 1/2	2.09	1.67	2.08	1.66	2.08	1.66

PART NO	C (1)	C (2)	C (3)	C1	D (1)	D (2)	D (3)
1603-02-02-02	0.56	0.56	0.56	0.56	0.13	0.13	0.13
1603-04-04-04	0.69	0.69	0.69	0.69	0.22	0.22	0.22
1603-06-06-06	0.88	0.88	0.88	0.88	0.33	0.33	0.33
1603-08-08-08	1.00	1.00	1.00	1.00	0.45	0.45	0.45
1603-12-12-12	1.25	1.25	1.25	1.25	0.63	0.63	0.63
1603-16-16-16	1.50	1.50	1.50	1.50	0.84	0.84	0.84
1603-20-20-20	1.88	1.88	1.88	1.88	1.01	1.01	1.01

**1604 FEMALE ADAPTER UNION MALE PIPE
RUN CROSS**

INFORMATION AVAILABLE UPON REQUEST.
CALL CUSTOMER SERVICE FOR DETAILS.

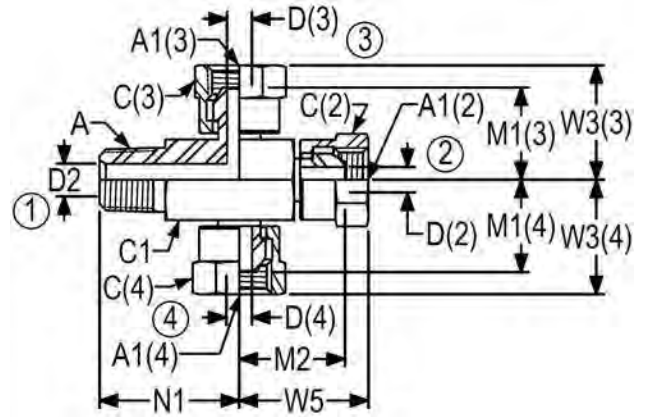

**1605 FEMALE ADAPTER UNION CROSS
(QUAD SWIVEL)**

INFORMATION AVAILABLE UPON REQUEST.
CALL CUSTOMER SERVICE FOR DETAILS.

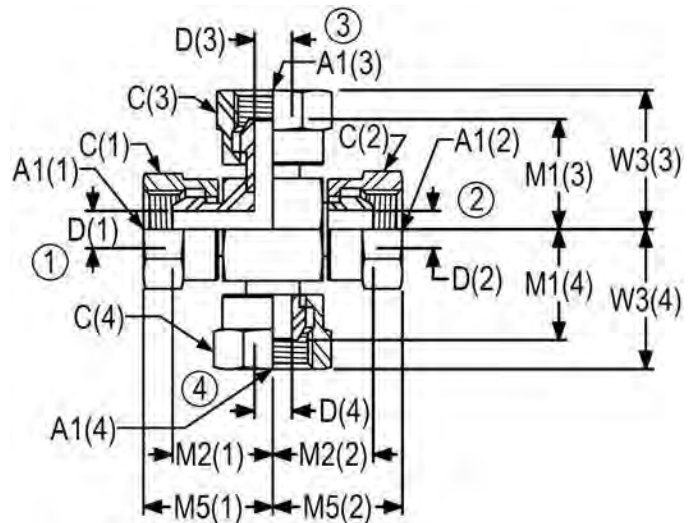

**6900 FEMALE ADAPTER UNION TO
MALE STRAIGHT**
SAE J514 140157

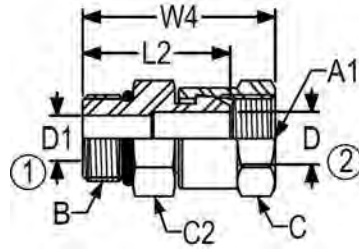

PART NO	B UN/UNF-2A	A1 NPSM	W4	L2	C2	C	D1	D
6900-04-02-O	7/16-20	1/8-27	1.09	0.94	0.56	0.56	0.17	0.13
6900-04-04-O	7/16-20	1/4-18	1.30	1.11	0.56	0.69	0.17	0.22
6900-04-06-O	7/16-20	3/8-18	1.39	1.14	0.69	0.88	0.17	0.33
6900-05-04-O	1/2-20	1/4-18	1.30	1.19	0.63	0.69	0.22	0.22
6900-05-08-O	1/2-20	1/2-14	1.53	1.20	0.88	1.00	0.23	0.45
6900-06-04-O	9/16-18	1/4-18	1.36	1.17	0.69	0.69	0.30	0.22
6900-06-06-O	9/16-18	3/8-18	1.42	1.17	0.69	0.88	0.30	0.33
6900-06-08-O	9/16-18	1/2-14	1.56	1.23	0.88	1.00	0.30	0.45
6900-08-04-O	3/4-16	1/4-18	1.42	1.23	0.88	0.69	0.39	0.22
6900-08-06-O	3/4-16	3/8-18	1.48	1.23	0.88	0.88	0.39	0.33
6900-08-08-O	3/4-16	1/2-14	1.61	1.28	0.88	1.00	0.39	0.45
6900-08-12-O	3/4-16	3/4-14	1.74	1.41	1.00	1.25	0.39	0.63
6900-10-06-O	7/8-14	3/8-18	1.62	1.37	1.00	0.88	0.48	0.33
6900-10-08-O	7/8-14	1/2-14	1.73	1.40	1.00	1.00	0.48	0.45
6900-10-12-O	7/8-14	3/4-14	1.88	1.55	1.00	1.25	0.48	0.48
6900-12-06-O	1 1/16-12	3/8-18	1.78	1.53	1.25	0.88	0.61	0.33
6900-12-08-O	1 1/16-12	1/2-14	1.78	1.45	1.25	1.00	0.61	0.45
6900-12-12-O	1 1/16-12	3/4-14	1.91	1.58	1.25	1.25	0.61	0.63
6900-12-16-O	1 1/16-12	1-11 1/2	2.04	1.66	1.50	1.50	0.61	0.84
6900-14-12-O	1 3/16-12	3/4-14	2.03	1.70	1.38	1.25	0.72	0.63
6900-16-12-O	1 5/16-12	3/4-14	2.06	1.73	1.50	1.25	0.84	0.63
6900-16-16-O	1 5/16-12	1-11 1/2	2.13	1.75	1.50	1.50	0.84	0.84
6900-16-20-O	1 5/16-12	1 1/4-11 1/2	2.32	1.89	1.75	1.88	0.84	1.16
6900-20-12-O	1 5/8-12	3/4-14	2.14	1.81	1.88	1.25	1.08	0.63
6900-20-16-O	1 5/8-12	1-11 1/2	2.20	1.83	1.88	1.50	1.08	0.84
6900-20-20-O	1 5/8-12	1 1/4-11 1/2	2.32	1.89	1.88	1.88	1.08	1.01
6900-24-20-O	1 7/8-12	1 1/4-11 1/2	2.38	1.95	2.13	1.88	1.31	1.16
6900-24-24-O	1 7/8-12	1 1/2-11 1/2	2.37	1.95	2.13	2.13	1.31	1.26
6900-32-32-O	2 1/2-12	2-11 1/2	2.57	2.16	2.75	2.75	1.78	1.72

**6901 90 DEGREE FEMALE ADAPTER
UNION TO ADJ. MALE**
SAE J514 140257

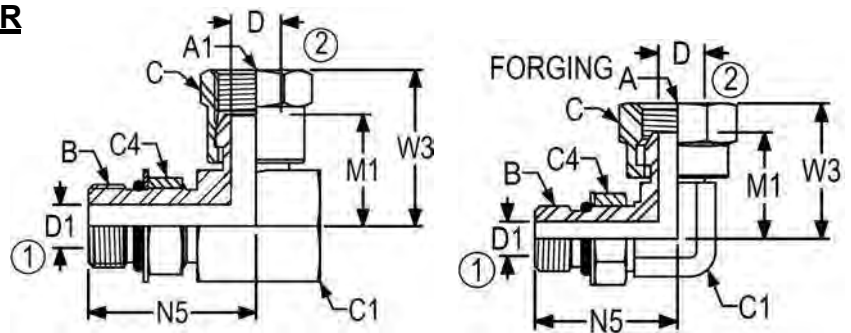

Non forging parts are brazed construction

PART NO	B UN/UNF-2A	A1 NPSM	N5	W3	M1	C	C4	C1	D1	D
6901-02-02-NWO	5/16-24	1/8-27	0.93	0.78	0.64	0.56	0.56	0.44	0.06	0.13
6901-04-02-NWO	7/16-20	1/8-27	1.11	0.91	0.76	0.56	0.56	0.69	0.17	0.13
6901-04-04-NWO	7/16-20	1/4-18	1.11	0.98	0.79	0.69	0.56	0.69	0.17	0.22
6901-04-04-NWO-FG	7/16-20	1/4-18	1.25	1.18	0.94	0.69	0.56	0.50	0.17	0.22
6901-04-06-NWO	7/16-20	3/8-18	1.30	1.20	0.94	0.88	0.56	0.88	0.17	0.33
6901-04-08-NWO	7/16-20	1/2-14	1.28	1.33	1.00	1.00	0.56	1.00	0.17	0.45
6901-06-04-NWO	9/16-18	1/4-18	1.19	0.98	0.79	0.69	0.69	0.69	0.30	0.22
6901-06-04-NWO-FG	9/16-18	1/4-18	1.25	1.18	0.94	0.69	0.69	0.75	0.30	0.22
6901-06-06-NWO	9/16-18	3/8-18	1.22	1.20	0.94	0.88	0.69	0.88	0.30	0.33
6901-06-06-NWO-FG	9/16-18	3/8-18	1.51	1.40	1.12	0.88	0.69	0.75	0.29	0.33
6901-06-08-NWO	9/16-18	1/2-14	1.48	1.33	1.00	1.00	0.69	1.00	0.30	0.45
6901-08-04-NWO	3/4-16	1/4-18	1.52	1.13	0.94	0.69	0.88	1.00	0.39	0.22
6901-08-06-NWO	3/4-16	3/8-18	1.52	1.26	1.01	0.88	0.88	1.00	0.39	0.33
6901-08-06-NWO-FG	3/4-16	3/8-18	1.70	1.50	1.11	0.88	0.88	0.88	0.39	0.33
6901-08-08-NWO	3/4-16	1/2-14	1.52	1.33	1.00	1.00	0.88	1.00	0.39	0.45
6901-08-08-NWO-FG	3/4-16	1/2-14	1.70	1.50	1.11	1.00	0.88	0.88	0.39	0.45
6901-08-12-NWO	3/4-16	3/4-14	1.66	1.60	1.26	1.25	0.88	1.25	0.39	0.63
6901-10-04-NWO	7/8-14	1/4-18	1.64	1.13	0.94	0.69	1.00	1.00	0.48	0.22
6901-10-06-NWO	7/8-14	3/8-18	1.64	1.26	1.01	0.88	1.00	1.00	0.48	0.33
6901-10-08-NWO	7/8-14	1/2-14	1.64	1.33	1.00	1.00	1.00	1.00	0.48	0.45
6901-10-08-NWO-FG	7/8-14	1/2-14	1.70	1.50	1.11	1.00	1.00	1.11	0.48	0.45
6901-10-12-NWO	7/8-14	3/4-14	1.78	1.60	1.26	1.25	1.00	1.25	0.48	0.63
6901-12-06-NWO	1 1/16-12	3/8-18	1.92	1.38	1.13	0.88	1.25	1.25	0.61	0.33
6901-12-08-NWO	1 1/16-12	1/2-14	1.92	1.45	1.13	1.00	1.25	1.25	0.61	0.45
6901-12-12-NWO	1 1/16-12	3/4-14	1.92	1.60	1.26	1.25	1.25	1.25	0.61	0.63
6901-12-16-NWO	1 1/16-12	1-11 1/2	1.97	1.77	1.40	1.50	1.25	1.50	0.61	0.84
6901-14-12-NWO	1 3/16-12	3/4-14	1.92	1.60	1.26	1.25	1.38	1.25	0.72	0.63
6901-14-16-NWO	1 3/16-12	1-11 1/2	2.09	1.77	1.40	1.50	1.38	1.50	0.72	0.84
6901-16-12-NWO	1 5/16-12	3/4-14	2.09	1.72	1.39	1.25	1.50	1.50	0.84	0.63
6901-16-16-NWO	1 5/16-12	1-11 1/2	2.09	1.77	1.40	1.50	1.50	1.50	0.84	0.84
6901-16-20-NWO	1 5/16-12	1 1/4-11 1/2	2.47	2.09	1.67	1.88	1.50	1.88	0.84	1.01
6901-20-12-NWO	1 5/8-12	3/4-14	2.48	1.91	1.58	1.25	1.88	1.88	1.08	0.63
6901-20-16-NWO	1 5/8-12	1-11 1/2	2.48	1.96	1.59	1.50	1.88	1.88	1.08	0.84
6901-20-20-NWO	1 5/8-12	1 1/4-11 1/2	2.48	2.09	1.67	1.88	1.88	1.88	1.08	1.01
6901-24-24-NWO	1 7/8-12	1 1/2-11 1/2	2.61	2.18	1.76	2.13	2.13	2.13	1.31	1.26
6901-32-32-NWO	2 1/2-12	2-11 1/2	3.25	2.50	2.08	2.63	2.75	2.63	1.78	1.72

**6902 45 DEGREE FEMALE ADAPTER
UNION TO ADJ. MALE**
SAE J514 140357

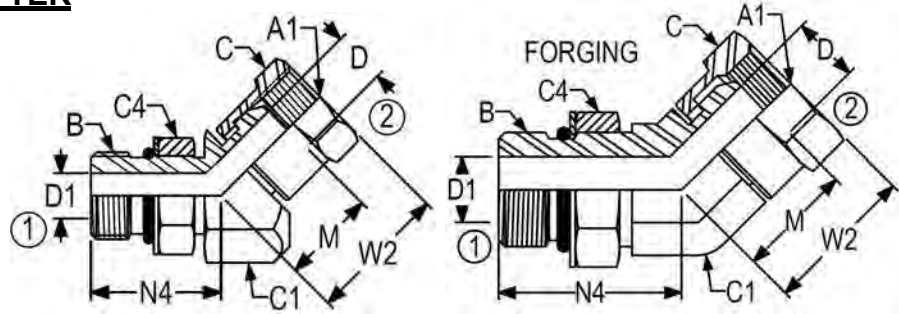

PART NO	B UN/UNF-2A	A1 NPSM	N4	W2	M	C	C4	C1	D1	D
6902-04-04-NWO	7/16-20	1/4-18	1.06	0.85	0.66	0.69	0.56	0.69	0.17	0.22
6902-04-06-NWO	7/16-20	3/8-18	1.06	0.96	0.71	0.88	0.69	0.88	0.17	0.33
6902-06-04-NWO	9/16-18	1/4-18	1.06	0.85	0.66	0.69	0.69	0.88	0.30	0.22
6902-06-06-NWO	9/16-18	3/8-18	1.06	0.96	0.71	0.88	0.69	0.88	0.30	0.33
6902-06-08-NWO	9/16-18	1/2-14	1.06	1.12	0.79	1.00	0.69	1.00	0.30	0.45
6902-08-04-NWO	3/4-16	1/4-18	1.13	1.03	0.84	0.69	0.88	1.00	0.39	0.22
6902-08-06-NWO	3/4-16	3/8-18	1.13	1.13	0.88	0.88	0.88	1.00	0.39	0.33
6902-08-08-NWO	3/4-16	1/2-14	1.13	1.14	0.81	1.00	0.88	1.00	0.39	0.45
6902-08-12-NWO	3/4-16	3/4-14	1.22	1.38	1.05	1.25	0.88	1.25	0.39	0.63
6902-10-06-NWO	7/8-14	3/8-18	1.50	1.07	0.82	0.88	1.00	1.00	0.48	0.33
6902-10-08-NWO	7/8-14	1/2-14	1.50	1.11	0.78	1.00	1.00	1.00	0.48	0.45
6902-10-12-NWO	7/8-14	3/4-14	1.36	1.38	1.05	1.25	1.00	1.25	0.48	0.63
6902-12-08-NWO	1 1/16-12	1/2-14	1.50	1.33	1.00	1.00	1.25	1.25	0.61	0.45
6902-12-12-NWO	1 1/16-12	3/4-14	1.50	1.39	1.06	1.25	1.25	1.25	0.61	0.63
6902-12-12-NWO-FG	1 1/16-12	3/4-14	1.73	1.39	1.06	1.25	1.25	1.06	0.61	0.63
6902-12-16-NWO	1 1/16-12	1-11 1/2	1.53	1.52	1.14	1.50	1.25	1.50	0.61	0.84
6902-16-12-NWO	1 5/16-12	3/4-14	1.63	1.53	1.20	1.25	1.50	1.50	0.84	0.63
6902-16-16-NWO	1 5/16-12	1-11 1/2	1.63	1.52	1.14	1.50	1.50	1.50	0.84	0.84
6902-16-20-NWO	1 5/16-12	1 1/4-11 1/2	1.81	1.61	1.18	1.88	1.50	1.88	0.84	1.01
6902-20-16-NWO	1 5/8-12	1-11 1/2	1.81	1.79	1.42	1.50	1.88	1.88	1.08	0.84
6902-20-20-NWO	1 5/8-12	1 1/4-11 1/2	1.81	1.74	1.31	1.88	1.88	1.88	1.08	1.01
6902-24-24-NWO	1 7/8-12	1 1/2-11 1/2	2.28	1.77	1.34	2.13	2.13	2.13	1.31	1.26
6902-32-32-NWO	2 1/2-12	2-11 1/2	2.00	1.91	1.50	2.63	2.63	2.63	1.78	1.72

Features. NPTF Pipe Fittings

NPTF pipe fittings described in this section include fittings with NPTF male or female pipe ends. Pipe thread connections are used in a wide variety of applications and provide reliable metal to metal sealing. Because of the tapered NPTF thread design, pipe thread connections are not recommended for applications that require repeated re-assembly or precise orientation of the fitting after tightening.

For connections between male or female NPTF pipe ends and 37 degree tube ends, refer to the Tube Fittings Section. For connections between male/female NPTF pipe ends and SAE O-Ring Ports, refer to the Adjustable and O-Ring Fittings Section. For connections between NPTF male pipe ends and Female NPSM Swivels, refer to the Adapter Union Section.

Performance

Where applicable, fittings are designed and qualified to the requirements of SAE J514. Beaded hose stem ends conform to SAE J1231 and are intended for suction or low pressure lines, typically less than 300 psi.

Construction

Unless otherwise specified, fittings are machined from cold drawn carbon steel barstock and forgings. Standard plating is electrodeposited zinc with a clear trivalent chromate conversion coating in accordance with ASTM B633 (Type V SC2). The minimum salt spray resistance is 240 hours to red corrosion when tested in accordance with ASTM B117

Threads

NPTF Threads: Male and female pipe threads conform to the Dryseal American Standard Taper Pipe Thread (SAE J476a, NPTF) Series which will provide pressure tight joints without the use of a lubricant or sealer. Use of these fittings with non-dryseal NPT pipe or hose ends is not recommended for high-pressure applications.

Note: Where not functionally objectionable, use of a compatible lubricant/sealant is recommended for either NPT or NPTF threads to minimize the possibility of galling in assembly.

Assembly Information

For assembly instructions, refer to the Technical Data Section for the appropriate fitting end. Also, refer to the Technical Data Section for recommendations regarding tubing pressure ratings, tube flares and hose/tube routing information. Please note the following:

Tubing for single flare tube ends should be either seamless or welded and drawn, fully annealed tubing per SAE J524 or J525. For double flaring, tubing per SAE J356, J524, J525 or J526 may be used.

In the design and fabrication of tubing or hose runs for any hydraulic system, precautions should be taken to allow for sufficient adjustment of the hose or tubing so that proper alignment can be attained at the fitting connections. Improper fit-up or misalignment should be corrected before final connections are made. Location of fitting connections should be planned to maximize accessibility. Whenever possible, use a torque wrench to tighten connections to the recommended torque.

Ordering Information



Size of fittings are indicated by dash number relating to sixteenths of an inch for the nominal O.D. of the pipe size used. Example: 1/2 inch pipe = 8/16 or (-8) size.

Order standard fittings from appropriate chart indicating required dash numbers. For example, 5502-08-08 is 1/2" male pipe thread to 1/2" female pipe thread. Jump size 5502-08-06 is 1/2" male pipe thread to 3/8" female pipe thread. Pictorial views for each fitting style indicate the correct numbering sequence for fitting ends.

If information is needed for jump sizes not shown, please contact customer service for engineering assistance.

Table JP1. Pressure Ratings for Fittings With NPTF Pipe Threads				
Nominal Pipe Size		Thread Size	Working Pressures	
Nom SAE Dash Size	Nom Inch Pipe O.D.	Dryseal Pipe Thread (NPTF ¹) Male and Female	Fittings With NPTF Pipe Threads	
			MPa	psi
-02	1/8	1/8-27	34.5	5,000
-04	1/4	1/4-18	27.5	4,000
-06	3/8	3/8-18	21	3,000
-08	1/2	1/2-14	21	3,000
-12	3/4	3/4-14	17	2,500
-16	1	1-11-1/2	14	2,000
-20	1 1/4	1-1/4-11-1/2	8	1,150
-24	1 1/2	1-1/2-11-1/2	7	1,000
-32	2	2-11-1/2	7	1,000

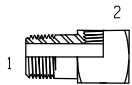
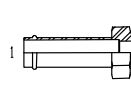
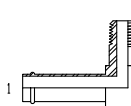
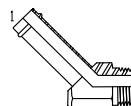
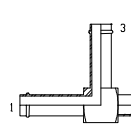
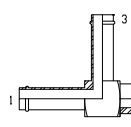
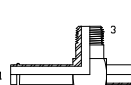
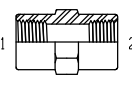
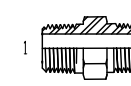
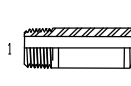
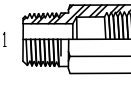
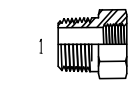
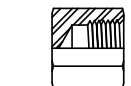
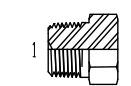
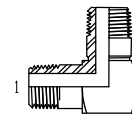
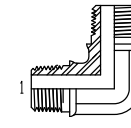
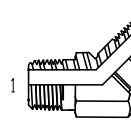
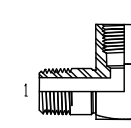
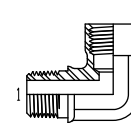
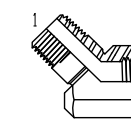
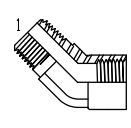
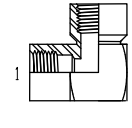
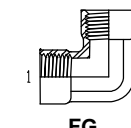
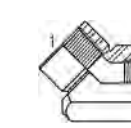
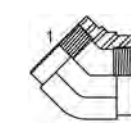
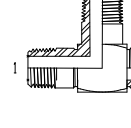
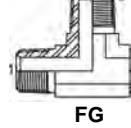
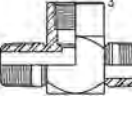
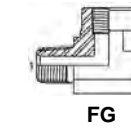
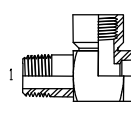
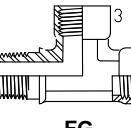
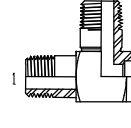
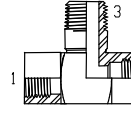
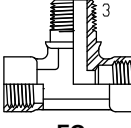
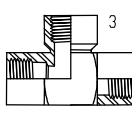
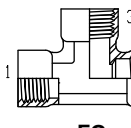
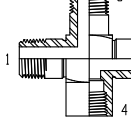
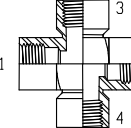
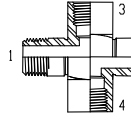
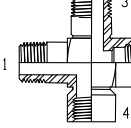
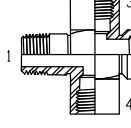
1) Dryseal American Standard Taper Pipe Thread

 <p>3051- (1) Male Pipe (2) Female Pipe</p>	<p>(430160)</p>  <p>4404- (1) Beaded (2) Male Pipe</p>	<p>(430260)</p>  <p>4501- (1) Beaded (2) Male Pipe</p>	<p>(430360)</p>  <p>4503- (1) Beaded (2) Male Pipe</p>	 <p>4504- (1,2&3) Beaded</p>	 <p>4505- (1&3) Beaded (2) Male Pipe</p>	 <p>4506- (1&2) Beaded (3) Male Pipe</p>
<p>(140138)</p>  <p>5000- (1&2) Female Pipe</p>	<p>(140137)</p>  <p>5404- (1&2) Male Pipe</p>	 <p>5404-N- (1&2) Male Pipe</p>	<p>(140139)</p>  <p>5405- (1) Male Pipe (2) Female Pipe</p>	<p>(140140)</p>  <p>5406- (1) Male Pipe (2) Female Pipe</p>	 <p>5406-C- (1) Female Pipe</p>	<p>(130109E)</p>  <p>5406-P- (1) Male Pipe</p>
 <p>5500- (1&2) Male Pipe</p>	 <p>5501- (1&2) Male Pipe</p>	 <p>5501- (1&2) Male Pipe</p>	 <p>5502- (1) Male Pipe (2) Female Pipe</p>	<p>(140239)</p>  <p>5502- (1) Male Pipe (2) Female Pipe</p>	 <p>5503- (1) Male Pipe (2) Female Pipe</p>	<p>(140339)</p>  <p>5503- (1) Male Pipe (2) Female Pipe</p>
<p>(140238)</p>  <p>5504- (1&2) Female Pipe</p>	 <p>5504- (1&2) Female Pipe</p>	 <p>5505- (1&2) Female Pipe</p>	<p>(140338)</p>  <p>5505- (1&2) Female Pipe</p>	 <p>5600- (1,2&3) Male Pipe</p>	 <p>5600- (1,2&3) Male Pipe</p>	
 <p>5601- (1&2) Male Pipe (3) Female Pipe</p>	 <p>5601- (1&2) Male Pipe (3) Female Pipe</p>	 <p>5602- (1) Male Pipe (2&3) Female Pipe</p>	<p>(140424)</p>  <p>5602- (1) Male Pipe (2&3) Female Pipe</p>	 <p>5603- (1&3) Male Pipe (2) Female Pipe</p>	 <p>5604- (1&2) Female Pipe (3) Male Pipe</p>	<p>(140425)</p>  <p>5604- (1&2) Female Pipe (3) Male Pipe</p>
<p>(140438)</p>  <p>5605- (1,2&3) Female Pipe</p>	 <p>5605- (1,2&3) Female Pipe</p>	 <p>5651- (1,2&3) Male Pipe (4) Female Pipe</p>	 <p>5652- (1,2,3&4) Female Pipe</p>	 <p>5653- (1&2) Male Pipe (3&4) Female Pipe</p>	 <p>5654- (1&3) Male Pipe (2&4) Female Pipe</p>	 <p>5655- (1) Male Pipe (2,3&4) Female Pipe</p>
 <p>Long Allen Plug- (1) Male Pipe</p>						

3051 90 DEGREE SHORT STREET ELBOW

PRESSURE RATINGS ON TABLE JP1 DO NOT APPLY.

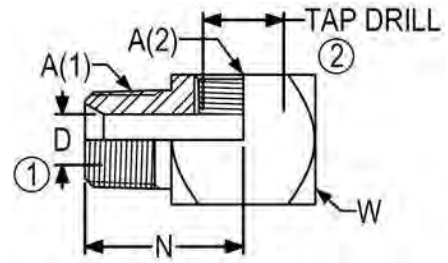

PART NO	A (1) NPTF	A (2) NPTF	N	W	D	TAP DRILL
3051-02-02	1/8-27	1/8-27	0.66	0.56	0.19	0.33
3051-02-02-SHORT	1/8-27	1/8-27	0.55	0.50	0.19	0.33
3051-04-04	1/4-18	1/4-18	1.06	0.88	0.25	0.43
3051-06-06	3/8-18	3/8-18	1.06	0.88	0.31	0.57
3051-08-08	1/2-14	1/2-14	1.38	1.13	0.44	0.70
3051-12-12	3/4-14	3/4-14	1.50	1.38	0.56	0.91
3051-16-16	1-11 1/2	1-11 1/2	1.75	1.63	0.61	1.14

4404 MALE PIPE THREAD HOSE CONNECTOR

SAE J1231 430160

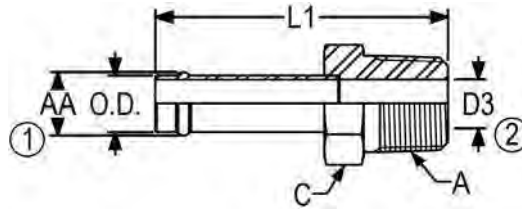

PART NO	TUBE OD	A NPTF	L1	C	AA	D3
4404-04-02	1/4	1/8-27	2.08	0.44	0.29	0.19
4404-04-04	1/4	1/4-18	2.35	0.56	0.29	0.21
4404-04-06	1/4	3/8-18	2.35	0.75	0.29	0.21
4404-05-02	5/16	1/8-27	2.08	0.44	0.36	0.19
4404-05-04	5/16	1/4-18	2.35	0.56	0.36	0.26
4404-05-06	5/16	3/8-18	2.35	0.75	0.36	0.26
4404-06-02	3/8	1/8-27	2.13	0.63	0.43	0.19
4404-06-04	3/8	1/4-18	2.35	0.63	0.43	0.33
4404-06-06	3/8	3/8-18	2.35	0.75	0.43	0.33
4404-06-08	3/4	1/2-14	2.60	0.94	0.43	0.53
4404-08-06	1/2	3/8-18	2.35	0.75	0.56	0.41
4404-08-08	1/2	1/2-14	2.60	0.94	0.56	0.43
4404-08-12	1/2	3/4-14	2.67	1.13	0.56	0.43
4404-10-04	5/8	1/4-18	2.35	0.75	0.69	0.28
4404-10-06	5/8	3/8-18	2.35	0.75	0.69	0.41
4404-10-08	5/8	1/2-14	2.60	0.94	0.69	0.53
4404-10-12	5/8	3/4-14	2.67	1.13	0.69	0.56
4404-10-16	5/8	1-11 1/2	2.86	1.38	0.69	0.56
4404-12-06	3/4	3/8-18	2.35	0.94	0.82	0.41
4404-12-08	3/4	1/2-14	2.60	0.94	0.82	0.53
4404-12-12	3/4	3/4-14	2.67	1.13	0.82	0.69
4404-12-16	3/4	1-11 1/2	2.86	1.38	0.82	0.69
4404-16-08	1	1/2-14	2.63	1.25	1.06	0.53
4404-16-12	1	3/4-14	2.67	1.25	1.06	0.72
4404-16-16	1	1-11 1/2	2.86	1.38	1.06	0.89
4404-16-24	1	1 1/2-11 1/2	3.07	2.00	1.06	0.88
4404-20-12	1 1/4	3/4-14	2.67	1.38	1.36	0.72
4404-20-16	1 1/4	1-11 1/2	2.86	1.38	1.36	0.94
4404-20-20	1 1/4	1 1/4-11 1/2	2.97	1.75	1.36	1.14
4404-20-24	1 1/4	1 1/2-11 1/2	3.07	2.00	1.14	1.25
4404-22-12	1 3/8	3/4-14	2.67	1.75	1.49	0.72
4404-24-20	1 1/2	1 1/4-11 1/2	2.97	1.75	1.62	1.25
4404-24-24	1 1/2	1 1/2-11 1/2	3.07	2.00	1.62	1.40
4404-28-32	1 3/4	2-11 1/2	2.91	2.50	1.89	1.65
4404-32-32	2	2-11 1/2	3.25	2.50	2.15	1.81

4501 90 DEGREE MALE PIPE HOSE FITTING

SAE J1231 431460

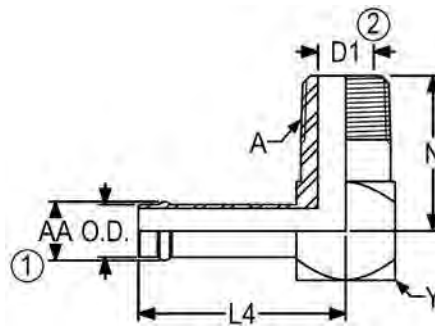

PART NO	TUBE OD	A NPTF	L4	N	Y	AA	D1
4501-04-02	1/4	1/8-27	1.75	0.78	0.50	0.29	0.19
4501-04-04	1/4	1/4-18	1.81	1.09	0.63	0.29	0.28
4501-04-06	1/4	3/8-18	1.91	1.22	0.81	0.29	0.41
4501-05-02	5/16	1/8-27	1.75	0.78	0.50	0.36	0.19
4501-05-04	5/16	1/4-18	1.81	1.09	0.63	0.36	0.28
4501-05-06	5/16	3/8-18	1.91	1.22	0.81	0.36	0.41
4501-06-02	3/8	1/8-27	1.75	0.78	0.50	0.43	0.19
4501-06-04	3/8	1/4-18	1.81	1.09	0.63	0.43	0.28
4501-06-06	3/8	3/8-18	1.91	1.22	0.81	0.43	0.41
4501-06-08	3/8	1/2-14	1.97	1.47	0.94	0.43	0.53
4501-08-04	1/2	1/4-18	1.81	1.09	0.63	0.56	0.28
4501-08-06	1/2	3/8-18	1.91	1.22	0.81	0.56	0.41
4501-08-08	1/2	1/2-14	1.97	1.47	0.94	0.56	0.53
4501-08-12	1/2	3/4-14	2.06	1.59	1.13	0.56	0.72
4501-10-04	5/8	1/4-18	1.97	1.25	0.94	0.69	0.28
4501-10-06	5/8	3/8-18	1.91	1.22	0.81	0.69	0.41
4501-10-08	5/8	1/2-14	1.97	1.47	0.94	0.69	0.53
4501-10-12	5/8	3/4-14	2.06	1.59	1.13	0.69	0.72
4501-10-16	5/8	1-11 1/2	2.19	1.97	1.38	0.69	0.94
4501-12-06	3/4	3/8-18	1.91	1.22	0.81	0.82	0.41
4501-12-08	3/4	1/2-14	1.97	1.47	0.94	0.82	0.53
4501-12-12	3/4	3/4-14	2.06	1.59	1.13	0.82	0.72
4501-12-16	3/4	1-11 1/2	2.19	1.97	1.38	0.82	0.94
4501-16-08	1	1/2-14	2.19	1.69	1.38	1.06	0.53
4501-16-12	1	3/4-14	2.06	1.59	1.13	1.06	0.72
4501-16-16	1	1-11 1/2	2.19	1.97	1.38	1.06	0.94
4501-16-20	1	1 1/4-11 1/2	2.38	2.38	1.75	1.06	1.25
4501-20-12	1 1/4	3/4-14	2.19	1.72	1.38	1.36	0.72
4501-20-16	1 1/4	1-11 1/2	2.19	1.97	1.38	1.36	0.94
4501-20-20	1 1/4	1 1/4-11 1/2	2.38	2.38	1.75	1.36	1.25
4501-20-24	1 1/4	1 1/2-11 1/2	2.50	2.64	2.00	1.36	1.50
4501-24-16	1 1/2	1-11 1/2	2.38	2.16	1.75	1.62	0.94
4501-24-20	1 1/2	1 1/4-11 1/2	2.38	2.38	1.75	1.62	1.25
4501-24-24	1 1/2	1 1/2-11 1/2	2.50	2.64	2.00	1.62	1.50
4501-32-32	2	2-11 1/2	2.81	3.00	2.63	2.15	1.94

4503 45 DEGREE MALE PIPE HOSE FITTING

SAE J1231 430360

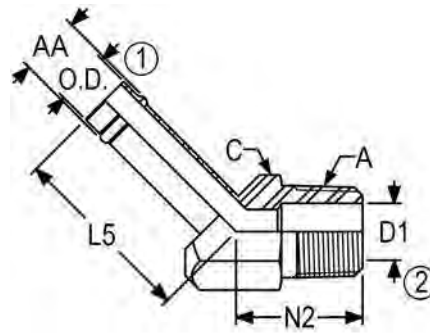

PART NO	TUBE OD	A NPTF	L5	N2	C	AA	D1
4503-04-02	1/4	1/8-27	1.68	0.64	0.50	0.29	0.19
4503-04-04	1/4	1/4-18	1.70	0.86	0.63	0.29	0.28
4503-05-02	5/16	1/8-27	1.63	0.64	0.50	0.36	0.19
4503-05-04	5/16	1/4-18	1.70	0.86	0.63	0.36	0.30
4503-06-04	3/8	1/4-18	1.67	0.86	0.63	0.43	0.30
4503-06-06	3/8	3/8-18	1.69	0.95	0.81	0.43	0.41
4503-08-04	1/2	1/4-18	1.62	0.86	0.63	0.56	0.30
4503-08-06	1/2	3/8-18	1.74	0.95	0.81	0.56	0.41
4503-08-08	1/2	1/2-14	1.72	1.17	0.94	0.56	0.53
4503-10-06	5/8	3/8-18	1.67	0.95	0.81	0.69	0.41
4503-10-08	5/8	1/2-14	1.75	1.17	0.94	0.69	0.53
4503-10-12	5/8	3/4-14	1.81	1.20	1.13	0.69	0.64
4503-12-06	3/4	3/8-18	1.69	0.95	0.81	0.82	0.41
4503-12-08	3/4	1/2-14	1.72	1.17	0.94	0.82	0.53
4503-12-12	3/4	3/4-14	1.78	1.20	1.13	0.82	0.64
4503-12-16	3/4	1-11 1/2	2.03	1.48	1.38	0.82	0.94
4503-16-12	1	3/4-14	1.75	1.75	1.13	1.06	0.64
4503-16-16	1	1-11 1/2	1.85	1.48	1.38	1.06	0.94
4503-16-20	1	1 1/4-11 1/2	2.06	1.67	1.75	1.06	1.25
4503-20-16	1 1/4	1-11 1/2	1.78	1.48	1.38	1.36	0.94
4503-20-20	1 1/4	1 1/4-11 1/2	1.91	1.67	1.75	1.36	1.25
4503-24-20	1 1/2	1 1/4-11 1/2	1.84	1.67	1.75	1.62	1.25
4503-24-24	1 1/2	1 1/2-11 1/2	1.95	1.77	2.00	1.62	1.34
4503-32-32	2	2-11 1/2	2.20	2.11	2.50	2.15	1.94

4504 BEADED HOSE FITTING TEE

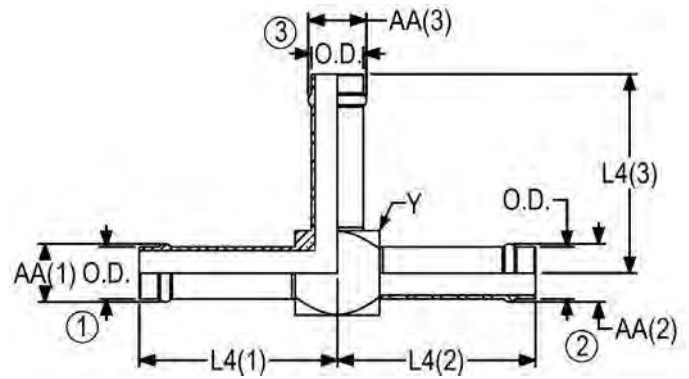

PART NO	TUBE OD	L4 (1)	L4 (2)	L4 (3)	Y	AA (1)	AA (2)	AA (3)
4504-04-04-04	1/4-1/4-1/4	1.75	1.75	1.75	0.50	0.29	0.29	0.29
4504-06-06-04	3/8-3/8-1/4	1.81	1.81	1.81	0.63	0.43	0.43	0.29
4504-06-06-06	3/8-3/8-3/8	1.80	1.80	1.75	0.50	0.43	0.43	0.43
4504-06-06-08	3/8-3/8-1/2	2.00	2.00	2.00	1.00	0.43	0.43	0.56
4504-06-06-10	3/8-3/8-5/8	1.97	1.97	1.97	0.94	0.43	0.43	0.69
4504-08-05-05	1/2-5/16-5/16	1.91	1.91	1.91	0.81	0.56	0.36	0.36
4504-08-06-06	1/2-3/8-3/8	1.91	1.91	1.91	0.81	0.56	0.43	0.43
4504-08-06-08	1/2-3/8-1/2	1.91	1.91	1.91	0.81	0.56	0.43	0.56
4504-08-08-04	1/2-1/2-1/4	1.81	1.81	1.91	0.63	0.56	0.56	0.29
4504-08-08-08	1/2-1/2-1/2	1.91	1.91	1.91	0.81	0.56	0.56	0.56
4504-10-10-04	5/8-5/8-1/4	1.91	1.91	1.97	0.81	0.69	0.69	0.29
4504-10-10-06	5/8-5/8-3/8	1.91	1.91	1.97	0.81	0.69	0.69	0.43
4504-10-10-10	5/8-5/8-5/8	1.97	1.97	1.97	0.94	0.69	0.69	0.69
4504-10-10-12	5/8-5/8-3/4	2.00	2.00	2.00	1.00	0.69	0.69	0.82
4504-12-08-12	3/4-1/2-3/4	2.00	2.00	2.00	1.00	0.82	0.56	0.82
4504-12-12-08	3/4-3/4-1/2	2.06	2.06	2.06	1.13	0.82	0.82	0.56
4504-12-12-10	3/4-3/4-5/8	2.06	2.06	2.06	1.13	0.82	0.82	0.69
4504-12-12-12	3/4-3/4-3/4	2.00	2.00	2.00	1.00	0.82	0.82	0.82
4504-16-12-16	1-3/4-1	2.19	2.19	2.19	1.38	1.06	0.82	1.06
4504-16-16-04	1-1-1/4	2.19	2.19	2.19	1.38	1.06	1.06	0.29
4504-16-16-12	1-1-3/4	2.19	2.19	2.19	1.38	1.06	1.06	0.82
4504-16-16-16	1-1-1	2.19	2.19	2.19	1.38	1.06	1.06	1.06
4504-20-16-16	1 1/4-1-1	2.31	2.31	2.31	1.63	1.25	1.00	1.00
4504-20-16-20	1 1/4-1-1 1/4	2.31	2.31	2.31	1.63	1.25	1.00	1.25
4504-20-20-12	1 1/4-1 1/4-3/4	2.31	2.31	2.31	1.63	1.25	1.25	0.75

4505 MALE PIPE RUN HOSE FITTING TEE

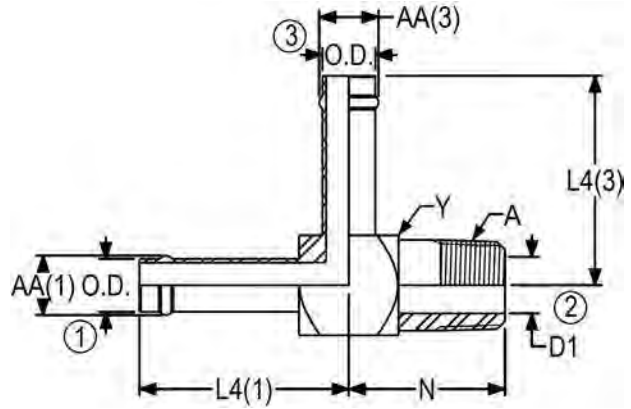

PART NO	TUBE OD	A NPTF	L4 (1)	N	L4 (3)	Y	AA (1)	D1	AA (3)
4505-08-08-08	1/2-1/2	1/2-14	1.97	1.47	1.97	0.94	0.56	0.53	0.56
4505-12-12-12	3/4-3/4	3/4-14	2.06	1.59	2.06	1.13	0.82	0.72	0.82
4505-16-16-12	1-3/4	1-11 1/2	2.19	1.97	2.19	1.38	1.06	0.94	0.82
4505-16-16-16	1-1	1-11 1/2	2.19	1.97	2.19	1.38	1.06	0.94	1.06

4506 MALE PIPE BRANCH HOSE FITTING TEE

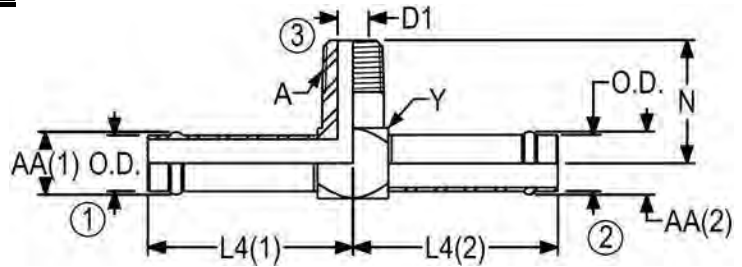

PART NO	TUBE OD	A NPTF	L4 (1)	L4 (2)	N	Y	AA (1)	AA (2)	D1
4506-08-08-04	1/2-1/2	1/4-18	1.81	1.81	1.09	0.63	0.50	0.50	0.28
4506-08-08-06	1/2-1/2	3/8-18	1.91	1.91	1.22	0.81	0.56	0.56	0.41
4506-10-10-08	5/8-5/8	1/2-14	1.97	1.97	1.47	0.94	0.63	0.63	0.53

5000 HEXAGON PIPE COUPLING

SAE J514 140138

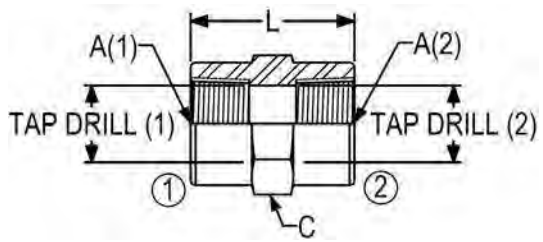

PART NO	A (1) NPTF	A (2) NPTF	L	C	TAP DRILL (1)	TAP DRILL (2)
5000-02-02	1/8-27	1/8-27	0.75	0.63	0.33	0.33
5000-04-02	1/4-18	1/8-27	1.13	0.75	0.43	0.33
5000-04-04	1/4-18	1/4-18	1.13	0.75	0.43	0.43
5000-06-04	3/8-18	1/4-18	1.13	0.88	0.57	0.43
5000-06-06	3/8-18	3/8-18	1.13	0.88	0.57	0.57
5000-08-02	1/2-14	1/8-27	1.50	1.13	0.70	0.33
5000-08-04	1/2-14	1/4-18	1.50	1.13	0.70	0.43
5000-08-06	1/2-14	3/8-18	1.50	1.13	0.70	0.57
5000-08-08	1/2-14	1/2-14	1.50	1.13	0.70	0.70
5000-12-06	3/4-14	3/8-18	1.53	1.38	0.91	0.57
5000-12-08	3/4-14	1/2-14	1.53	1.38	0.91	0.70
5000-12-12	3/4-14	3/4-14	1.53	1.38	0.91	0.91
5000-16-12	1-11 1/2	3/4-14	1.89	1.63	1.14	0.91
5000-16-16	1-11 1/2	1-11 1/2	1.89	1.63	1.14	1.14
5000-20-12	1 1/4-11 1/2	3/4-14	2.08	2.00	1.48	0.91
5000-20-16	1 1/4-11 1/2	1-11 1/2	1.93	2.00	1.48	1.14
5000-20-20	1 1/4-11 1/2	1 1/4-11 1/2	1.93	2.00	1.48	1.48
5000-24-24	1 1/2-11 1/2	1 1/2-11 1/2	1.93	2.38	1.72	1.72
5000-32-32	2-11 1/2	2-11 1/2	1.96	2.88	2.19	2.19
5000-40-40	2 1/2-8	2 1/2-8	2.67	3.50	2.64	2.64

5404 HEXAGON PIPE NIPPLE

SAE J514 140137

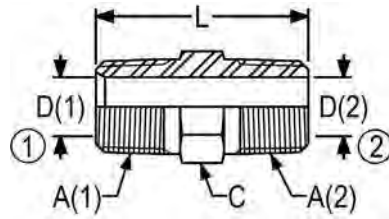

PART NO	A (1) NPTF	A (2) NPTF	L	C	D (1)	D (2)
5404-02-02	1/8-27	1/8-27	1.06	0.44	0.19	0.19
5404-04-02	1/4-18	1/8-27	1.26	0.63	0.28	0.19
5404-04-04	1/4-18	1/4-18	1.45	0.63	0.28	0.28
5404-06-02	3/8-18	1/8-27	1.26	0.75	0.41	0.19
5404-06-04	3/8-18	1/4-18	1.45	0.75	0.41	0.28
5404-06-06	3/8-18	3/8-18	1.45	0.75	0.41	0.41
5404-08-04	1/2-14	1/4-18	1.70	0.88	0.53	0.28
5404-08-06	1/2-14	3/8-18	1.70	0.88	0.53	0.41
5404-08-08	1/2-14	1/2-14	1.89	0.88	0.53	0.53
5404-12-04	3/4-14	1/4-18	1.77	1.13	0.72	0.28
5404-12-06	3/4-14	3/8-18	1.77	1.13	0.72	0.41
5404-12-08	3/4-14	1/2-14	1.96	1.13	0.72	0.53
5404-12-12	3/4-14	3/4-14	1.96	1.13	0.72	0.72
5404-16-06	1-11 1/2	3/8-18	1.96	1.38	0.94	0.41
5404-16-08	1-11 1/2	1/2-14	2.15	1.38	0.94	0.53
5404-16-12	1-11 1/2	3/4-14	2.15	1.38	0.94	0.72
5404-16-16	1-11 1/2	1-11 1/2	2.34	1.38	0.94	0.94
5404-20-08	1 1/4-11 1/2	1/2-14	2.26	1.75	1.25	0.53
5404-20-12	1 1/4-11 1/2	3/4-14	2.26	1.75	1.25	0.72
5404-20-16	1 1/4-11 1/2	1-11 1/2	2.45	1.75	1.25	0.94
5404-20-20	1 1/4-11 1/2	1 1/4-11 1/2	2.48	1.75	1.25	1.25
5404-24-12	1 1/2-11 1/2	3/4-14	2.36	2.00	1.50	0.72
5404-24-16	1 1/2-11 1/2	1-11 1/2	2.55	2.00	1.50	0.94
5404-24-20	1 1/2-11 1/2	1 1/4-11 1/2	2.58	2.00	1.50	1.25
5404-24-24	1 1/2-11 1/2	1 1/2-11 1/2	2.61	2.00	1.50	1.50
5404-32-12	2-11 1/2	1/2-14	2.54	2.50	1.94	0.72
5404-32-16	2-11 1/2	1-11 1/2	2.63	2.50	1.78	0.94
5404-32-20	1 1/4-11 1/2	2-11 1/2	2.76	2.50	1.13	1.78
5404-32-24	2-11 1/2	1 1/2-11 1/2	2.79	2.50	1.94	1.50
5404-32-32	2-11 1/2	2-11 1/2	2.82	2.50	1.94	1.94

5404-N STRAIGHT PIPE NIPPLE

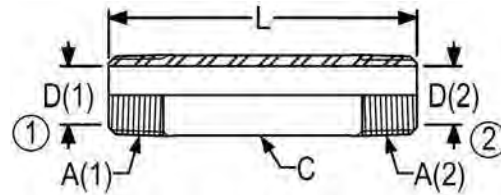

PART NO	A (1) NPTF	A (2) NPTF	L	C	D (1)	D (2)
5404-N-02-02 X 3/4	1/8-27	1/8-27	0.75	0.44	0.17	0.17
5404-N-02-02 X 2	1/8-27	1/8-27	2.00	0.44	0.17	0.17
5404-N-02-02 X 2 1/2	1/8-27	1/8-27	2.50	0.44	0.17	0.17
5404-N-02-02 X 4	1/8-27	1/8-27	4.00	0.44	0.17	0.17
5404-N-04-04 X 7/8	1/4-18	1/4-18	0.88	0.56	0.30	0.30
5404-N-04-04 X 1 1/2	1/4-18	1/4-18	1.50	0.56	0.30	0.30
5404-N-04-04 X 2	1/4-18	1/4-18	2.00	0.56	0.30	0.30
5404-N-04-04 X 2 1/2	1/4-18	1/4-18	2.50	0.56	0.30	0.30
5404-N-04-04 X 3	1/4-18	1/4-18	3.00	0.56	0.30	0.30
5404-N-04-04 X 6	1/4-18	1/4-18	6.00	0.56	0.30	0.30
5404-N-06-06 X 1	3/8-18	3/8-18	1.00	0.69	0.39	0.39
5404-N-06-06 X 1 1/2	3/8-18	3/8-18	1.50	0.69	0.39	0.39
5404-N-06-06 X 2	3/8-18	3/8-18	2.00	0.69	0.39	0.39
5404-N-06-06 X 3	3/8-18	3/8-18	3.00	0.69	0.39	0.39
5404-N-06-06 X 4	3/8-18	3/8-18	4.00	0.69	0.39	0.39
5404-N-06-06 X 6	3/8-18	3/8-18	6.00	0.69	0.39	0.39
5404-N-08-08 X 1 1/8	1/2-14	1/2-14	1.13	0.88	0.48	0.48
5404-N-08-08 X 1 1/2	1/2-14	1/2-14	1.50	0.88	0.48	0.48
5404-N-08-08 X 2	1/2-14	1/2-14	2.00	0.88	0.48	0.48
5404-N-08-08 X 2 1/2	1/2-14	1/2-14	2.50	0.88	0.48	0.48
5404-N-08-08 X 3	1/2-14	1/2-14	3.00	0.88	0.48	0.48
5404-N-08-08 X 3 1/2	1/2-14	1/2-14	3.50	0.88	0.48	0.48
5404-N-08-08 X 4	1/2-14	1/2-14	4.00	0.88	0.48	0.48
5404-N-08-08 X 4 1/2	1/2-14	1/2-14	4.50	0.88	0.48	0.48
5404-N-08-08 X 8 1/2	1/2-14	1/2-14	8.50	0.88	0.48	0.48
5404-N-12-12 X 1 3/8	3/4-14	3/4-14	1.38	1.06	0.61	0.61
5404-N-12-12 X 2	3/4-14	3/4-14	2.00	1.06	0.61	0.61
5404-N-12-12 X 2 1/2	3/4-14	3/4-14	2.50	1.06	0.61	0.61
5404-N-12-12 X 3	3/4-14	3/4-14	3.00	1.06	0.61	0.61
5404-N-12-12 X 4	3/4-14	3/4-14	4.00	1.06	0.61	0.61
5404-N-12-12 X 6	3/4-14	3/4-14	6.00	1.06	0.61	0.61
5404-N-16-16 X 2	1-11 1/2	1-11 1/2	2.00	1.31	0.84	0.84
5404-N-16-16 X 3	1-11 1/2	1-11 1/2	3.00	1.31	0.84	0.84
5404-N-16-16 X 4	1-11 1/2	1-11 1/2	4.00	1.31	0.84	0.84
5404-N-16-16 X 5	1-11 1/2	1-11 1/2	5.00	1.31	0.84	0.84
5404-N-24-24 X 2 1/2	1 1/2-11 1/2	1 1/2-11 1/2	2.50	2.00	1.38	1.38

5405 PIPE ADAPTER

SAE J514 140139

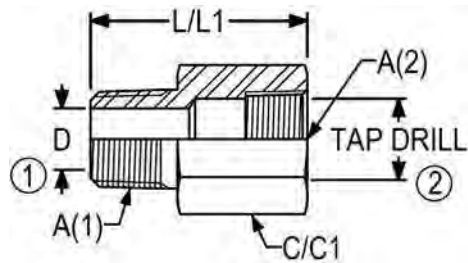

PART NO	A (1) NPTF	A (2) NPTF	L/L1	C/C1	D	TAP DRILL
5405-02-02	1/8-27	1/8-27	1.04	0.63	0.19	0.33
5405-02-04	1/8-27	1/4-18	1.21	0.75	0.19	0.43
5405-02-06	1/8-27	3/8-18	1.26	0.88	0.19	0.57
5405-02-08	1/8-27	1/2-14	1.50	1.13	0.19	0.70
5405-04-02	1/4-18	1/8-27	1.39	0.56	0.28	0.33
5405-04-04	1/4-18	1/4-18	1.39	0.75	0.28	0.43
5405-04-06	1/4-18	3/8-18	1.44	0.88	0.28	0.57
5405-04-08	1/4-18	1/2-14	1.68	1.13	0.28	0.70
5405-06-04	3/8-18	1/4-18	1.44	0.75	0.41	0.57
5405-06-06	3/8-18	3/8-18	1.44	0.88	0.41	0.57
5405-06-08	3/8-18	1/2-14	1.68	1.13	0.41	0.70
5405-06-12	3/8-18	3/4-14	1.74	1.38	0.41	0.91
5405-08-06	1/2-14	3/8-18	1.87	0.88	0.53	0.57
5405-08-08	1/2-14	1/2-14	1.87	1.13	0.53	0.70
5405-08-12	1/2-14	3/4-14	1.93	1.38	0.53	0.91
5405-08-16	1/2-14	1-11 1/2	2.19	1.63	0.53	1.14
5405-12-08	3/4-14	1/2-14	1.93	1.13	0.72	0.70
5405-12-12	3/4-14	3/4-14	1.93	1.38	0.72	0.91
5405-12-16	3/4-14	1-11 1/2	2.18	1.63	0.72	1.14
5405-12-20	3/4-14	1 1/4-11 1/2	2.28	2.00	0.72	1.48
5405-16-08	1-11 1/2	1/2-14	2.37	1.38	0.94	0.70
5405-16-12	1-11 1/2	3/4-14	2.37	1.38	0.94	0.91
5405-16-16	1-11 1/2	1-11 1/2	2.37	1.63	0.94	1.14
5405-16-20	1-11 1/2	1 1/4-11 1/2	2.46	2.00	0.94	1.48
5404-16-24	1-11 1/2	1 1/2-11 1/2	2.47	2.38	0.94	1.72
5405-20-16	1 1/4-11 1/2	1-11 1/2	2.49	1.75	1.25	1.14
5405-20-24	1 1/4-11 1/2	1 1/2-11 1/2	2.50	2.38	1.25	1.72
5405-20-32	1 1/4-11 1/2	2-11 1/2	2.60	2.88	1.25	2.19
5405-24-24	1 1/2-11 1/2	1 1/2-11 1/2	2.53	2.38	1.50	1.72
5405-24-32	1 1/2-11 1/2	2-11 1/2	2.63	2.88	1.50	2.19
5405-32-32	2-11 1/2	2-11 1/2	2.66	2.88	1.94	2.20

5406 PIPE REDUCER BUSHING

SAE J514 140140

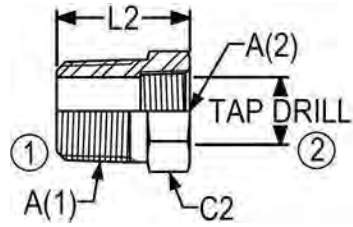

PART NO	A (1) NPTF	A (2) NPTF	L2	C2	TAP DRILL
5406-04-02	1/4-18	1/8-27	0.85	0.63	0.33
5406-06-02	3/8-18	1/8-27	0.85	0.75	0.33
5406-06-04	3/8-18	1/4-18	0.85	0.75	0.43
5406-08-02	1/2-14	1/8-27	1.10	0.88	0.33
5406-08-04	1/2-14	1/4-18	1.10	0.88	0.43
5406-08-06	1/2-14	3/8-18	1.10	0.88	0.57
5406-12-02	3/4-14	1/8-27	1.17	1.13	0.33
5406-12-04	3/4-14	1/4-18	1.17	1.13	0.43
5406-12-06	3/4-14	3/8-18	1.17	1.13	0.57
5406-12-08	3/4-14	1/2-14	1.17	1.13	0.70
5406-16-02	1-11 1/2	1/8-27	1.36	1.38	0.33
5406-16-04	1-11 1/2	1/4-18	1.36	1.38	0.43
5406-16-06	1-11 1/2	3/8-18	1.36	1.38	0.57
5406-16-08	1-11 1/2	1/2-14	1.36	1.38	0.70
5406-16-12	1-11 1/2	3/4-14	1.36	1.38	0.91
5406-20-04	1 1/4-11 1/2	1/4-18	1.47	1.75	0.43
5406-20-06	1 1/4-11 1/2	3/8-18	1.47	1.75	0.57
5406-20-08	1 1/4-11 1/2	1/2-14	1.47	1.75	0.70
5406-20-12	1 1/4-11 1/2	3/4-14	1.47	1.75	0.91
5406-20-16	1 1/4-11 1/2	1-11 1/2	1.47	1.75	1.14
5406-24-04	1 1/2-11 1/2	1/4-18	1.55	2.00	0.43
5406-24-06	1 1/2-11 1/2	3/8-18	1.57	2.00	0.57
5406-24-08	1 1/2-11 1/2	1/2-14	1.57	2.00	0.70
5406-24-12	1 1/2-11 1/2	3/4-14	1.57	2.00	0.91
5406-24-16	1 1/2-11 1/2	1-11 1/2	1.57	2.00	1.14
5406-24-20	1 1/2-11 1/2	1 1/4-11 1/2	1.57	2.00	1.48
5406-32-08	2-11 1/2	1/2-14	1.75	2.50	0.70
5406-32-12	2-11 1/2	3/4-14	1.75	2.50	0.91
5406-32-16	2-11 1/2	1-11 1/2	1.75	2.50	1.14
5406-32-20	2-11 1/2	1 1/4-11 1/2	1.75	2.50	1.48
5406-32-24	2-11 1/2	1 1/2-11 1/2	1.75	2.50	1.72

**5406-C HEAVY DUTY FEMALE
PIPE CAP NUT**

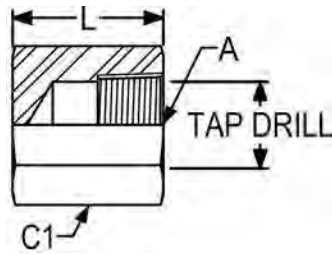

PART NO	A NPTF	L	C1	TAP DRILL
5406-C-02	1/8-27	0.69	0.56	0.33
5406-C-04	1/4-18	0.92	0.75	0.43
5406-C-06	3/8-18	0.97	0.88	0.57
5406-C-08	1/2-14	1.23	1.13	0.70
5406-C-12	3/4-14	1.31	1.38	0.91
5406-C-16	1-11 1/2	1.61	1.63	1.14
5406-C-40	2 1/2-8	1.70	3.50	2.64

5406-P MALE PIPE PLUG
SAE J531 130109E

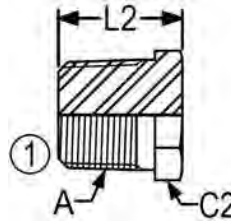

PART NO	A NPTF	L2	C2
5406-02P	1/8-27	0.56	0.44
5406-04P	1/4-18	0.75	0.56
5406-06P	3/8-18	0.78	0.69
5406-08P	1/2-14	0.96	0.88
5406-12P	3/4-14	1.05	1.13
5406-16P	1-11 1/2	1.24	1.38
5406-20P	1 1/4-11 1/2	1.47	1.75
5406-24P	1 1/2-11 1/2	1.57	2.00
5406-32P	2-11 1/2	1.75	2.50

5500 90 DEGREE MALE PIPE ELBOW

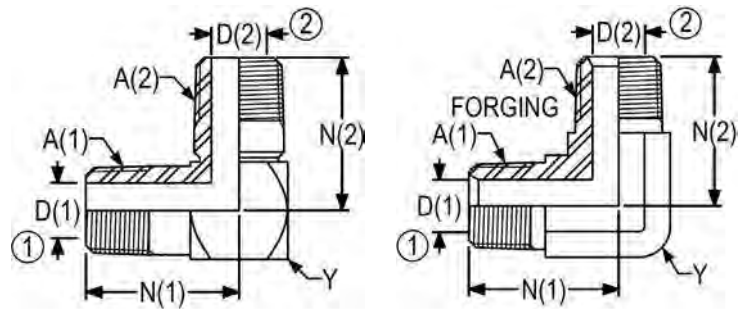

*Non forging parts are brazed construction

PART NO	A (1) NPTF	A (2) NPTF	N (1)	N (2)	Y	D (1)	D (2)
5500-02-02	1/8-27	1/8-27	0.78	0.78	0.50	0.19	0.19
5500-02-02-FG	1/8-27	1/8-27	0.72	0.72	0.44	0.19	0.19
5500-04-02	1/4-18	1/8-27	1.09	0.84	0.63	0.28	0.19
5500-04-02-FG	1/4-18	1/8-27	1.09	0.90	0.56	0.28	0.19
5500-04-04	1/4-18	1/4-18	1.09	1.09	0.63	0.28	0.28
5500-04-04-FG	1/4-18	1/4-18	1.09	1.09	0.56	0.28	0.28
5500-06-04	3/8-18	1/4-18	1.22	1.19	0.81	0.41	0.28
5500-06-04-FG	3/8-18	1/4-18	1.22	1.22	0.75	0.41	0.28
5500-06-06	3/8-18	3/8-18	1.22	1.22	0.81	0.41	0.41
5500-06-06-FG	3/8-18	3/8-18	1.22	1.22	0.75	0.41	0.41
5500-08-04	1/2-14	1/4-18	1.47	1.25	0.94	0.53	0.28
5500-08-06	1/2-14	3/8-18	1.47	1.28	0.94	0.53	0.41
5500-08-06-FG	1/2-14	3/8-18	1.47	1.28	0.88	0.53	0.41
5500-08-08	1/2-14	1/2-14	1.47	1.47	0.94	0.53	0.53
5500-08-08-FG	1/2-14	1/2-14	1.47	1.47	0.88	0.53	0.53
5500-12-04	3/4-14	1/4-18	1.59	1.34	1.13	0.72	0.28
5500-12-08	3/4-14	1/2-14	1.59	1.56	1.13	0.72	0.53
5500-12-08-FG	3/4-14	1/2-14	1.59	1.59	1.06	0.72	0.53
5500-12-12	3/4-14	3/4-14	1.59	1.59	1.13	0.72	0.72
5500-12-12-FG	3/4-14	3/4-14	1.59	1.59	1.06	0.72	0.72
5500-16-12	1-11 1/2	3/4-14	1.97	1.72	1.38	0.94	0.72
5500-16-12-FG	1-11 1/2	3/4-14	1.78	1.97	1.31	0.94	0.72
5500-16-16	1-11 1/2	1-11 1/2	1.97	1.97	1.38	0.94	0.94
5500-16-16-FG	1-11 1/2	1-11 1/2	1.97	1.97	1.31	0.94	0.94
5500-20-16	1 1/4-11 1/2	1-11 1/2	2.38	2.16	1.75	1.25	0.94
5500-20-20	1 1/4-11 1/2	1 1/4-11 1/2	2.38	2.38	1.75	1.25	1.25
5500-20-20-FG	1 1/4-11 1/2	1 1/2-11 1/2	2.38	2.38	1.63	1.25	1.25
5500-24-24	1 1/2-11 1/2	1 1/2-11 1/2	2.64	2.64	2.00	1.50	1.50
5500-32-32	2-11 1/2	2-11 1/2	3.00	3.00	2.63	1.94	1.94

5501 45 DEGREE MALE PIPE ELBOW

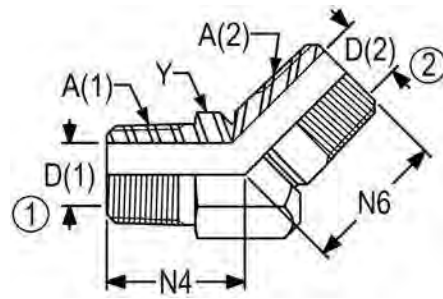

PART NO	A (1) NPTF	A (2) NPTF	N4	N6	Y	D (1)	D (2)
5501-02-02	1/8-27	1/8-27	0.63	0.66	0.50	0.19	0.19
5501-04-04	1/4-18	1/4-18	0.86	0.91	0.63	0.28	0.28
5501-06-06	3/8-18	3/8-18	0.95	1.00	0.81	0.41	0.41
5501-08-08	1/2-14	1/2-14	1.17	1.22	0.94	0.53	0.53
5501-12-04	3/4-14	1/4-18	1.20	1.16	1.13	0.72	0.28
5501-12-12	3/4-14	3/4-14	1.20	1.20	1.13	0.72	0.72
5501-16-16	1-11 1/2	1-11 1/2	1.48	1.63	1.38	0.94	0.94
5501-20-20	1 1/4-11 1/2	1 1/4-11 1/2	1.67	1.70	1.75	1.25	1.25
5501-24-24	1 1/2-11 1/2	1 1/2-11 1/2	1.77	2.02	2.00	1.34	1.34
5501-32-32	2-11 1/2	2-11 1/2	2.11	2.11	2.50	1.94	1.94

5502 90 DEGREE STREET ELBOW

SAE J514 140239

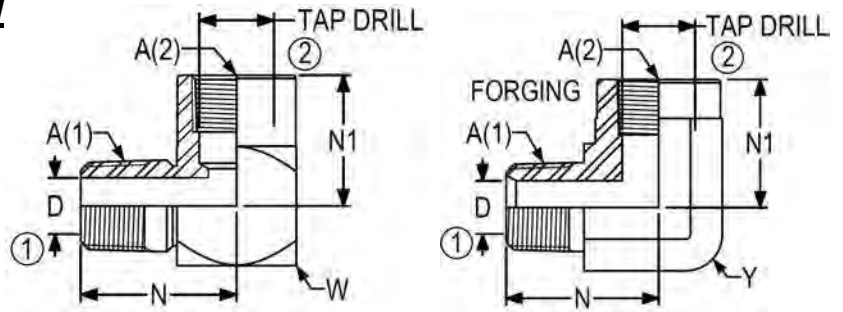

*Non forging parts are brazed construction

PART NO	A (1) NPTF	A (2) NPTF	N	N1	W	Y	D	TAP DRILL
5502-02-02	1/8-27	1/8-27	0.84	0.66	0.63	--	0.19	0.33
5502-02-02-FG	1/8-27	1/8-27	0.89	0.66	--	0.56	0.19	0.33
5502-02-04	1/8-27	1/4-18	0.91	0.88	0.75	--	0.19	0.43
5502-02-06	1/8-27	3/8-18	0.97	1.02	0.88	--	0.19	0.57
5502-04-02	1/4-18	1/8-27	1.09	0.66	0.63	--	0.28	0.33
5502-04-02-FG	1/4-18	1/8-27	1.09	0.67	--	0.75	0.28	0.33
5502-04-04	1/4-18	1/4-18	1.09	0.88	0.75	--	0.28	0.43
5502-04-04-FG	1/4-18	1/4-18	1.09	0.88	--	0.75	0.28	0.43
5502-04-06	1/4-18	3/8-18	1.16	1.02	0.88	--	0.28	0.57
5502-04-06-FG	1/4-18	3/8-18	1.22	1.02	--	0.88	0.28	0.57
5502-04-08	1/4-18	1/2-14	1.23	1.28	1.13	--	0.28	0.70
5502-06-02	3/8-18	1/8-27	1.22	0.75	0.81	--	0.41	0.33
5502-06-02-FG	3/8-18	1/8-27	1.22	0.80	--	0.88	0.41	0.33
5502-06-04	3/8-18	1/4-18	1.22	0.91	0.81	--	0.41	0.43
5502-06-04-FG	3/8-18	1/4-18	1.22	1.01	--	0.88	0.41	0.43
5502-06-06	3/8-18	3/8-18	1.22	1.02	0.88	--	0.41	0.57
5502-06-06-FG	3/8-18	3/8-18	1.38	1.02	--	0.88	0.41	0.57
5502-06-08	3/8-18	1/2-14	1.38	1.23	1.13	--	0.41	0.70
5502-06-12	3/8-18	3/4-14	1.50	1.36	1.38	--	0.41	0.91
5502-08-04	1/2-14	1/4-18	1.47	0.97	0.94	--	0.53	0.43
5502-08-04-FG	1/2-14	1/4-18	1.47	1.00	--	1.06	0.53	0.43
5502-08-06	1/2-14	3/8-18	1.47	1.05	0.94	--	0.53	0.57
5502-08-06-FG	1/2-14	3/8-18	1.47	1.01	--	1.06	0.53	0.57
5502-08-08	1/2-14	1/2-14	1.47	1.23	1.13	--	0.53	0.70
5502-08-08-FG	1/2-14	1/2-14	1.47	1.23	--	1.06	0.53	0.70
5502-08-12	1/2-14	3/4-14	1.59	1.36	1.38	--	0.53	0.91
5502-08-12-FG	1/2-14	3/4-14	1.59	1.36	--	1.31	0.53	0.91
5502-12-06	3/4-14	3/8-18	1.59	1.13	1.13	--	0.72	0.57
5502-12-08	3/4-14	1/2-14	1.59	1.23	1.13	--	0.72	0.70

5502 90 DEGREE STREET ELBOW

(Con't)

SAE J514 140239

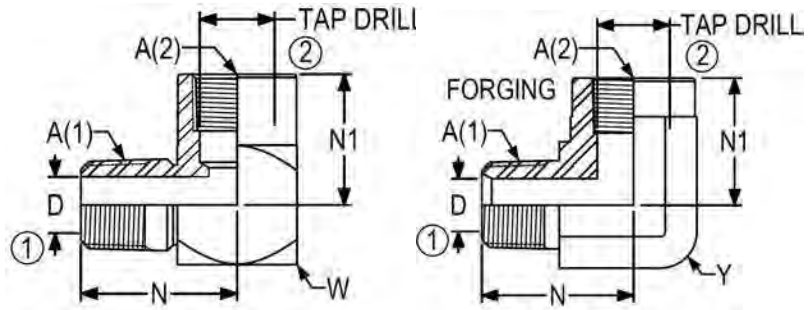

*Non forging parts are brazed construction

PART NO	A (1) NPTF	A (2) NPTF	N	N1	W	Y	D	TAP DRILL
5502-12-12	3/4-14	3/4-14	1.59	1.36	1.38	--	0.72	0.91
5502-12-12-FG	3/4-14	3/4-14	1.83	1.36	--	1.31	0.72	0.91
5502-12-16	3/4-14	1-11 1/2	1.72	1.62	1.63	--	0.72	1.14
5502-16-08	1-11 1/2	1/2-14	1.97	1.36	1.38	--	0.94	0.70
5502-16-12	1-11 1/2	3/4-14	1.84	1.36	1.38	--	0.94	0.91
5502-16-12-FG	1-11 1/2	3/4-14	1.97	1.39	--	1.63	0.94	0.91
5502-16-16	1-11 1/2	1-11 1/2	1.97	1.62	1.63	--	0.94	1.14
5502-16-16-FG	1-11 1/2	1-11 1/2	1.97	1.62	--	1.63	0.94	1.14
5502-16-20	1-11 1/2	1 1/4-11 1/2	2.16	1.70	2.00	--	0.94	1.48
5502-20-16	1 1/4-11 1/2	1-11 1/2	2.38	1.69	1.75	--	1.25	1.14
5502-20-20	1 1/4-11 1/2	1 1/4-11 1/2	2.38	1.70	2.00	--	1.25	1.48
5502-20-20-FG	1 1/4-11 1/2	1 1/4-11 1/2	2.75	1.70	--	1.88	1.25	1.48
5502-20-24	1 1/4-11 1/2	1 1/2-11 1/2	2.56	2.08	2.38	--	1.25	1.72
5502-24-24-FG	1 1/2-11 1/2	1 1/2-11 1/2	3.05	2.08	2.56	--	1.50	1.72
5502-24-24	1 1/2-11 1/2	1 1/2-11 1/2	2.64	2.08	2.38	--	1.50	1.72
5502-24-32	1 1/2-11 1/2	2-11 1/2	2.97	2.39	2.81	--	1.50	2.19
5502-24-32-FG	1 1/2-11 1/2	2-11 1/2	2.97	2.39	--	2.81	1.50	2.19
5502-32-32	2-11 1/2	2-11 1/2	3.00	2.39	2.88	--	1.94	2.19
5502-32-32-FG	2-11 1/2	2-11 1/2	3.00	2.39	--	2.81	1.94	2.20

5503 45 DEGREE STREET ELBOW

SAE J514 140339

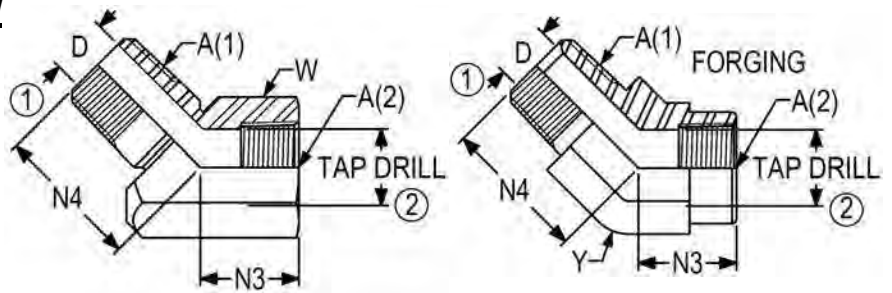

*Non forging parts are brazed construction

PART NO	A (1) NPTF	A (2) NPTF	N4	N3	W	Y	D	TAP DRILL
5503-02-02	1/8-27	1/8-27	0.72	0.47	0.63	--	0.19	0.33
5503-02-02-FG	1/8-27	1/8-27	0.72	0.47	--	0.56	0.83	0.33
5503-02-04	1/8-27	1/4-18	0.86	0.62	0.75	--	0.19	0.43
5503-04-04	1/4-18	1/4-18	1.05	0.62	0.75	--	0.28	0.43
5503-04-04-FG	1/4-18	1/4-18	1.05	0.62	--	0.75	1.19	0.43
5503-06-06	3/8-18	3/8-18	1.10	0.72	0.88	--	0.41	0.57
5503-06-06-FG	3/8-18	3/8-18	1.06	0.72	--	0.88	0.41	0.57
5503-08-06	1/2-14	3/8-18	1.34	0.91	1.13	--	0.53	0.57
5503-08-08	1/2-14	1/2-14	1.34	0.91	1.13	--	0.53	0.70
5503-08-08-FG	1/2-14	1/2-14	1.34	0.91	--	1.06	1.54	0.70
5503-12-12	3/4-14	3/4-14	1.38	0.97	1.38	--	0.72	0.91
5503-12-12-FG	3/4-14	3/4-14	1.38	0.97	--	1.31	1.64	0.91
5503-16-16	1-11 1/2	1-11 1/2	1.72	1.12	1.63	--	0.94	1.14
5503-16-20	1-11 1/2	1 1/4-11 1/2	1.77	1.63	2.00	--	0.94	1.48
5503-20-20	1 1/4-11 1/2	1 1/4-11 1/2	1.80	1.63	2.00	--	1.25	1.48
5503-24-24	1 1/2-11 1/2	1 1/2-11 1/2	2.06	1.69	2.38	--	1.50	1.72
5503-32-32	2-11 1/2	2-11 1/2	2.15	2.19	2.88	--	1.94	2.19

**5504 90 DEGREE FEMALE
PIPE ELBOW**

SAE J514 140238

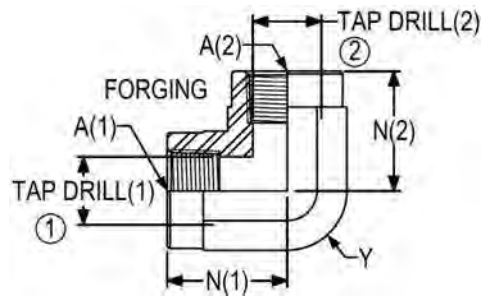
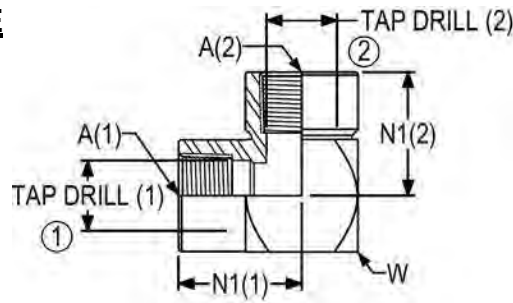

*Non forging parts are brazed construction

PART NO	A (1) NPTF	A (2) NPTF	N1 (1)	N1 (2)	W	Y	TAP DRILL (1)	TAP DRILL (2)
5504-02-02	1/8-27	1/8-27	0.66	0.66	0.63	--	0.33	0.33
5504-02-02-FG	1/8-27	1/8-27	0.66	0.66	--	0.56	0.33	0.33
5504-04-02	1/4-18	1/8-27	0.88	0.72	0.75	--	0.43	0.33
5504-04-04	1/4-18	1/4-18	0.88	0.88	0.75	--	0.43	0.43
5504-04-04-FG	1/4-18	1/4-18	0.88	0.88	--	0.75	0.43	0.43
5504-06-02	3/8-18	1/8-27	1.02	0.78	0.88	--	0.57	0.33
5504-06-04	3/8-18	1/4-18	1.02	0.94	0.88	--	0.57	0.43
5504-06-06	3/8-18	3/8-18	1.02	1.02	0.88	--	0.57	0.57
5504-06-06-FG	3/8-18	3/8-18	1.02	1.02	--	0.88	0.57	0.57
5504-08-04	1/2-14	1/4-18	1.23	1.06	1.13	--	0.70	0.43
5504-08-06	1/2-14	3/8-18	1.23	1.14	1.13	--	0.70	0.57
5504-08-08	1/2-14	1/2-14	1.23	1.23	1.13	--	0.70	0.70
5504-08-08-FG	1/2-14	1/2-14	1.23	1.23	--	1.06	0.70	0.70
5504-12-08	3/4-14	1/2-14	1.36	1.36	1.38	--	0.91	0.70
5504-12-12	3/4-14	3/4-14	1.36	1.36	1.38	--	0.91	0.91
5504-16-12	1-11 1/2	3/4-14	1.62	1.48	1.63	--	1.14	0.91
5504-16-16	1-11 1/2	1-11 1/2	1.62	1.62	1.63	--	1.14	1.14
5504-16-16-FG	1-11 1/2	1-11 1/2	1.62	1.62	--	1.63	1.14	1.14
5504-20-16	1 1/4-11 1/2	1-11 1/2	1.70	1.80	2.00	--	1.14	1.48
5504-20-20	1 1/4-11 1/2	1 1/4-11 1/2	1.70	1.70	2.00	--	1.48	1.48
5504-24-24	1 1/2-11 1/2	1 1/2-11 1/2	2.08	2.08	2.38	--	1.72	1.72
5504-32-32	2-11 1/2	2-11 1/2	2.39	2.39	2.88	--	2.19	2.19

**5505 45 DEGREE FEMALE
PIPE ELBOW**
SAE J514 140338

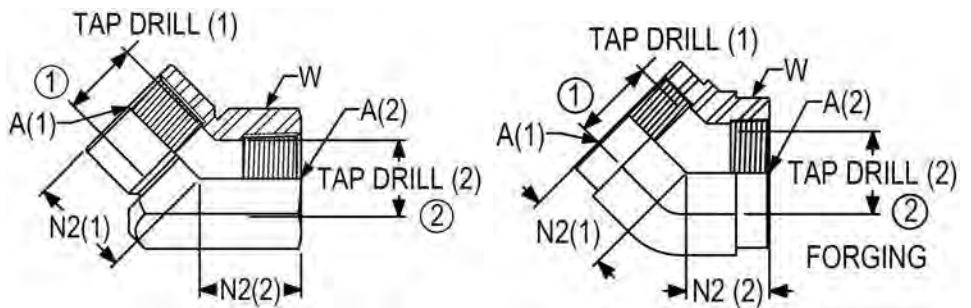

PART NO	A (1) NPTF	A (2) NPTF	N2 (1)	N2 (2)	W	TAP DRILL (1)	TAP DRILL (2)
5505-02-02	1/8-27	1/8-27	0.50	0.50	0.63	0.33	0.33
5505-04-04	1/4-18	1/4-18	0.69	0.69	0.75	0.43	0.43
5505-06-06	3/8-18	3/8-18	0.75	0.75	0.88	0.57	0.57
5505-08-08	1/2-14	1/2-14	0.94	0.94	1.13	0.70	0.70
5505-12-12	3/4-14	3/4-14	1.06	1.00	1.38	0.91	0.91
5505-16-16	1-11 1/2	1-11 1/2	1.19	1.19	1.63	1.14	1.14
5505-20-20	1 1/4-11 1/2	1 1/4-11 1/2	1.13	1.13	2.00	1.48	1.48
5505-24-24-FG	1 1/2-11 1/2	1 1/2-11 1/2	1.46	1.46	2.50	1.70	1.70

5600 MALE PIPE TEE

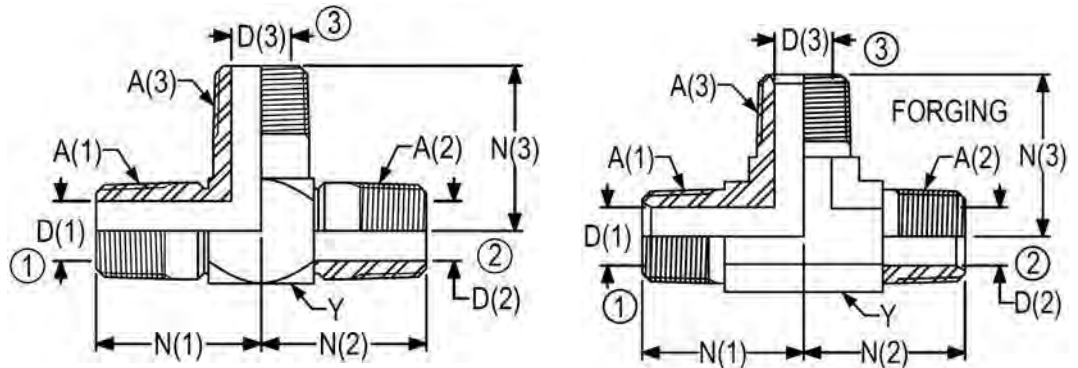

PART NO	A (1) NPTF	A (2) NPTF	A (3) NPTF	N (1)	N (2)	N (3)	Y	D (1)	D (2)	D (3)
5600-02-02-02	1/8-27	1/8-27	1/8-27	0.78	0.78	0.78	0.50	0.19	0.19	0.19
5600-02-02-02-FG	1/8-27	1/8-27	1/8-27	0.78	0.78	0.78	0.44	0.19	0.19	0.19
5600-04-04-04	1/4-18	1/4-18	1/4-18	1.09	1.09	1.09	0.63	0.28	0.28	0.28
5600-04-04-04-FG	1/4-18	1/4-18	1/4-18	1.09	1.09	1.09	0.56	0.28	0.28	0.28
5600-06-06-06	3/8-18	3/8-18	3/8-18	1.22	1.22	1.22	0.81	0.41	0.41	0.41
5600-06-06-06-FG	3/8-18	3/8-18	3/8-18	1.22	1.22	1.22	0.75	0.41	0.41	0.41
5600-08-08-08	1/2-14	1/2-14	1/2-14	1.47	1.47	1.47	0.94	0.53	0.53	0.53
5600-08-08-08-FG	1/2-14	1/2-14	1/2-14	1.47	1.47	1.47	0.88	0.53	0.53	0.53
5600-12-12-12	3/4-14	3/4-14	3/4-14	1.59	1.59	1.59	1.13	0.72	0.72	0.72
5600-12-12-12-FG	3/4-14	3/4-14	3/4-14	1.59	1.59	1.59	1.06	0.72	0.72	0.72
5600-16-16-16	1-11 1/2	1-11 1/2	1-11 1/2	1.97	1.97	1.97	1.38	0.94	0.94	0.94
5600-16-16-16-FG	1-11 1/2	1-11 1/2	1-11 1/2	1.97	1.97	1.97	1.31	0.94	0.94	0.94
5600-20-20-20	1 1/4-11 1/2	1 1/4-11 1/2	1 1/4-11 1/2	2.38	2.38	2.38	1.75	1.25	1.25	1.25
5600-24-24-24	1 1/2-11 1/2	1 1/2-11 1/2	1 1/2-11 1/2	2.64	2.64	2.64	2.00	1.50	1.50	1.50

**5601 FEMALE BRANCH
PIPE TEE**

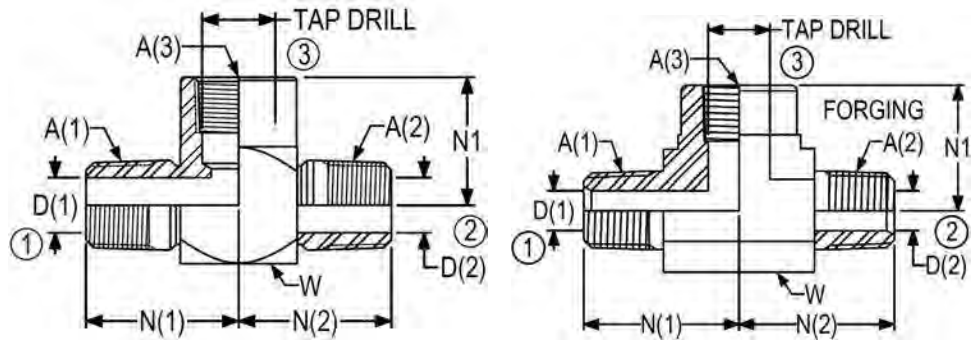

PART NO	A (1) NPTF	A (2) NPTF	A (3) NPTF	N (1)	N (2)	N1	W	D (1)	D (2)	TAP DRILL
5601-02-02-02	1/8-27	1/8-27	1/8-27	0.84	0.84	0.66	0.63	0.19	0.19	0.33
5601-04-04-04	1/4-18	1/4-18	1/4-18	1.09	1.09	0.88	0.75	0.28	0.28	0.43
5604-04-04-04-FG	1/4-18	1/4-18	1/4-18	1.09	1.09	0.88	0.75	0.28	0.28	0.43
5601-06-06-06	3/8-18	3/8-18	3/8-18	1.22	1.22	1.02	0.88	0.41	0.41	0.57
5601-08-08-08	1/2-14	1/2-14	1/2-14	1.47	1.47	1.23	1.13	0.53	0.53	0.70
5601-12-12-12	3/4-14	3/4-14	3/4-14	1.59	1.59	1.36	1.38	0.72	0.72	0.91
5601-16-16-16	1-11 1/2	1-11 1/2	1-11 1/2	1.97	1.97	1.62	1.63	0.94	0.94	1.14
5601-20-20-20	1 1/4-11 1/2	1 1/4-11 1/2	1 1/4-11 1/2	2.38	2.38	1.70	2.00	1.25	1.25	1.48

5602 MALE RUN PIPE TEE

SAE J514 140424

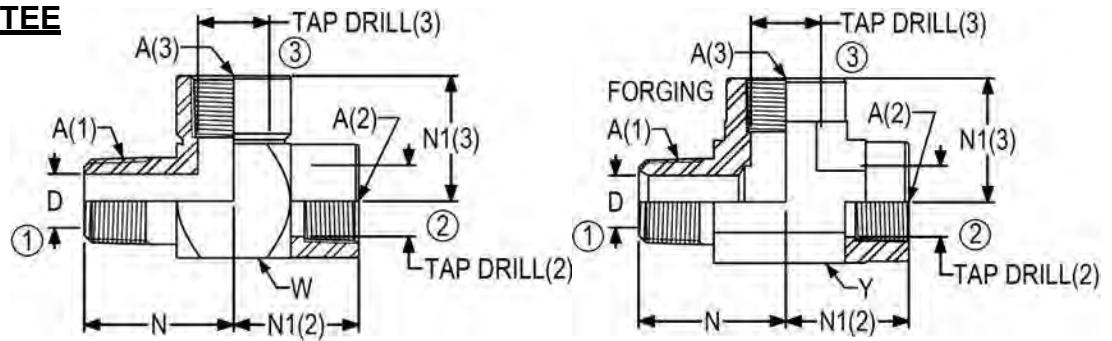

*Non forging parts are brazed construction

PART NO	A (1) NPTF	A (2) NPTF	A (3) NPTF	N	N1 (2)	N1 (3)	W	Y
5602-02-02-02	1/8-27	1/8-27	1/8-27	0.78	0.66	0.66	0.63	--
5602-02-02-04	1/8-27	1/8-27	1/4-18	0.90	0.72	0.88	0.75	--
5602-02-04-04	1/8-27	1/4-18	1/4-18	0.91	0.88	0.88	0.75	--
5602-04-04-02	1/4-18	1/4-18	1/8-27	1.09	0.88	0.72	0.75	--
5602-04-04-04	1/4-18	1/4-18	1/4-18	1.09	0.88	0.88	0.75	--
5602-04-04-04-FG	1/4-18	1/4-18	1/4-18	1.09	0.88	0.88	--	0.75
5602-06-04-06	3/8-18	1/4-18	3/8-18	1.22	0.94	1.02	0.88	--
5602-06-06-06	3/8-18	3/8-18	3/8-18	1.22	1.02	1.02	0.88	--
5602-08-08-08	1/2-14	1/2-14	1/2-14	1.47	1.23	1.23	1.13	--
5602-08-08-08-FG	1/2-14	1/2-14	1/2-14	1.47	1.23	1.23	--	1.06
5602-12-12-12	3/4-14	3/4-14	3/4-14	1.59	1.36	1.36	1.38	--
5602-12-12-12-FG	3/4-14	3/4-14	3/4-14	1.59	1.36	1.36	--	1.31
5602-16-16-16	1-11 1/2	1-11 1/2	1-11 1/2	1.97	1.62	1.62	1.63	--
5602-20-20-20	1 1/4-11 1/2	1 1/4-11 1/2	1 1/4-11 1/2	2.38	1.70	1.70	2.00	--
5602-24-24-24	1 1/2-11 1/2	1 1/2-11 1/2	1 1/2-11 1/2	2.64	2.08	2.08	2.38	--
5602-32-32-32	2-11 1/2	2-11 1/2	2-11 1/2	3.00	2.39	2.39	2.88	--

PART NO	D	TAP DRILL (2)	TAP DRILL (3)
5602-02-02-02	0.19	0.33	0.33
5602-02-02-04	0.19	0.33	0.43
5602-02-04-04	0.19	0.43	0.43
5602-04-04-02	0.28	0.43	0.33
5602-04-04-04	0.28	0.43	0.43
5602-04-04-04-FG	0.28	0.43	0.43
5602-06-04-06	0.41	0.43	0.57
5602-06-06-06	0.41	0.57	0.57
5602-08-08-08	0.53	0.70	0.70
5602-08-08-08-FG	0.53	0.70	0.70
5602-12-12-12	0.72	0.91	0.91
5602-12-12-12-FG	0.72	0.91	0.91
5602-16-16-16	0.94	1.14	1.14
5602-20-20-20	1.25	1.48	1.48
5602-24-24-24	1.50	1.72	1.72
5602-32-32-32	1.94	2.19	2.19

5603 FEMALE RUN PIPE TEE

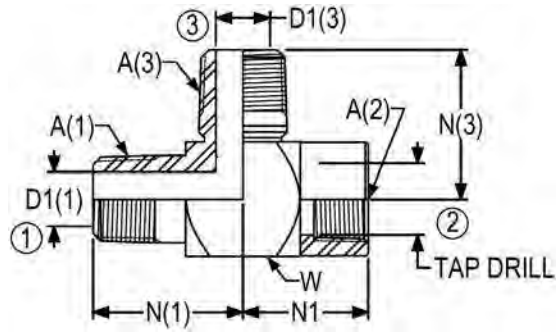

PART NO	A (1) NPTF	A (2) NPTF	A (3) NPTF	N (1)	N1	N (3)	W	D1 (1)	TAP DRILL	D1 (3)
5603-02-02-02	1/8-27	1/8-27	1/8-27	0.78	0.66	0.84	0.63	0.19	0.33	0.19
5603-04-04-04	1/4-18	1/4-18	1/4-18	1.09	0.88	1.09	0.75	0.28	0.43	0.28
5603-06-06-06	3/8-18	3/8-18	3/8-18	1.22	1.02	1.22	0.88	0.41	0.57	0.41
5603-08-08-08	1/2-14	1/2-14	1/2-14	1.47	1.23	1.47	1.13	0.53	0.70	0.53
5603-12-12-12	3/4-14	3/4-14	3/4-14	1.59	1.36	1.59	1.38	0.72	0.91	0.72
5603-16-16-16	1-11 1/2	1-11 1/2	1-11 1/2	1.97	1.62	1.97	1.63	0.94	1.14	0.94
5603-20-20-20	1 1/4-11 1/2	1 1/4-11 1/2	1 1/4-11 1/2	2.38	1.70	2.38	2.00	1.25	1.48	1.25
5603-24-24-24	1 1/2-11 1/2	1 1/2-11 1/2	1 1/2-11 1/2	2.64	2.08	2.64	2.38	1.50	1.72	1.50

5604 MALE BRANCH PIPE

TEE

SAE J514 140425

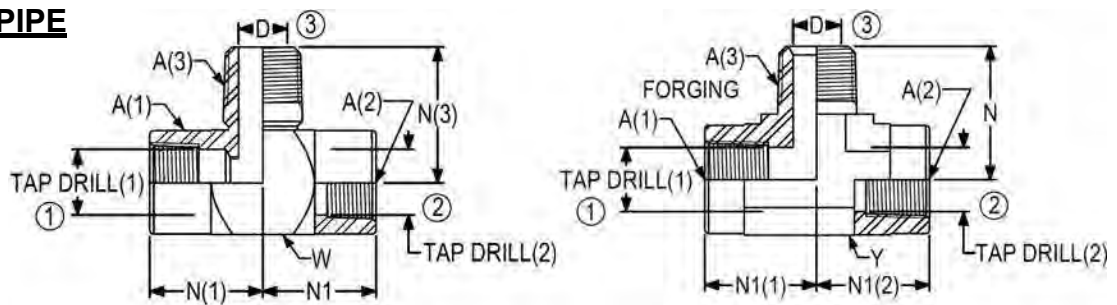

*Non forging parts are brazed construction

PART NO	A (1) NPTF	A (2) NPTF	A (3) NPTF	N1 (1)	N1 (2)	N	W	Y
5604-02-02-02	1/8-27	1/8-27	1/8-27	0.66	0.66	0.84	0.63	--
5604-04-04-04	1/4-18	1/4-18	1/4-18	0.88	0.88	1.09	0.75	--
5604-04-04-04-FG	1/4-18	1/4-18	1/4-18	0.88	0.88	1.09	--	0.75
5604-06-06-06	3/8-18	3/8-18	3/8-18	1.02	1.02	1.22	0.88	--
5604-06-06-06-FG	3/8-18	3/8-18	3/8-18	1.02	1.02	1.22	0.81	--
5604-08-08-08	1/2-14	1/2-14	1/2-14	1.23	1.23	1.47	1.13	--
5604-08-08-08-FG	1/2-14	1/2-14	1/2-14	1.23	1.23	1.47	--	1.06
5604-12-12-08	3/4-14	3/4-14	1/2-14	1.36	1.36	1.59	1.38	--
5604-12-12-12	3/4-14	3/4-14	3/4-14	1.36	1.36	1.59	1.38	--
5604-12-12-12-FG	3/4-14	3/4-14	3/4-14	1.36	1.36	1.59	--	1.31
5604-16-16-16	1-11 1/2	1-11 1/2	1-11 1/2	1.62	1.62	1.97	1.63	--
5604-20-20-20	1 1/4-11 1/2	1 1/4-11 1/2	1 1/4-11 1/2	1.70	1.70	2.38	2.00	--
5604-24-24-24	1 1/2-11 1/2	1 1/2-11 1/2	1 1/2-11 1/2	2.08	2.08	2.64	2.38	--
5604-24-24-24-FG	1 1/2-11 1/2	1 1/2-11 1/2	1 1/2-11 1/2	2.08	2.08	2.64	--	2.56

PART NO	TAP DRILL (1)	TAP DRILL (2)	D
5604-02-02-02	0.33	0.33	0.19
5604-04-04-04	0.43	0.43	0.28
5604-04-04-04-FG	0.43	0.43	0.28
5604-06-06-06	0.57	0.57	0.41
5604-06-06-06-FG	0.57	0.57	0.41
5604-08-08-08	0.70	0.70	0.53
5604-08-08-08-FG	0.70	0.70	0.53
5604-12-12-08	0.91	0.91	0.53
5604-12-12-12	0.91	0.91	0.72
5604-12-12-12-FG	0.91	0.91	0.72
5604-16-16-16	1.14	1.14	0.94
5604-20-20-20	1.48	1.48	1.25
5604-24-24-24	1.72	1.72	1.50
5604-24-24-24-FG	1.72	1.72	1.68

5605 FEMALE PIPE

TEE

SAE J514 140438

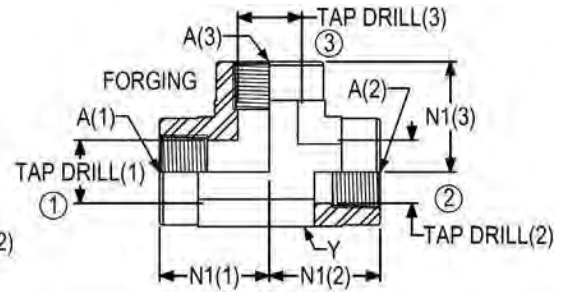
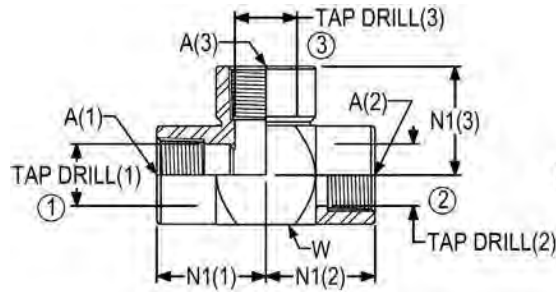

*Non forging parts are brazed construction

PART NO	A (1) NPTF	A (2) NPTF	A (3) NPTF	N1 (1)	N1 (2)	N1 (3)	W	Y
5605-02-02-02	1/8-27	1/8-27	1/8-27	0.66	0.66	0.66	0.63	--
5605-04-04-02	1/4-18	1/4-18	1/8-27	0.88	0.88	0.72	0.75	--
5605-04-04-04	1/4-18	1/4-18	1/4-18	0.88	0.88	0.88	0.75	--
5605-04-04-04-FG	1/4-18	1/4-18	1/4-18	0.88	0.88	0.88	--	0.75
5605-04-04-06	1/4-18	1/4-18	3/8-18	0.94	0.94	1.02	0.88	--
5605-06-06-06	3/8-18	3/8-18	3/8-18	1.02	1.02	1.02	0.88	--
5605-06-06-06-FG	3/8-18	3/8-18	3/8-18	1.02	1.02	1.02	--	0.75
5605-06-06-08	3/8-18	3/8-18	1/2-14	1.14	1.14	1.23	1.13	--
5605-08-06-06	1/2-14	3/8-18	3/8-18	1.23	1.14	1.14	1.13	--
5605-08-06-08	1/2-14	3/8-18	1/2-14	1.23	1.14	1.23	1.13	--
5605-08-08-06	1/2-14	1/2-14	3/8-18	1.23	1.23	1.14	1.13	--

PART NO	TAP DRILL (1)	TAP DRILL (2)	TAP DRILL (3)
5605-02-02-02	0.33	0.33	0.33
5605-04-04-02	0.43	0.43	0.33
5605-04-04-04	0.43	0.43	0.43
5605-04-04-04-FG	0.43	0.43	0.43
5605-04-04-06	0.43	0.43	0.57
5605-06-06-06	0.57	0.57	0.57
5605-06-06-06-FG	0.57	0.57	0.57
5605-06-06-08	0.57	0.57	0.70
5605-08-06-06	0.70	0.57	0.57
5605-08-06-08	0.70	0.57	0.70
5605-08-08-06	0.70	0.70	0.57

**5605 FEMALE PIPE
TEE(Con't)**
SAE J514 140438

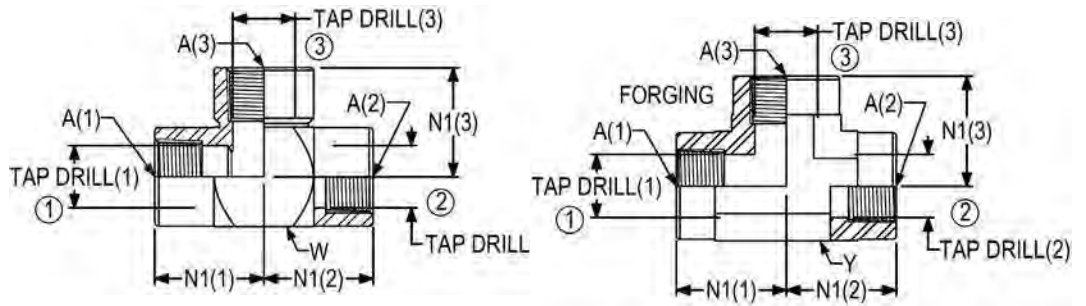

*Non forging parts are brazed construction

PART NO	A (1) NPTF	A (2) NPTF	A (3) NPTF	N1 (1)	N1 (2)	N1 (3)	W	Y
5605-08-08-08	1/2-14	1/2-14	1/2-14	1.23	1.23	1.23	1.13	--
5605-08-08-08-FG	1/4-14	1/2-14	1/2-14	1.23	1.23	1.23	--	1.06
5605-12-12-12	3/4-14	3/4-14	3/4-14	1.36	1.36	1.36	1.38	--
5605-12-12-12-FG	3/4-14	3/4-14	3/4-14	1.36	1.36	1.36	--	1.31
5605-16-16-16	1-11 1/2	1-11 1/2	1-11 1/2	1.62	1.62	1.62	1.63	--
5605-20-20-20	1 1/4-11 1/2	1 1/4-11 1/2	1 1/4-11 1/2	1.70	1.70	1.70	2.00	--
5605-24-24-24	1 1/2-11 1/2	1 1/2-11 1/2	1 1/2-11 1/2	2.08	2.08	2.08	2.38	--
5605-24-24-24-FG	1 1/2-11 1/2	1 1/2-11 1/2	1 1/2-11 1/2	2.08	2.08	2.08	--	2.56
5605-32-32-32	2-11 1/2	2-11 1/2	2-11 1/2	2.39	2.39	2.39	2.88	--

PART NO	TAP DRILL (1)	TAP DRILL (2)	TAP DRILL (3)
5605-08-08-08	0.70	0.70	0.70
5605-08-08-08-FG	0.70	0.70	0.70
5605-12-12-12	0.91	0.91	0.91
5605-12-12-12-FG	0.91	0.91	0.91
5605-16-16-16	1.14	1.14	1.14
5605-20-20-20	1.48	1.48	1.48
5605-24-24-24	1.72	1.72	1.72
5605-24-24-24-FG	1.72	1.72	1.72
5605-32-32-32	2.19	2.19	2.19

5651 FEMALE BRANCH PIPE CROSS

INFORMATION AVAILABLE UPON REQUEST.
CALL CUSTOMER SERVICE FOR DETAILS.

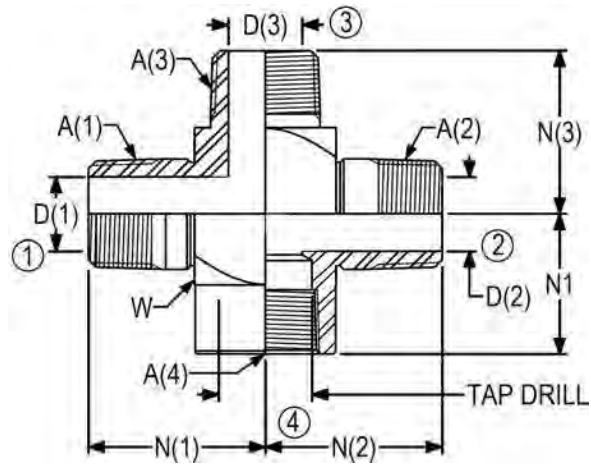

5652 FEMALE PIPE CROSS

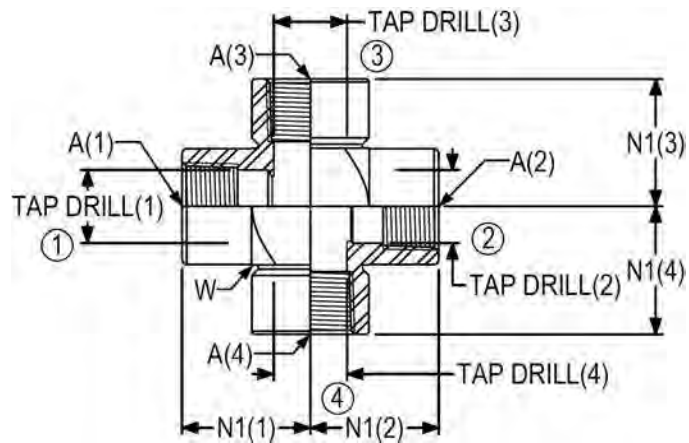

PART NO	A (1) NPTF	A (2) NPTF	A (3) NPTF	A (4) NPTF	N1 (1)	N1 (2)	N1 (3)	N1 (4)	W
5652-02-02-02-02	1/8-27	1/8-27	1/8-27	1/8-27	0.66	0.66	0.66	0.66	0.63
5652-04-04-04-04	1/4-18	1/4-18	1/4-18	1/4-18	0.88	0.88	0.88	0.88	0.75
5652-06-06-06-06	3/8-18	3/8-18	3/8-18	3/8-18	1.02	1.02	1.02	1.02	0.88
5652-08-08-08-08	1/2-14	1/2-14	1/2-14	1/2-14	1.23	1.23	1.23	1.23	1.13
5652-12-12-12-12	3/4-14	3/4-14	3/4-14	3/4-14	1.36	1.36	1.36	1.36	1.38
5652-16-16-16-16	1-11 1/2	1-11 1/2	1-11 1/2	1-11 1/2	1.62	1.62	1.62	1.62	1.63
5652-20-20-20-20	1 1/4-11 1/2	1 1/4-11 1/2	1 1/4-11 1/2	1 1/4-11 1/2	1.70	1.70	1.70	1.70	2.00
5652-24-24-24-24	1 1/2-11 1/2	1 1/2-11 1/2	1 1/2-11 1/2	1 1/2-11 1/2	2.08	2.08	2.08	2.08	2.38
5652-32-32-32-32	2-11 1/2	2-11 1/2	2-11 1/2	2-11 1/2	2.39	2.39	2.39	2.39	2.88

PART NO	TAP DRILL (1)	TAP DRILL (2)	TAP DRILL (3)	TAP DRILL (4)
5652-02-02-02-02	0.33	0.33	0.33	0.33
5652-04-04-04-04	0.43	0.43	0.43	0.43
5652-06-06-06-06	0.57	0.57	0.57	0.57
5652-08-08-08-08	0.70	0.70	0.70	0.70
5652-12-12-12-12	0.91	0.91	0.91	0.91
5652-16-16-16-16	1.14	1.14	1.14	1.14
5652-20-20-20-20	1.48	1.48	1.48	1.48
5652-24-24-24-24	1.72	1.72	1.72	1.72
5652-32-32-32-32	2.19	2.19	2.19	2.19

5653 FEMALE BRANCH/ BRANCH PIPE CROSS

INFORMATION AVAILABLE UPON REQUEST.
CALL CUSTOMER SERVICE FOR DETAILS.

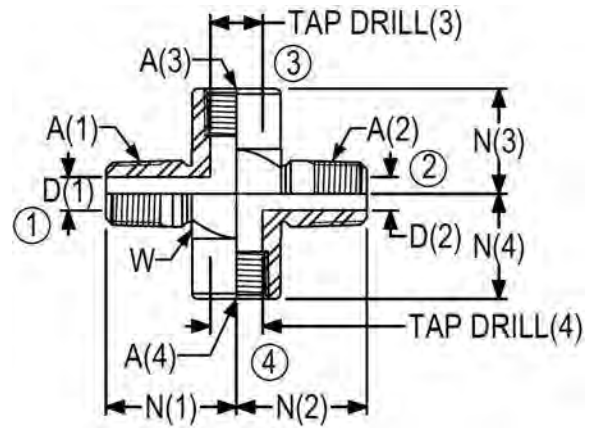

5654 FEMALE RUN/BRANCH PIPE CROSS

INFORMATION AVAILABLE UPON REQUEST.
CALL CUSTOMER SERVICE FOR DETAILS.

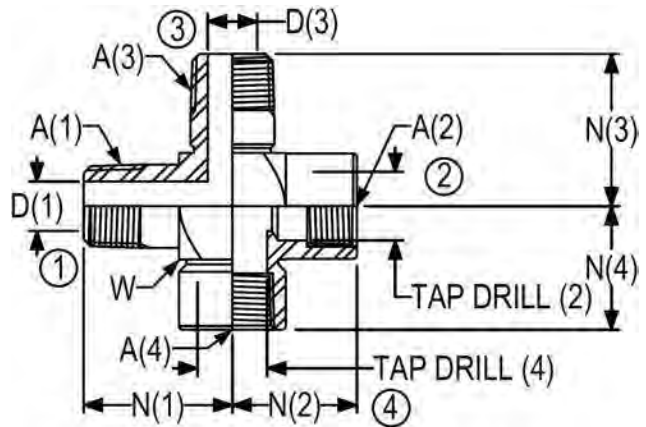

5655 MALE RUN PIPE CROSS

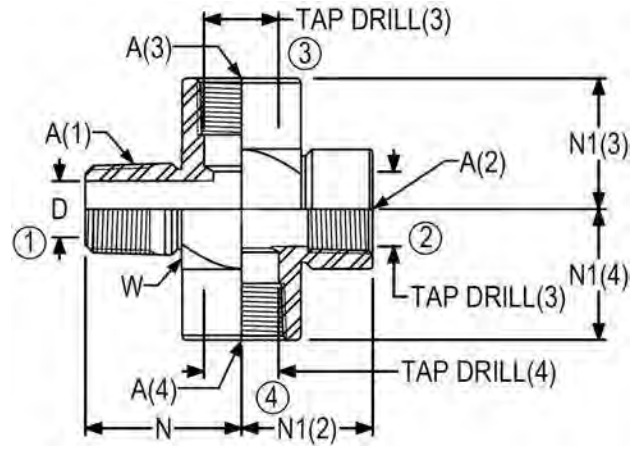

PART NO	A (1) NPTF	A (2) NPTF	A (3) NPTF	A (4) NPTF	N	N1 (2)	N1 (3)	N1 (4)	W	D
5655-04-04-04-04	1/4-18	1/4-18	1/4-18	1/4-18	1.09	0.88	0.88	0.88	0.75	0.28
5655-06-06-06-06	3/8-18	3/8-18	3/8-18	3/8-18	1.22	1.02	1.02	1.02	0.88	0.41
5655-08-08-08-08	1/2-14	1/2-14	1/2-14	1/2-14	1.47	1.23	1.23	1.23	1.13	0.53
5655-16-16-16-16	1-11 1/2	1-11 1/2	1-11 1/2	1-11 1/2	1.97	1.62	1.62	1.62	1.63	0.94

PART NO	TAP DRILL (2)	TAP DRILL (3)	TAP DRILL (4)
5655-04-04-04-04	0.43	0.43	0.43
5655-06-06-06-06	0.57	0.57	0.57
5655-08-08-08-08	0.70	0.70	0.70
5655-16-16-16-16	1.14	1.14	1.14

Long Allen Plugs

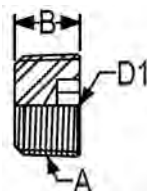

PART NO	A NPTF	B	D1
1/16 LONG ALLEN PLUG	1/16-27	0.30	0.16
1/8 LONG ALLEN PLUG	1/8-27	0.30	0.19
1/4 LONG ALLEN PLUG	1/4-18	0.46	0.25
3/8 LONG ALLEN PLUG	3/8-18	0.46	0.31
1/2 LONG ALLEN PLUG	1/2-14	0.61	0.38
3/4 LONG ALLEN PLUG	3/4-14	0.62	0.56
1" LONG ALLEN PLUG	1-11 1/2	0.77	0.63
1 1/4 LONG ALLEN PLUG	1 1/4-11 1/2	0.81	0.75
2" LONG ALLEN PLUG	2-11 1/2	0.89	1.00

Features. Four Bolt Flange Fittings

SAE J518, Code 61 and Code 62 Four-Bolt Split Flange connections are non-threaded port ends which utilize O-Rings for sealing. They are assembled to ports with split flange clamp halves and clamping pressure is provided by bolts or socket head cap screws of SAE Grade 5 material or better as specified in SAE J429. Rated design factor for these connections is dependent on the selected grade for the clamp bolts. Flanged head ends are incorporated into fittings having suitable means for attachment to tubes, pipes or hoses to provide connection ends.

Performance

Four bolt flange ends conform to SAE J518.

Construction

Unless otherwise specified, fittings are machined from carbon steel and may utilize brazed construction for shaped fittings. Standard plating is Zinc with a yellow Dichromate finish per ASTM B633 (Type II SC2) and is rated at 96 hours minimum salt spray resistance.

Threads

Unless otherwise specified, fittings are machined from cold drawn carbon steel barstock and forgings. Standard plating is electrodeposited zinc with a clear trivalent chromate conversion coating in accordance with ASTM B633 (Type V SC2). The minimum salt spray resistance is 240 hours to red corrosion when tested in accordance with ASTM B117.

NPTF Threads: Male and female pipe threads conform to the Dryseal American Standard Taper Pipe Thread (SAE J476a, NPTF) Series which will provide pressure tight joints without the use of a lubricant or sealer. Use of these fittings with non-dryseal NPT pipe or hose ends is not recommended for high-pressure applications.

Note: Where not functionally objectionable, use of a compatible lubricant/sealant is recommended for either NPT or NPTF threads to minimize the possibility of galling in assembly.

NPSM Swivels: Female threads for adapter union swivel nuts conform to the American Standard Straight Pipe Thread (NPSM) Series. These threads mate with either NPT or NPTF Series male threads to provide a mechanical connection between the adapter and mating male end. Sealing is provided by metal to metal contact between the machined 30 degree female seat on the NPT/NPTF male end and the nose of the swivel end. The NPSM swivel threads are not a sealing member.

Caution: For proper sealing, ensure that the mating male end has been machined with the proper 30 degree female seat.

Assembly Information

For assembly instructions, refer to the Technical Data Section for the appropriate fitting end. Also, refer to the Technical Data Section for recommendations regarding tubing pressure ratings, tube flares and hose/tube routing information. Please note the following:

Tubing for single flare tube ends should be either seamless or welded and drawn, fully annealed tubing per SAE J524 or J525. For double flaring, tubing per SAE J356, J524, J525 or J526 may be used.

For proper sealing with 37 degree flared fittings, flares for tubing should conform to the requirements of SAE J533. For heavy wall tubing, the optional tube preparation and single flare configuration specified in SAE J533 is also recommended. This optional configuration provides extended sealing surface contact area versus conventional flares.

In the design and fabrication of tubing or hose runs for any hydraulic system, precautions should be taken to allow for sufficient adjustment of the hose or tubing so that proper alignment can be attained at the fitting connections. Improper fit-up or misalignment should be corrected before final connections are made. Location of fitting connections should be planned to maximize accessibility. Whenever possible, use a torque wrench to tighten connections to the recommended torque.

Ordering Information

Size of fittings are indicated by dash number relating to sixteenths of an inch for the nominal O.D. of the tube size used. Example: 1/2 inch tube = 8/16 or (-8) size.

Order standard fittings from appropriate chart indicating required dash numbers. For example, 6405-08-06-O is 1/2" O-Ring stud end with 3/4-16 straight thread, and 3/8" female pipe thread. Jump size 6405-16-08-O is 1" O-Ring stud end with 1 5/16-12 straight thread and 1/2" female pipe thread. Pictorial views for each fitting style indicate the correct numbering sequence for fitting ends.

If information is needed for jump sizes not shown, please contact customer service for engineering assistance.

Table JF1. Pressure Ratings for 37 Deg. Flared Tube Ends, 37 Deg. Female Swivels, O-Ring Port Plugs and Straight Thread Stud Ends (Inch)

Nominal Tube Size		Thread Size	Working Pressures							
Nom SAE Dash Size	Nom Inch Tube O.D.	SAE J514 Flared Tube End and SAE J1926/3/ ISO 11926-3 O-Ring Port Thread Size (Notes 1&2)	37 Deg. Flared Tube Ends, Unions and Bulkheads		37 Deg. Female Swivels		SAE J514 (Inch) Port Plugs and Stud Ends Per SAE J1926/3/ISO 11926-3			
			MPa	psi	Mpa	psi	Port Plugs/Non-Adjustable Studs		Adjustable Studs	
							MPa	psi	MPa	psi
-02	1/8	5/16-24 UNF	34.5	5,000	34.5	5,000	34.5	5,000	34.5	5,000
-03	3/16	3/8-24 UNF	34.5	5,000	34.5	5,000	34.5	5,000	34.5	5,000
-04	1/4	7/16-20 UNF	34.5	5,000	31	4,500	34.5	5,000	31.5	4,500
-05	5/16	1/2-20 UNF	34.5	5,000	27.5	4,000	34.5	5,000	27.5	4,000
-06	3/8	9/16-18 UNF	34.5	5,000	27.5	4,000	34.5	5,000	27.5	4,000
-08	1/2	3/4-16 UNF	31	4,500	27.5	4,000	31	4,500	27.5	4,000
-10	5/8	7/8-14 UNF	24	3,500	21	3,000	24	3,500	21	3,000
-12	3/4	1-1/16-12 UN	24	3,500	21	3,000	24	3,500	21	3,000
-14	7/8	1-3/16-12 UN	21	3,000	17	2,500	21	3,000	17	2,500
-16	1	1-5/16-12 UN	21	3,000	17	2,500	21	3,000	17	2,500
-20	1 1/4	1-5/8-12 UN	17	2,500	14	2,000	17	2,500	14	2,000
-24	1 1/2	1-7/8-12 UN	14	2,000	10.5	1,500	14	2,000	10.5	1,500
-32	2	2-1/2-12 UN	10.5	1,500	8	1,125	10.5	1,500	8	1,125

1) Threads per SAE J475 Class 2A ext. Class 2B int. (Ref. ISO-263/ISO-R725)
 2) Unified class 2B threads apply to swivel nuts and with minor diameter modified to class 3B limits for locknuts

Table JF2. Pressure Ratings for Fittings With NPTF Pipe Threads and Adapter Unions

Nominal Pipe Size		Thread Size		Working Pressures			
Nom SAE Dash Size	Nom Inch Pipe O.D.	Dryseal Pipe Thread (NPTF ¹) Male and Female	Straight Pipe Thread (NPSM ²) Female Swivels	Fittings With NPTF Pipe Threads		Adapter Unions	
				MPa	psi	MPa	psi
-02	1/8	1/8-27	1/8-27	34.5	5,000	34.5	5,000
-04	1/4	1/4-18	1/4-18	27.5	4,000	34.5	5,000
-06	3/8	3/8-18	3/8-18	21	3,000	27.6	4,000
-08	1/2	1/2-14	1/2-14	21	3,000	24.1	3,500
-12	3/4	3/4-14	3/4-14	17	2,500	15.5	2,250
-16	1	1-11-1/2	1-11-1/2	14	2,000	13.8	2,000
-20	1 1/4	1-1/4-11-1/2	1-1/4-11-1/2	8	1,150	11.2	1,625
-24	1 1/2	1-1/2-11-1/2	1-1/2-11-1/2	7	1,000	8.6	1,250
-32	2	2-11-1/2	2-11-1/2	7	1,000	7.8	1,125

1) Dryseal American Standard Taper Pipe Thread
 2) American Standard Straight Pipe Thread for Mechanical Joints

Table JF3. Pressure Ratings for Code 61 Four-Bolt Split Flange Ends

Nominal Flange Size		Bolt Dimensions			Working Pressures @ Recommended Torque (Note: See Below)			
Nom SAE Dash Size	Nom Inch Pipe O.D.	Thread	Length		Maximum Recommended Working Pressure		Recommended Torque Range	
			mm	inch	MPa	psi	Nm	lb-in
-08	1/2	5/16-18	32	1-1/4	34.5	5,000	20-25	175-225
-12	3/4	3/8-16	32	1-1/4	34.5	5,000	28-40	250-350
-16	1	3/8-16	32	1-1/4	34.5	5,000	37-48	325-425
-20	1 1/4	7/16-14	38	1-1/2	27.6	4,000	48-62	425-550
-24	1 1/2	1/2-13	38	1-1/2	20.7	3,000	62-79	550-700
-32	2	1/2-13	38	1-1/2	20.7	3,000	73-90	650-800

Table JF4. Pressure Ratings for Code 62 Four-Bolt Split Flange Ends

Nominal Flange Size		Bolt Dimensions			Working Pressures @ Recommended Torque (Note: See Below)			
Nom SAE Dash Size	Nom Inch Pipe O.D.	Thread	Length		Maximum Recommended Working Pressure		Recommended Torque Range	
			mm	inch	MPa	psi	Nm	lb-in
-08	1/2	5/16-18	32	1-1/4	41.4	6,000	20-25	175-225
-12	3/4	3/8-16	38	1-1/2	41.4	6,000	34-45	300-400
-16	1	7/16-14	44	1-3/4	41.4	6,000	56-68	500-600
-20	1 1/4	1/2-13	44	1-3/4	41.4	6,000	85-102	750-900
-24	1 1/2	5/8-11	57	2-1/4	41.4	6,000	158-181	1400-1600
-32	2	3/4-10	70	2-3/4	41.4	6,000	271-294	2400-2600

Note: SAE J518, Code 61 and Code 62 Four-Bolt Split Flange connections are non-threaded port ends which utilize O-Rings for sealing. They are assembled to ports with split flange clamp halves and clamping pressure is provided by bolts or socket head cap screws of SAE Grade 5 material or better as specified in SAE J429. Rated design factor for these connections is

dependent on the selected grade for the clamp bolts. Flanged head ends are incorporated into fittings having suitable means for attachment to tubes, pipes or hoses to provide connection ends.

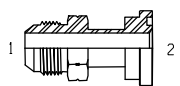
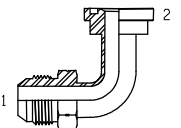
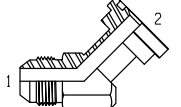
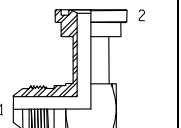
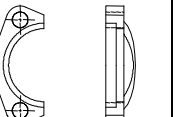
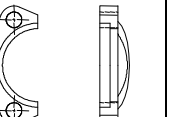
 <p>1700-Str. (1)Male Tube (2)O-Ring Flange</p>	 <p>1701-90° (1)Male Tube (2)O-Ring Flange</p>	 <p>1703-45° (1)Male Tube (2)O-Ring Flange</p>	 <p>1704-90° (1)Male Tube (2)O-Ring Flange</p>	 <p>31205-61- Code 61 Split Flange Clamp</p>	 <p>31205-62- Code 62 Split Flange Clamp</p>	
---	--	--	--	---	--	--

1700-61 CODE 61 FLANGE ADAPTER

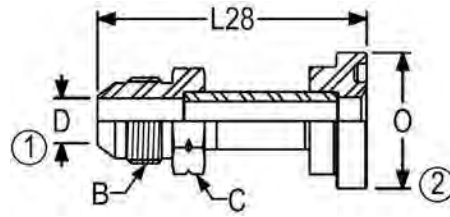

PART NO	TUBE OD	B UN/UNF-2A	L28	C	D	O
1700-61-08-08	1/2	3/4-16	2.36	0.81	0.39	1.19
1700-61-08-12	1/2	3/4-16	2.31	0.94	0.39	1.50
1700-61-12-12	3/4	1 1/16-12	2.63	1.13	0.61	1.50
1700-61-12-16	3/4	1 1/16-12	2.61	1.13	0.61	1.75
1700-61-12-20	3/4	1 1/16-12	2.63	1.38	0.61	2.00
1700-61-16-12	1	1 5/16-12	2.66	1.38	0.61	1.50
1700-61-16-16	1	1 5/16-12	2.66	1.38	0.84	1.75
1700-61-16-20	1	1 5/16-12	2.66	1.38	0.84	2.00
1700-61-16-24	1	1 5/16-12	3.33	1.38	0.84	2.38
1700-61-20-16	1 1/4	1 5/8-12	2.78	1.69	0.84	1.75
1700-61-20-20	1 1/4	1 5/8-12	2.71	1.69	1.08	2.00
1700-61-20-24	1 1/4	1 5/8-12	2.81	1.69	1.08	2.37
1700-61-24-20	1 1/2	1 7/8-12	2.99	2.00	1.08	2.00
1700-61-24-24	1 1/2	1 7/8-12	3.02	2.00	1.31	2.38
1700-61-24-32	1 1/2	1 7/8-12	3.03	2.00	1.31	2.81
1700-61-32-32	2	2 1/2-12	3.45	2.63	1.78	2.81

**1701-61 90 DEGREE CODE 61 BENT TUBE
FLANGE ADAPTER ELBOW**

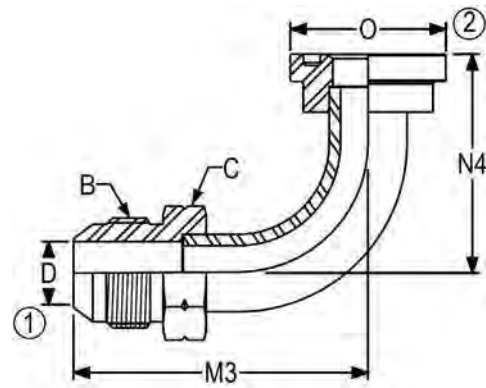

PART NO	TUBE OD	B UN/UNF-2A	N4	M3	C	D	O
1701-61-12-12	3/4	1 1/16-12	2.12	2.84	1.13	0.61	1.50
1701-61-16-16	1	1 5/16-12	2.38	3.14	1.38	0.84	1.75
1701-61-16-20	1	1 5/16-12	2.37	2.79	1.38	0.84	2.00
1701-61-20-16	1 1/4	1 7/8-12	2.38	3.26	1.69	1.08	1.75
1701-61-20-20	1 1/4	1 7/8-12	2.50	3.33	1.69	1.08	2.00
1701-61-24-20	1 1/2	1 7/8-12	2.50	3.52	2.00	1.31	2.00
1701-61-24-24	1 1/2	1 7/8-12	2.75	3.67	2.00	1.31	2.38

**1703-61 45 DEGREE CODE 61 FLANGE
ADAPTER ELBOW**

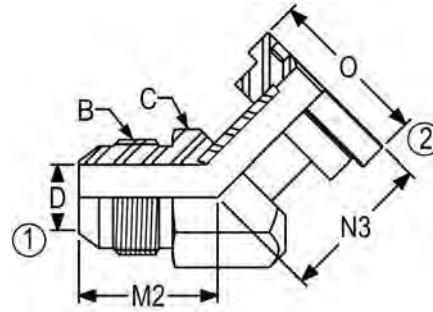

PART NO	TUBE OD	B UN/UNF-2A	N3	M2	C	O	D
1703-61-12-12	3/4	1 1/16-12	1.41	1.28	1.13	1.50	0.61
1703-61-16-16	1	1 5/16-12	1.50	1.47	1.38	1.75	0.84
1703-61-20-20	1 1/4	1 5/8-12	1.63	1.78	1.75	2.00	1.08
1703-61-24-24	1 1/2	1 7/8-12	1.98	1.78	2.00	2.38	1.31
1703-61-32-32	2	2 1/2-12	2.97	2.22	2.63	2.81	1.78

**1704-61 90 DEGREE CODE 61 FLANGE
ADAPTER ELBOW**

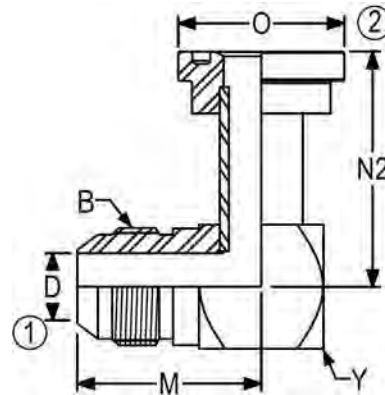

PART NO	TUBE OD	B UN/UNF-2A	N2	M	Y	O	D
1704-61-12-12	3/4	1 1/16-12	2.13	1.66	1.13	1.50	0.61
1704-61-16-16	1	1 5/16-12	2.38	1.81	1.38	1.75	0.84
1704-61-20-20	1 1/4	1 5/8-12	2.50	2.06	1.75	2.00	1.08
1704-61-24-24	1 1/2	1 7/8-12	2.75	2.33	2.00	2.38	1.31
1704-61-32-32	2	2 1/2-12	3.25	3.06	2.63	2.81	1.78

31205-61 CODE 61 SPLIT FLANGE CLAMP

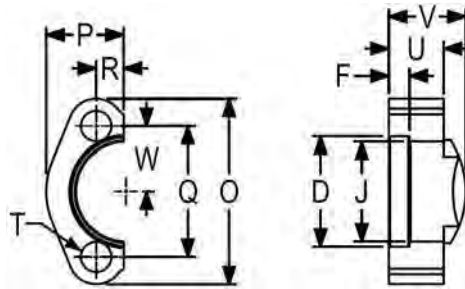

PART NO	FLANGE SIZE	D	F	J	O	P	Q	R	T	U	V
31205-61-8	1/2	1.22	0.24	0.95	2.13	0.86	1.50	0.31	0.35	0.50	0.75
31205-61-12	3/4	1.53	0.24	1.26	2.56	0.98	1.88	0.40	0.42	0.56	0.89
31205-61-16	1	1.78	0.30	1.51	2.75	1.11	2.06	0.48	0.42	0.62	0.94
31205-61-20	1 1/4	2.03	0.30	1.72	3.13	1.39	2.31	0.56	0.47	0.56	0.89
31205-61-24	1 1/2	2.41	0.30	2.00	3.69	1.58	2.75	0.67	0.52	0.62	1.00
31205-61-32	2	2.84	0.35	2.47	4.00	1.86	3.06	0.81	0.52	0.62	1.00
31205-61-40	2 1/2	3.34	0.35	2.95	4.50	2.09	3.50	0.96	0.52	0.75	1.50
31205-61-48	3	4.03	0.35	3.58	5.32	2.53	4.19	1.18	0.66	0.88	1.61

31205-62 CODE 62 SPLIT FLANGE CLAMP

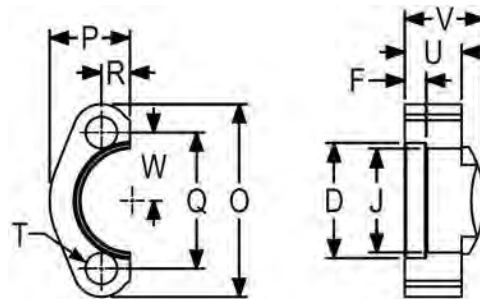

PART NO	FLANGE SIZE	D	F	J	O	P	Q	R	T	U	V
31205-62-8	1/2	1.28	0.28	0.97	2.22	0.89	1.59	0.32	0.35	0.62	0.89
31205-62-12	3/4	1.65	0.32	1.28	2.81	1.14	2.00	0.43	0.42	0.75	1.12
31205-62-16	1	1.91	0.35	1.53	3.19	1.33	2.25	0.51	0.47	0.94	1.32
31205-62-20	1 1/4	2.16	0.39	1.75	3.75	1.48	2.63	0.59	0.52	1.06	1.50
31205-62-24	1 1/2	2.53	0.48	2.03	4.44	1.83	3.13	0.68	0.66	1.19	1.69
31205-62-32	2	3.16	0.48	2.66	5.25	2.20	3.81	0.84	0.81	1.44	2.07

Features. JIC/ORFS Conversion Fittings

O-Ring face seal fittings are intended for general application in industrial and commercial hydraulic systems, where the use of elastomeric seals is acceptable to prevent leakage. These fittings are capable of operating at working pressures from 28 in. Hg (95-kPa) vacuum to 6,000 psi (41.3 MPa) as specified in the tables below. Fitting styles are available to provide connections between tubing, male or female NPTF pipe and SAE J1926/1/ISO-11926-1 O-Ring ports.

ORFS fittings supplied by Air-Way feature the SAE J1453 "Style B" O-Ring groove design for the tube connection end, which provides improved O-Ring retention.

ORFS fittings are typically joined to tubing by means of a braze on tube sleeve and tube nut. Tube preparation and brazing processes follow standard industry practices for high quality braze joints.

The design of the ORFS fitting tube end is identical for either inch or metric tubing. With the exception of stock size, the tube fittings described in this section are interchangeable with equivalent fitting styles (unions, bulkheads, tees, etc.) per ISO 8434-3.

37 degree flared tube fittings provide leakproof, full flow connections in hydraulic systems operating at working pressures as specified in the tables below. A large variety of fitting styles are available to allow connection of flared tube ends, machined male or female 37 degree ends or male or female NPTF pipe or hose ends. Also included in this section are low-pressure beaded hose stem fittings.

37 degree flared fittings are the most commonly used tube connection in worldwide use today. Tube preparation and flaring processes are easily accomplished with either hand or power tools. The large variety of fitting configurations and jump sizes available provide for simplified fabrication requirements and reduced parts count in complex systems.

The design of the 37 degree flared fitting tube end is identical for either inch or metric tubing. With the exception of stock size, the flared tube fittings described in this section are interchangeable with equivalent fitting styles (unions, bulkheads, tees, etc.) per ISO 8434-2.

All 37 degree fitting styles are also available with the optional **FLARE-O** tube end design. Call for details.

Performance

Where applicable, fittings are designed and qualified to the requirements of SAE J1453 and J514.

Construction

Unless otherwise specified, fittings are machined from cold drawn carbon steel barstock and forgings. Standard plating is electrodeposited zinc with a clear trivalent chromate conversion coating in accordance with ASTM B633 (Type V SC2). The minimum salt spray resistance is 240 hours to red corrosion when tested in accordance with ASTM B117.

Threads

Straight Threads: Internal and external straight threads conform to the Unified National Class 2A and Class 2B Series respectively, with modified minor diameters where specified. Plated external threads may conform to Class 3A maximum diameters after plating.

NPTF Threads: Male and female pipe threads conform to the Dryseal American Standard Taper Pipe Thread (SAE J476a, NPTF) Series which will provide pressure tight joints without the use of a lubricant or sealer. Use of these fittings with non-dryseal NPT pipe or hose ends is not recommended for high-pressure applications.

Note: Where not functionally objectionable, use of a compatible lubricant/sealant is recommended for either NPT or NPTF threads to minimize the possibility of galling in assembly.

Assembly Information

For brazing and assembly instructions, refer to the Technical Data Section for the appropriate fitting end. Also, refer to the Technical Data Section for recommendations regarding tubing pressure ratings and hose/tube routing information.

Tubing for single flare tube ends should be either seamless or welded and drawn, fully annealed tubing per SAE J524 or J525. For double flaring, tubing per SAE J356, J524, J525 or J526 may be used.

For proper sealing with 37 degree flared fittings, flares for tubing should conform to the requirements of SAE J533. For heavy wall tubing, the optional tube preparation and single flare configuration specified in SAE J533 is also recommended. This optional configuration provides extended sealing surface contact area versus conventional flares.

Please note the following:

In the design and fabrication of tubing or hose runs for any hydraulic system, precautions should be taken to allow for sufficient adjustment of the hose or tubing so that proper alignment can be attained at the fitting connections. Improper fit-up or misalignment should be corrected before final connections are made. Location of fitting connections should be planned to maximize accessibility.

Whenever possible, use a torque wrench to tighten connections to the recommended installation torque.

Bulkhead fittings may be ordered with or without lock nuts. To order fittings with lock nut, add (-LN) suffix to base catalog part number.

Ordering Information

Size of fittings are indicated by dash number relating to sixteenths of an inch for the nominal O.D. of the tube size used. Example: 1/2 inch tube = 8/16 or (-8) size.

If information is needed for jump sizes not shown, please contact customer service for engineering assistance. Dimensions are rounded for brevity. Please contact factory for exact dimensions and tolerances.

Order standard fittings from appropriate chart indicating required dash numbers. For example, FF7403-08-08 is 1/2" ORFS tube end with 13/16-16 straight thread and 1/2" 37deg. male tube end with 3/4-16 straight thread. Jump size FF7403-08-06 is 1/2" ORFS tube end with 13/16-16 straight thread and 3/8" 37 deg male tube end with 9/16- 18 straight thread. Pictorial views for each fitting style indicate the correct numbering sequence for fitting ends.

Nominal Tube Size		Thread Size (Notes 1&2)		Working Pressures					
Nom SAE Dash Size	Nom Inch Tube O.D.	SAE J1453 ORFS Tube End	SAE J1926/2/ ISO 11926-2 O-Ring Port Thread Size	ORFS Tube Ends, Unions and Bulkheads		Heavy Duty Stud Ends Per SAE J1926/2/ISO 11926-2			
						Non-Adjustable Studs		Adjustable Studs	
				Mpa	psi	MPa (3)	psi	MPa (3)	psi
-04	1/4	9/16-18 UNF	7/16-20 UNF	41.3	6,000	63	9,000	40	6,000
-05	5/16	5/8-18 UNF	1/2-20 UNF	41.3	6,000	63	9,000	40	6,000
-06	3/8	11/16-16 UNF	9/16-18 UNF	41.3	6,000	63	9,000	40	6,000
-08	1/2	13/16-16 UNF	3/4-16 UNF	41.3	6,000	63	9,000	40	6,000
-10	5/8	1-14 UNF	7/8-14 UNF	41.3	6,000	63	9,000	40	6,000
-12	3/4	1-3/16-12 UN	1-1/16-12 UN	41.3	6,000	40	6,000	40	6,000
-14	7/8	1-5/16-12 UN	1-3/16-12 UN	41.3	6,000	40	6,000	40	6,000
-16	1	1-7/16-12 UN	1-5/16-12 UN	41.3	6,000	40	6,000	31.5	5,000
-20	1 1/4	1-11/16-12 UN	1-5/8-12 UN	27.5	4,000	25	4,000	25	4,000
-24	1 1/2	2-12 UN	1-7/8-12 UN	27.5	4,000	25	4,000	20	3,000

- 1) Threads per SAE J475 Class 2A ext. Class 2B int. (Ref. ISO-263/ISO-R725)
- 2) Unified class 2B threads apply to swivel nuts and with minor diameter modified to class 3B limits for locknuts
- 3) MPa ratings for J1926/2/ISO 11926-2 stud ends are rationalized values as published in those standards.

Nominal Pipe Size		Thread Size	Working Pressures	
Nom SAE Dash Size	Nom Inch Pipe O.D.	Dryseal Pipe Thread (NPTF) Male and Female	Fittings With NPTF Pipe Threads	
			MPa	psi
-02	1/8	1/8-27	34.5	5,000
-04	1/4	1/4-18	27.5	4,000
-06	3/8	3/8-18	21	3,000
-08	1/2	1/2-14	21	3,000
-12	3/4	3/4-14	17	2,500
-16	1	1-11-1/2	14	2,000
-20	1 1/4	1-1/4-11-1/2	8	1,150
-24	1 1/2	1-1/2-11-1/2	7	1,000
-32	2	2-11-1/2	7	1,000

1) Dryseal American Standard Taper Pipe Thread

Table JO3. Pressure Ratings for 37 Deg. Flared Tube Ends, Unions, Bulkheads and 37 Deg. Female Swivels						
Nominal Tube Size		Thread Size	Working Pressures			
Nom SAE Dash Size	Nom Inch Tube O.D.	SAE J514 Flared Tube End and SAE J1926/3/ ISO 11926-3 O-Ring Port Thread Size (Notes 1&2)	37 Deg. Flared Tube Ends, Unions and Bulkheads		37 Deg. Female Swivels	
			MPa	psi	MPa	psi
-02	1/8	5/16-24 UNF	34.5	5,000	34.5	5,000
-03	3/16	3/8-24 UNF	34.5	5,000	34.5	5,000
-04	1/4	7/16-20 UNF	34.5	5,000	31	4,500
-05	5/16	1/2-20 UNF	34.5	5,000	27.5	4,000
-06	3/8	9/16-18 UNF	34.5	5,000	27.5	4,000
-08	1/2	3/4-16 UNF	31	4,500	27.5	4,000
-10	5/8	7/8-14 UNF	24	3,500	21	3,000
-12	3/4	1-1/16-12 UN	24	3,500	21	3,000
-14	7/8	1-3/16-12 UN	21	3,000	17	2,500
-16	1	1-5/16-12 UN	21	3,000	17	2,500
-20	1 1/4	1-5/8-12 UN	17	2,500	14	2,000
-24	1 1/2	1-7/8-12 UN	14	2,000	10.5	1,500
-32	2	2-1/2-12 UN	10.5	1,500	8	1,125

1) Threads per SAE J475 Class 2A ext. Class 2B int. (Ref. ISO-263/ISO-R725)

2) Unified class 2B threads apply to swivel nuts and with minor diameter modified to class 3B limits for locknuts

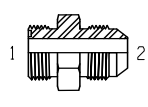
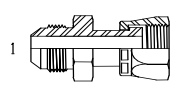
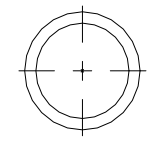
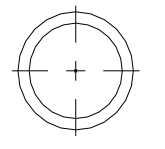
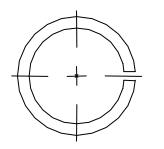
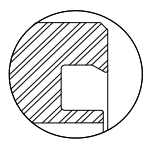
 <p>FF7403-Str. (1) Male ORFS (2) Male JIC</p>	 <p>FF7504-Str. (1) Male Tube (2) ORFS Female Swivel</p>		<p>(J515CH)</p>  <p>FF4000-O-Ring SAE J1453/2/3 Face Seal Ends</p>	<p>(J515CH)</p>  <p>4000-O-Ring SAE J1926/2/3 Inch Stud Ends</p>	 <p>FF9000-Braze Ring</p>	 <p>Style B, Dovetail Groove</p>
--	--	--	--	---	---	--

FF7403 MALE ORFS ADAPTER/37 DEGREE

MALE JIC

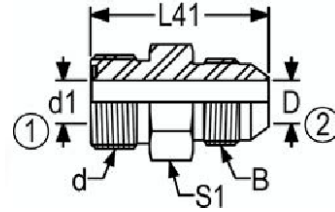

PART NO	TUBE OD	d UN/UNF-2A	B UN/UNF-2A	L41	S1	d1	D
FF7403-04-04	1/4-1/4	9/16-18	7/16-20	1.25	0.63	0.17	0.17
FF7403-06-06	3/8-3/8	11/16-16	9/16-18	1.34	0.75	0.26	0.26
FF7403-08-08	1/2-1/2	13/16-16	3/4-16	1.55	0.88	0.38	0.38
FF7403-10-10	5/8-5/8	1-14	7/8-14	1.83	1.06	0.48	0.48
FF7403-12-12	3/4-3/4	1 3/16-12	1 1/16-12	2.05	1.25	0.61	0.61
FF7403-16-16	1-1	1 7/16-12	1 5/16-12	2.16	1.50	0.81	0.81

FF7504 37 DEGREE MALE JIC/FEMALE ORFS SWIVEL ADAPTER

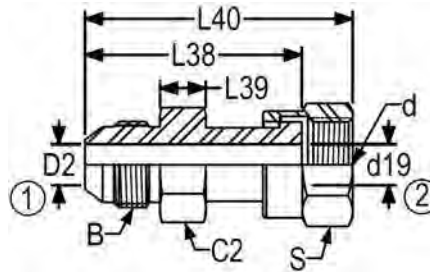

PART NO	TUBE OD	d UN/UNF-2B	B UN/UNF-2A	L40	L38	L39	C2	S	d19	D2
FF7504-04-04	1/4-1/4	9/16-18	7/16-20	1.50	0.95	0.34	0.56	0.40	0.17	0.17
FF7504-06-06	3/8-3/8	11/16-16	9/16-18	1.61	1.05	0.39	0.69	0.52	0.26	0.26
FF7504-08-08	1/2-1/2	13/16-16	3/4-16	1.90	1.24	0.40	0.88	0.64	0.36	0.36
FF7504-10-10	5/8-5/8	1-14	7/8-14	2.20	1.44	0.50	0.94	0.82	0.45	0.45
FF7504-12-12	3/4-3/4	1 3/16-12	1 1/16-12	2.50	1.64	0.61	1.13	0.98	0.55	0.55
FF7504-16-16	1-1	1 7/16-12	1 5/16-12	2.66	1.75	0.64	1.38	1.16	0.78	0.78
FF7504-20-20	1 1/4-1 1/4	1 11/16-12	1 5/8-12	2.80	1.84	0.69	1.69	1.46	1.02	1.02

O-Rings For SAE J-1453/2/3 Face Seal Ends

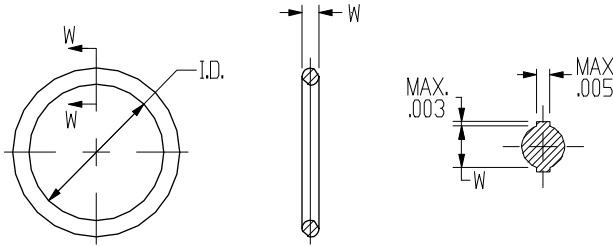

TUBE SIZE	STANDARD A-W PART #	ITEM #	OPTIONAL COMPOUND ITEM #			SAE AS568A REF. #	I.D.	W
	CH (BUNA-N) FF4000		HK (VITON) FF64001-	CH (HI-TEMP) ⁽¹⁾ FF64002-	CA (EPDM) FF64006-			
-04	FF4000-04	0100	0100	*	*	011	.301 ±.005	.070 ±.003
-06	FF4000-06	0200	0200	*	*	012	.364 ±.005	.070 ±.003
-08	FF4000-08	0300	0300	*	*	014	.489 ±.005	.070 ±.003
-10	FF4000-10	0400	0400	*	*	016	.614 ±.005	.070 ±.003
-12	FF4000-12	0500	0500	*	*	018	.739 ±.005	.070 ±.003
-16	FF4000-16	0600	0600	*	*	021	.926 ±.006	.070 ±.003
-20	FF4000-20	0700	0700	*	*	025	1.176 ±.006	.070 ±.003
-24	FF4000-24	0800	0800	*	*	029	1.489 ±.010	.070 ±.003
-32	FF4000-32	0900	0900	*	*	135	1.925 ±.017	.103 ±.003

SAE Type CH was SAE Type 1 Type CA was SAE Type 2 and Type HK was SAE Type 3.

Specification	SAE/ASTM Type CH	SAE/ASTM Type CA	SAE/ASTM Type HK
Usage	Nitrile Elastomer, 90 Durometer Hardness, for petroleum based fluids	EPDM Elastomer, 80 Durometer Hardness, for water based hydraulic or nonpetroleum based fluids	Fluorocarbon Elastomer, 90 Durometer Hardness, for petroleum or nonpetroleum based fluids
General Service	High pressure applications of pneumatics, water based hydraulic fluids, lubricating oils, hydraulic oils, and gasoline	High pressure applications of nonflammable hydraulic fluids of phosphate ester base type	High pressure, high temperature applications of pneumatic, water based hydraulic fluids, lubricating oils, hydraulic oils, and fuels
Temperature	-35°C to 125°C (-30°F to 250°F)	-40°C to 125°C (-40°F to 250°F)	-15°C to 275°C (5°F to 525°F)
Shore Hardness	90 pts ±5 pts	80 pts ±5 pts	90 pts ±5 pts
Elongation	100% min	150% min	100% min
Tensile	10 MPa min	10 MPa min	10 MPa min
Compound	Nitrile (Buna-N) to ASTM D 2000 or SAE J200 M4CH910B14E015E35Z1 Z1 = TR 10 temperature -21° C or lower. Alternate Low Temperature Product Test, 5 hours at -30° C, rings compressed 25% of ID, no cracks.	EPDM to ASTM D 2000 or SAE J200 M7CA810A25B35F17	M7HK910A1-11B38EF31E088Z1 Z1 = TR 10 temperature -15°C or lower (similar to MIL-R 83248 Type 1, Class 2)
Lubrication	When assembling Type CH O-Rings with O-Ring style fittings, the O-Ring shall be coated with the fluid used or petrolatum before assembly to ease installation.	When assembling Type CA O-Rings with O-Ring style fittings, lubricate the O-Ring with the fluid used in the system. Do not use a petroleum-based lubricant.	When assembling Type HK O-Rings with O-Ring style fittings, the O-Ring shall be coated with the fluid used or petrolatum before assembly to ease installation.

1. Type CH(HI-TEMP) Air-Way part #FF4002, 90 Durometer Nitrile Compound, temperature range -32°C to 135°C(-25°F to 275°F). Approved compounds National O-Ring Compound C67-90, Parker Seal Groove Compound N1059-90.

O-Rings For SAE J-1926/2/3 Stud Ends

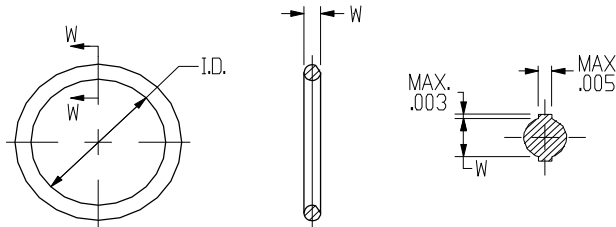

TUBE SIZE	STANDARD A-W PART #	ITEM #	OPTIONAL COMPOUND ITEM #			SAE AS568A REF. #	I.D.	W
	CH (BUNA-N) 4000		HK (VITON) 4001-	CH (HI-TEMP) ⁽¹⁾ 4002-	CA (EPDM) 4006-			
-02	4000-02	0001	*	*	*	902	.239 ±.005	.064 ±.003
-03	4000-03	0002	0002	*	*	903	.301 ±.005	.064 ±.003
-04	4000-04	0003	0003	0200	*	904	.351 ±.005	.072 ±.003
-05	4000-05	0004	0004	0300	*	905	.414 ±.005	.072 ±.003
-06	4000-06	0005	0005	0400	*	906	.468 ±.005	.078 ±.003
-08	4000-08	0006	0006	0500	*	908	.644 ±.009	.087 ±.003
-10	4000-10	0007	0007	0600	*	910	.755 ±.009	.097 ±.003
-12	4000-12	0008	0008	0700	*	912	.924 ±.009	.116 ±.004
-14	4000-14	0009	0009	0800	*	914	1.048 ±.010	.116 ±.004
-16	4000-16	0010	0010	0900	*	916	1.171 ±.010	.116 ±.004
-20	4000-20	0011	0011	1000	*	920	1.475 ±.014	.118 ±.004
-24	4000-24	0012	0012	1100	*	924	1.720 ±.014	.118 ±.004
-32	4000-32	0013	0013	*	*	932	2.337 ±.018	.118 ±.004

SAE Type CH was SAE Type 1 Type CA was SAE Type 2 and Type HK was SAE Type 3.

Specification	SAE/ASTM Type CH	SAE/ASTM Type CA	SAE/ASTM Type HK
Usage	Nitrile Elastomer, 90 Durometer Hardness, for petroleum based fluids	EPDM Elastomer, 80 Durometer Hardness, for water based hydraulic or nonpetroleum based fluids	Fluorocarbon Elastomer, 90 Durometer Hardness, for petroleum or nonpetroleum based fluids
General Service	High pressure applications of pneumatics, water based hydraulic fluids, lubricating oils, hydraulic oils, and gasoline	High pressure applications of nonflammable hydraulic fluids of phosphate ester base type	High pressure, high temperature applications of pneumatic, water based hydraulic fluids, lubricating oils, hydraulic oils, and fuels
Temperature	-35°C to 125°C (-30°F to 250°F)	-40°C to 125°C (-40°F to 250°F)	-15°C to 275°C (5°F to 525°F)
Shore Hardness	90 pts ±5 pts	80 pts ±5 pts	90 pts ±5 pts
Elongation	100% min	150% min	100% min
Tensile	10 MPa min	10 MPa min	10 MPa min
Compound	Nitrile (Buna-N) to ASTM D 2000 or SAE J200 M4CH910B14E015E35Z1 Z1 = TR 10 temperature -21° C or lower. Alternate Low Temperature Product Test, 5 hours at -30° C, rings compressed 25% of ID, no cracks.	EPDM to ASTM D 2000 or SAE J200 M7CA810A25B35F17	M7HK910A1-11B38EF31E088Z1 Z1 = TR 10 temperature -15°C or lower (similar to MIL-R 83248 Type 1, Class 2)
Lubrication	When assembling Type CH O-Rings with O-Ring style fittings, the O-Ring shall be coated with the fluid used or petrolatum before assembly to ease installation.	When assembling Type CA O-Rings with O-Ring style fittings, lubricate the O-Ring with the fluid used in the system. Do not use a petroleum-based lubricant.	When assembling Type HK O-Rings with O-Ring style fittings, the O-Ring shall be coated with the fluid used or petrolatum before assembly to ease installation.

1. Type CH(HI-TEMP) Air-Way part #4002, 90 Durometer Nitrile Compound, temperature range -32°C to 135°C(-25°F to 275°F). Approved compounds National O-Ring Compound C67-90, Parker Seal Groove Compound N1059-90.

ORFS Braze Rings

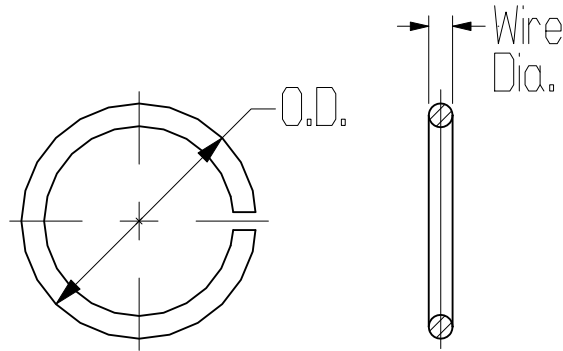

Inch Tube O.D.	Air-Way Part #	Ring O.D. (in)	Wire Dia. (in)
1/4	FF9000-4	.250	.046
5/16	FF9000-5	.312	.046
3/8	FF9000-6	.375	.046
1/2	FF9000-8	.500	.046
5/8	FF9000-10	.625	.060
3/4	FF9000-12	.750	.060
7/8	FF9000-14	.875	.060
1	FF9000-16	1.000	.060
1 1/4	FF9000-20	1.250	.060
1 1/2	FF9000-24	1.500	.060
2	FF9000-32	2.000	.060

Metric Tube O.D.	Air-Way Part #	Ring O.D. (mm)	Wire Dia. (mm)
6mm	MFF9000-6	6mm	1.168
8mm	MFF9000-8	8mm	1.168
10mm	MFF9000-10	10mm	1.168
12mm	MFF9000-12	12mm	1.168
16mm	MFF9000-16	16mm	1.168
20mm	MFF9000-20	20mm	1.524
22mm	MFF9000-22	22mm	1.524
25mm	MFF9000-25	25mm	1.524
30mm	MFF9000-30	30mm	1.524
38mm	MFF9000-38	38mm	1.524
50mm	MFF9000-50	50mm	1.524

Braze Alloy Specification	Silvaloy A 50N (BAg-24)
Industry Specifications Reference	AWS A5.8-BAg-24, ASME-BAg24, AMS-4788
Properties of Brazed Joints	Generally, the joint strength using Silvaloy A-50N will surpass the strengths of the base metals. Strength is a function of the base metals being joined, type of joint, design of joint, joint clearances and brazing procedures. The recommended maximum operating temperature for Silvaloy A-50N brazed assemblies is up to 700°F (370°C).
Usage	Silver brazing alloy for brazing carbon steels or 300 series stainless steels. This alloy contains no cadmium. The addition of nickel to the silver-copper zinc alloy imparts corrosion properties, which retards joint or interface corrosion of the brazed assembly.
Nominal Composition:	
Silver	50.0 +/- 1.0%
Copper	20.0 +/- 1.0%
Zinc	28.0 +/- 2.0%
Nickel	2.0 +/- 0.5%
Total Other Elements	0.15% Max.
Physical Constants:	
Solidus	1220°F (660°C)
Liquidus	1305°F (705°C)
Brazing Range	1310-1550°F (710-843°C)
Specific Gravity	8.98
Density (T.oz./cu.in.)	4.73
Electrical Conductivity (% IACS)	15.0
Electrical Resistivity (Microohm-cm)	11.75
Color	Light Yellow
Safety Information	It is essential that adequate ventilation be provided so that personnel will not inhale gasses and fumes while brazing. Equipment or facility should conform to the provisions of American National Standard (ANSI) Z49.1, "Safety in Welding and Cutting". For more complete information, refer to the Material Safety Data Sheet for Silvaloy A-50N.

Please see our additional product lines and on-line catalog at AIR-WAY.com



STAINLESS STEEL FITTINGS

include 37° flared tube fittings, Male and Female NPTF pipe, adjustable and O-Ring fittings, adapter unions and braze fittings for tubing.



INTERNATIONAL THREAD HYDRAULIC FITTINGS

are available in various configurations and sizes, including Metric, BSPP, SAEJ2244-1, ISO 6149-1 Ports and Metric JIC Conversion Fittings. We manufacture these fittings to the highest quality standards and stock them for immediate shipping.

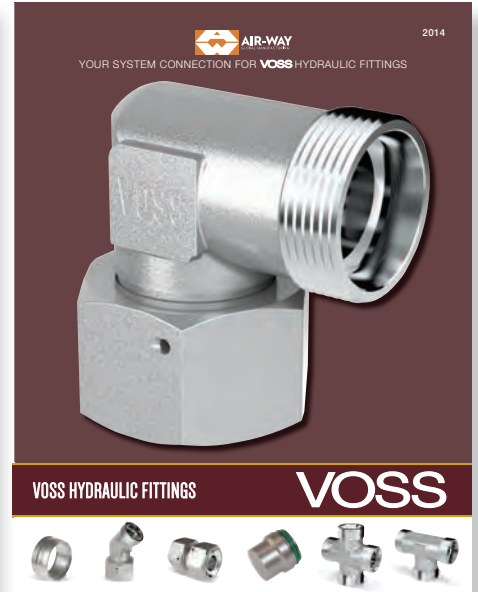

THE VOSS LINE

includes soft seal and flared couplings, flange couplings, cutting rings and a wide variety of accessories. These are offered in BSP, Metric, ISO, NPT and SAE threads, while conforming to DIN, ISO, SAE and ANSI/ASME standards. The ZAKO weldless flange product from VOSS offers an outstanding, cost effective solution for flange/tube welding applications.



GAUGE LINE CONNECTION PORT

Air-Way simplifies ordering of Gauge Line Connection Port fittings in all shapes and sizes. Use the photograph to select the port location, add the symbol as a suffix to the part number and show the combined symbol.

Example: 6801-8-8-NWO-2P2

6801-8-8-NWO	2	P2
90° Adjustable Elbow	Size	Position

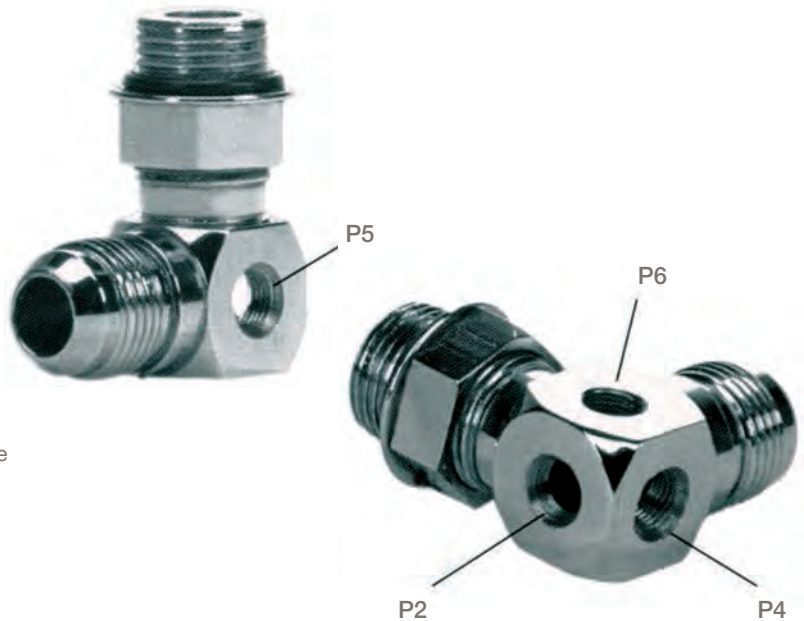

THE AIR-WAY ADVANTAGE

As a global manufacturer, AIR-WAY has the capabilities and equipment to get you what you need, when you need it. Our unique manufacturing and engineering capabilities allow us to fulfill your need for custom fittings and adapters that include: Special Configurations, Cost Reduction and System Simplification. Since 1950, we have served some of the largest and most recognized OEMs in the world.

Our team is dedicated to delivering high quality hydraulic fittings and adapters when and where you want them, all at competitive prices.

Ask about our **AIR-WAY Direct™** program, which means your order ships the same day it's received. You can take advantage of several benefits including special packaging, shipping and service programs.

Air-Way is an ISO 9001:2008 Certified company.

AIR-WAY Manufacturing | *Adapt to Anything*

ORDER INFORMATION

Sizes of the fittings are indicated by the dash numbers as relating to sixteenth's of an inch measured from the Outside Diameter of the tube size used. For example; 1/2" O.D. (8/16) or - 8. Male or Female pipe sizes are similar in that 1/2" pipe thread is also (8/16) or - 8.

Standard items can be ordered using the appropriate chart and dash numbers. For example: 2501-8-6 is a 1/2" tube end with 3/4-16 straight thread on that end, and 3/8" pipe thread on the other end. 2501-8-12 is a 1/2" tube end with 3/4-16 straight thread on that end, and 3/4" pipe thread on the other end.

Adjustable and O-Ring fittings may be purchased in various stages of assembly. For example: 6801-8-8-NWO would be assembled complete with "N" Nut, "W" Washer, and "O" O-Ring. 6801-8-8-NW would be assembled with "N" Nut, and "W" Washer only.

Many items are available in brazed or forged style construction. If a forged style is preferred, simply add a "G" prefix to the item number or the suffix "FG" after the number.

Special items and configurations are available to order using customer specifications. Pricing and availability of these items can be furnished on request.



AIR-WAY MANUFACTURING COMPANY | 586 N. MAIN STREET | OLIVET, MI 49076

p 800-253-1036 | p 269-749-2161 | f 269-749-2046 | e sales@AIR-WAY.com | w AIR-WAY.com

AIR-WAY GLOBAL MANUFACTURING | *ADAPT TO ANYTHING*